

21 Metre 4x4 Hybrid Knuckle Boom

Features

- Winner of the International Powered Access Federation's 'IAPA Product of the Year 2018' award, the HeightRider 21 4x4 (HR21 4x4) self-propelled cherry picker will lift 2 persons and their tools to a working height of 20.8m or a working outreach of 13m.
- Proportional controls deliver smooth, measured operation while 160° cage rotation and a 150° fly-boom allow precise positioning anywhere in its vast working envelope.
- Weighing just 6,640kg, the HR21 4x4 combines innovative weight and space saving design with an excellent turning circle to deliver outstanding manoeuvrability on-site and lower transportation costs.
- The HR21 4x4's 1.8m wide ToughCage (steel cage option available) offers more space for materials and tools and the tough, impact-resistant composite base and larger cross-section steel rails of the ToughCage also give additional strength and durability, while providing additional operator protection.



Deisel & Electric

- Available with two power options, Diesel-only or Hybrid power:
- The **Diesel** option incorporates a versatile and efficient TIER IV compliant engine to deliver maximum traction and gradeability, making it ideal for rough or uneven ground.
- The **Hybrid** option incorporates a smaller, power-optimised TIER IV compliant engine supported by the machine's battery pack for when extra power is needed. This maintains power and performance while reducing fuel consumption for maximum efficiency. The Innovative 'Diesel Re-Gen' feature also recharges the batteries without a mains power source, giving a 'fast-charge' whenever the machine is idle and the engine running. In addition, an electric-only mode allows zero-emission operation, making it ideal for indoor use, or for quiet, clean operation.



Specifications

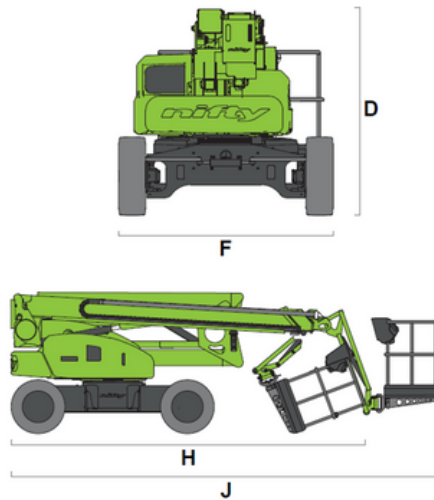
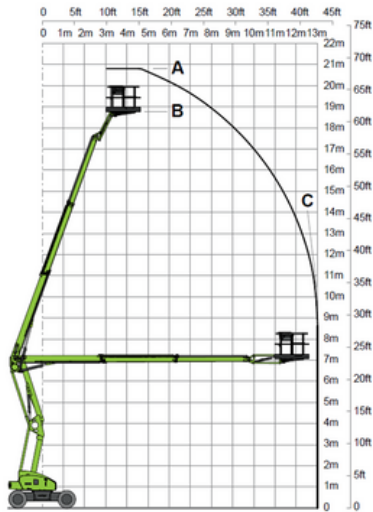

Working Height
20.8m (68ft 6in)

**Unrestricted Working
Outreach at 250kg**
13m (42ft 8in)

45% Gradeability
4WD for rough terrainGVW Only 6,640kg
Lightest in its class

ToughCage with SiOPS®
Multi-award winning operator protection

Superb Manoeuvrability
3.89m outside turning radius

Suspension System
Improving traction & comfort

Swing-Out Engine Tray
Quick & easy to service

Platform Rotation & Fly-Boom
Improved access to
applications

**Maintenance-Free Batteries as
Standard**
Reducing maintenance
downtime

**Full Battery Monitoring &
Protection**
Increasing battery life and
lowering costs

**Second Generation Hybrid
Power Available**
Environmentally conscious
and more fuel-efficient
power

- (A) 20.8m
68ft 6in
- (B) 18.8m
62ft
- (C) 13m
42ft 8in
- 250kg
550lbs
- 1.8m x 0.8m
5ft 11in x 2ft 8in
- 150°
- 160°
- (D) 2.18m
7ft 2in
- (F) 2.27m
7ft 5in
- (H) 5.47m
17ft 11in
- (J) 6.62m
22ft
- 6km/h
3.7mph
- 3.89m
12ft 9in
- 45%
24°
- 6640kg
14640lbs

access-HIRE

Reach New Heights!

Nelson Office:

9 Vivian Place
Tahunanui
Nelson 7011

Marlborough Office:

109b Redwood Street
Blenheim 7201

Ph: 03 546 4111 | Free: 0508 546 411

E: admin@access-hire.co.nz

Servicing the Top of the South Island Region

View More Online

WWW.SAFEHIRE.CO.NZ