

M a n u f a c t u r e r s i n c e 1 9 4 8

General CATALOGUE

FOLDING
SHEARING
ROLL FORMING
BEADING
SWAGING
ARCH-FOLDING
DECOILERS
CUTTING UNITS

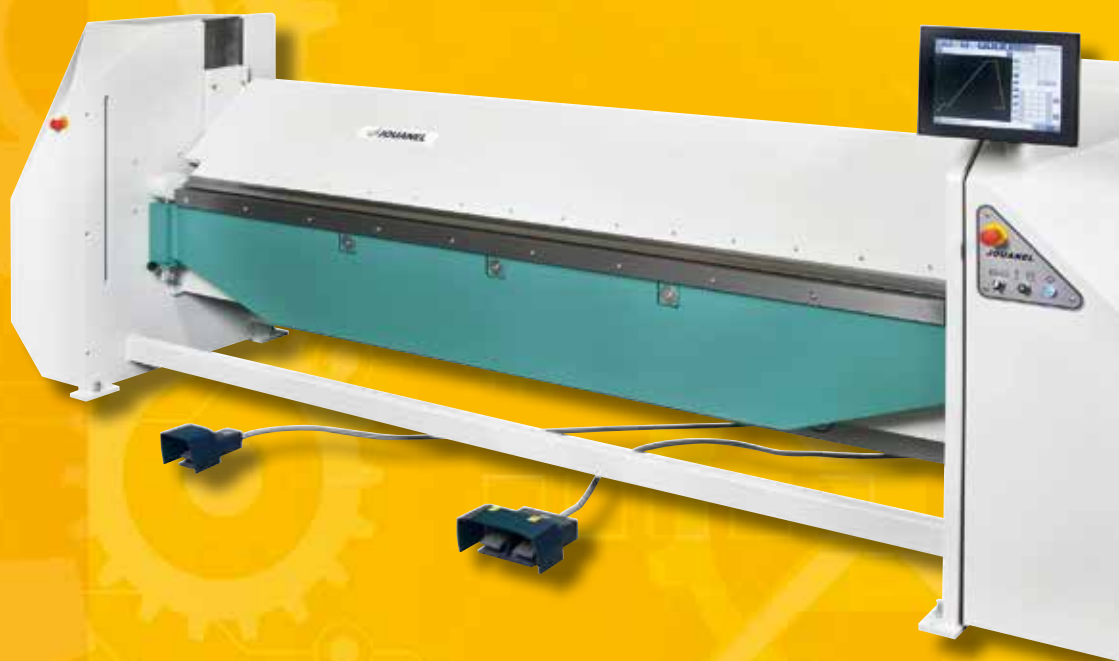

**FOLDING
SHEARING
ROLL FORMING
BEADING
SWAGING
ARCH-FOLDING
DECOILERS
CUTTING UNITS**



Export sales organization

www.jouanel.com

Follow us!



Channel "JOUANEL Industrie"

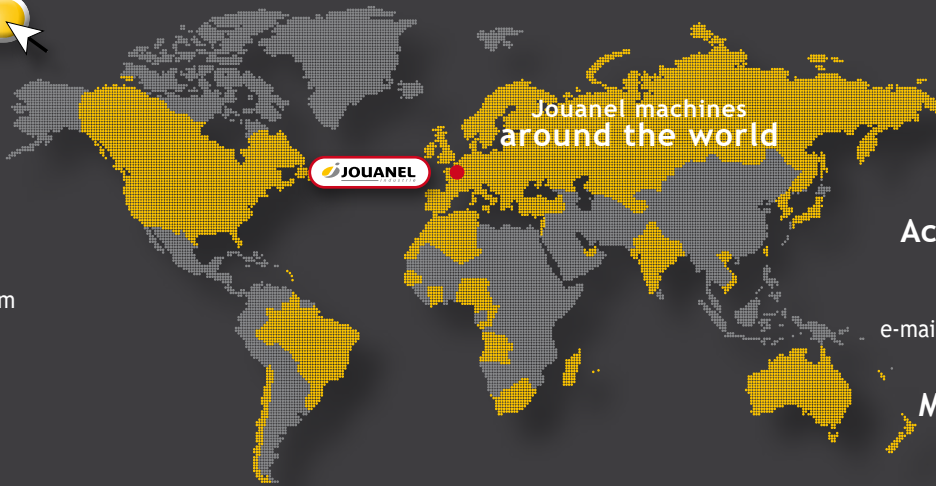

General Manager

Emmanuel HALLÉ
e-mail: e.halle@jouanel.com

Accounting Manager

Agnès FOUCTEAU
Phone: +33 247 654 632
e-mail: a.foucteau@jouanel.com

Sales Manager

Guylaine JUSTE
Phone: +33 247 654 561
Mobile: +33 685 412 175
e-mail: g.juste@jouanel.com

Marketing Manager

Marc RICHARD
Phone: +33 247 654 067
Mobile: +33 685 411 280
e-mail: marketing@jouanel.com

A team at your service

JOUANEL Industrie Headquarters

30 rue des Saulniers
37800 Sainte-Maure-de-Touraine • FRANCE
Phone: +33 247 654 067 • Fax: +33 247 655 161
e-mail: export@jouanel.com

Export Sales Representative Western Europe

Arnaud MELEUX
Mobile: +33 608 489 850
e-mail: com-export@jouanel.com

Export Assistant

Lou BROCHARD
Phone: +33 247 651 651
e-mail: export@jouanel.com

Export Sales Representative Eastern and Central Europe

Kamil JURGIELEWICZ
Phone: +33 247 349 344
Mobile: +48 668 471 327
e-mail: k.jurgielewicz@jouanel.com

HVAC

Technical Sales Representative

Sébastien PETIT
Phone: +33 247 651 648
Mobile: +33 685 412 180
e-mail: s.petit@jouanel.com

Technical Support

Yoann GOURBIER
Phone: +33 247 651 649
e-mail: contactsat@jouanel.com

Overseas France

- New Caledonia
- Reunion
- French Guiana
- Guadeloupe
- Tahiti

Europe

- France
- United Kingdom
- Germany
- Austria
- Slovenia
- Benelux
- Switzerland
- Italy
- Greece
- Spain
- Portugal
- Poland
- Baltic states
- Scandinavia
- Romania
- Czechia
- Slovakia

Africa

- Algeria
- Morocco
- Tunisia
- Congo
- Mali
- Ivory Coast
- Cameroon
- Angola

Asia / Oceania

- Russia
- Kazakhstan
- Uzbekistan
- Tajikistan
- Vietnam
- India
- Taiwan
- Australia
- New Zealand























North & South America

- USA
- Canada
- Chili
- Brazil

Middle East

- Turkey
- Lebanon
- Emirates
- Israel

Contents

 Folding machines	P. 4 to 29
 Shearing machines	P. 30 to 43
 Beading machines	P. 44 to 45
 Swaging machines	P. 46 to 47
 Roll forming machines	P. 48 to 56
 Electric seamers	P. 57 to 58
 Electric slitting machine	P. 59
 Electric arch-folding machine	P. 59
 Decoilers and roller table	P. 60 to 61
 Asymmetrical roll-bending machines	P. 62 to 64
 Cutting units	P. 65 to 69
 Miscellaneous equipment	
 Flat bar bending machine	P. 72
 Hand corner notcher	P. 72
 Shears for metal sheet	P. 73
 Light manual roofing machines (portable)	
 Manual arch-folding machine for beads	P. 73
 Hand edge rollers and accessories	P. 74 to 76
 « Parisian » type folder	P. 77
 Pipe flaring tool	P. 78
 Slate cutter	P. 79
 See index on the back	

Manual building site folding machines - PCL

Machine sizes available: 1m and 1,20 m

Manual building site folding machines: PCL1020A and PCL1270A

Ref. PCL1020A: High capacity, low weight!



DEMONSTRATION VIDEO
available on YouTube® / Channel
"Jouanel Industrie"

Standard equipment

- Narrow folding beam: 15 mm
- Max folding angle: 143°
- Foldable and removable legs **1**
- Clamping beam lock with an eccentric

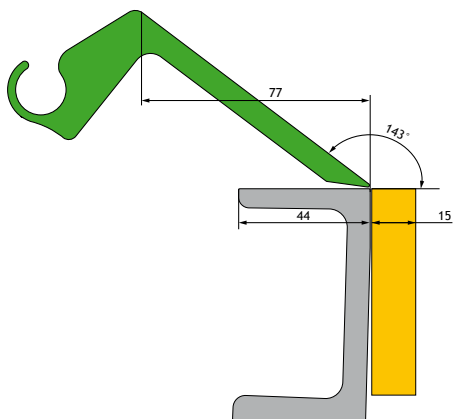

Ref. PCL1020A and PCL1270A



Ref. PCL1020A shown
with options



1

Ref. PCL1020A
folded
with option

Options

- Beading accessory with 13 mm Ø rod capacity zinc 0,65 mm Ref. **BAL1020MAN** **2** only for Ref. PCL1020A
- Beading accessory equipped with gear train **3** 14, 16 or 18 mm Ø (Ø to be specified upon order)
Ref. ABH14-1020, ABH16-1020, ABH18-1020 for Ref. PCL1020A
Ref. ABH14-1300, ABH16-1300, ABH18-1300 for Ref. PCL1270A
- Guide rail **4** for roller shear:
Ref. RCL1020B for Ref. PCL1020A
Ref. RCL1270B for Ref. PCL1270A
- Roller shear Ref. **CCM** **5** (guide rail required)
 - Handy, robust aluminum body
 - Tempered steel rollers for a longer lifespan
 - Guide rail and 2 grip handles ensure an accurate cut
 - Capacity zinc 0,8 mm

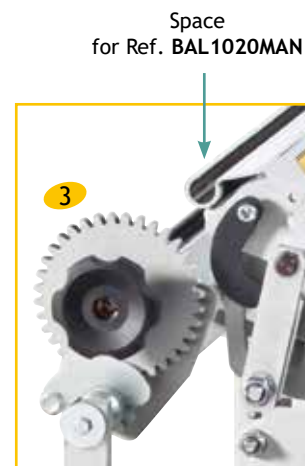
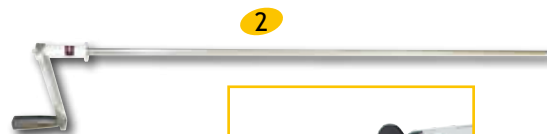

Features	PCL1020A	PCL1270A
Useful folding length (mm)	1 020	1270
Capacity zinc (mm)	0,8	0,7
Capacity S235JR steel (mm)	0,6	0,55
Clamping beam opening (mm)	60	60
Cutting device option	yes	yes
Beading accessory option	yes	yes
Dimensions (mm) - legs excluded	1 200 x 300 x 150	1 450 x 300 x 170
Net weight (kg) - legs included	39	53

Minimum fold width = 15 times the thickness

Capacity of beading accessory with gear train* (mm)	ABH	
	1020A	1270A
Ø 14	0,8	0,7
Ø 16	1	0,8
Ø 18	1	1

* Capacity zinc or copper (in mm)

Manual building site folding machine - PCA

Folding machine PCA available in 2m

Manual building site folding machine: PCA2040

It's portable!

Standard equipment

- Folding beam with narrow 15-mm interchangeable tool in tempered steel
- Interchangeable 158° clamping beam tool in tempered steel
- Clamping beam operating lever on the right side of the machine **1**
- Clamping beam lock with an eccentric
- Angle scale **2**
- Folding beam crowning adjustment **3**
- Handle to lower or raise the machine **4**
- Two 200-mm Ø wheels for easy handling

Note: To flatten folds on this model, using the OFP-180 hem closing tool is required (see additional equipment)



PCA2040 model shown with options

YouTube

DEMONSTRATION VIDEO available on YouTube® / Channel "Jouanel Industrie"



Model PCA2040 folded, shown without options

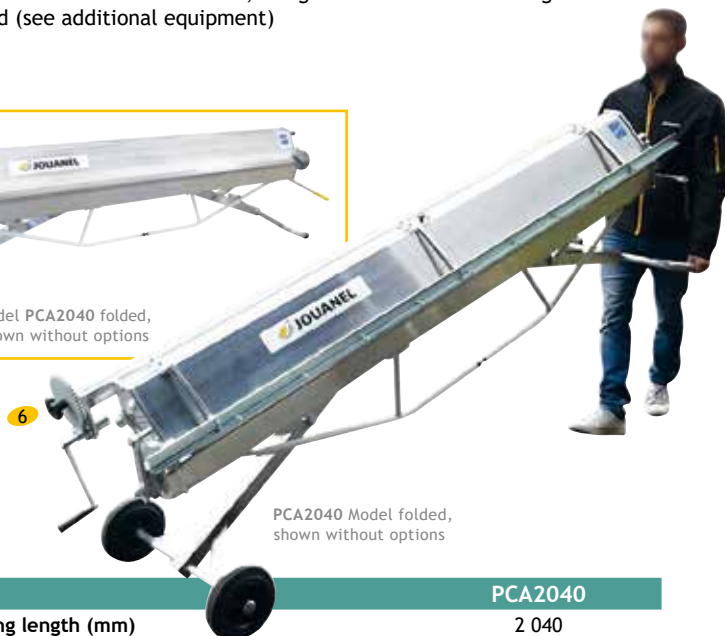

PCA2040 Model folded, shown without options

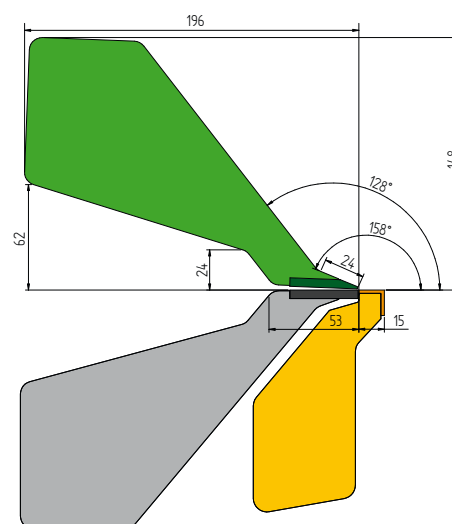

Features	PCA2040
Useful folding length (mm)	2 040
Capacity zinc / 1050-H44 aluminum (mm)*	0,8
Capacity steel (mm)*	0,63
Clamping beam tool angle	158°
Clamping beam opening (mm)	60
Dimensions (mm)	2 330 x 650 x 1070
Dimensions when folded (mm)	2 330 x 650 x 640
Table height (folding machine completely unfolded) (mm)	900
Net weight (without accessories) (kg)	80

min. fold width = 15 mm

*not for flattening folds



Options (see details P15 to 17)

- Sliding back gauge type X - from 55 to 510 mm:
2 adjustable gauge arms Ref. PCAB2040
1 adjustable gauge arm Ref. PCABS2
- Aluminum beading accessory with gear train for 14 or 16mm Ø rods Ref. ABA2040 **5**
- Guide rail for roller shear Ref. RCA2040
- Roller shear Ref. CCMA **6**
- 180° Hem closing tool Ref. OFP-180

In a workshop or on a building site, it can do everything!

The PCX machine structure is very sturdy and provides excellent folding quality on a building site or in a workshop

Machine sizes available: 1m, 2m, 2,50 m and 3m

Manual building site or workshop folding machine: PCX1020

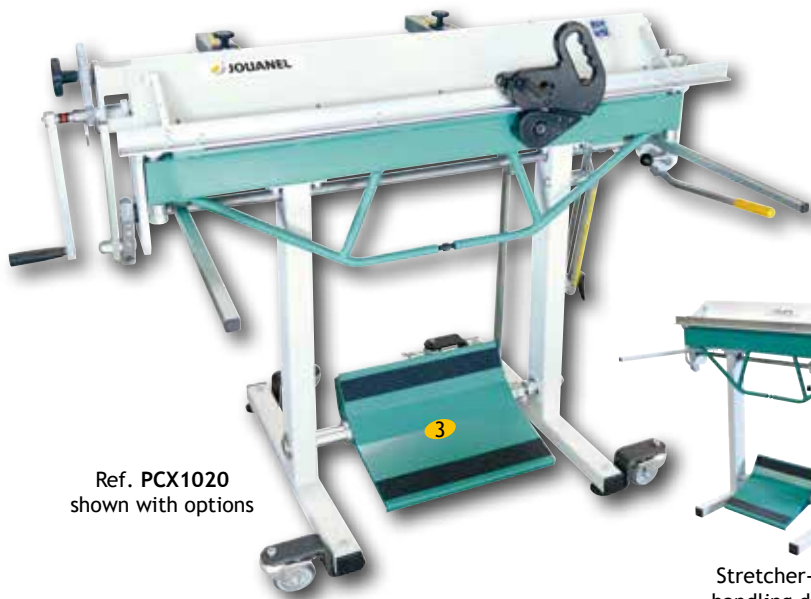

Ref. PCX1020 shown with options

Stretcher-type handling device

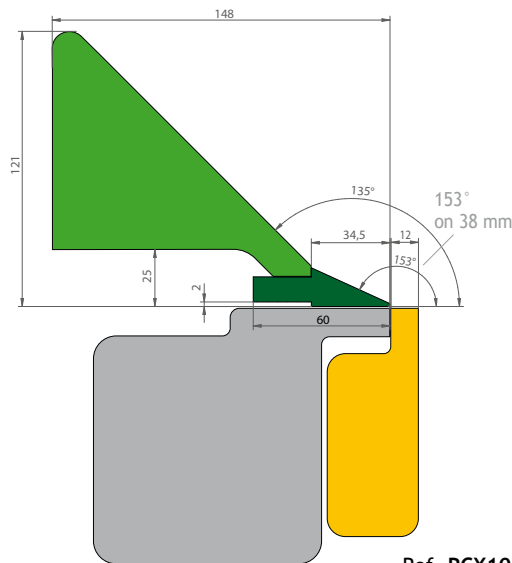

Ref. PCX1020

Standard equipment

- Narrow folding beam: 12 mm
- Interchangeable clamping beam tool: 27°
- Cylinder to easily open the clamping beam
- Quick adjustment of the clamping beam opening
- Quick adjustment of the clamping beam with an eccentric
- Adjustable table, clamping and folding beams for higher accuracy
- Graduated angle gauge for series folding
- Folding beam crowning adjustment
- Removable legs
- Stretcher-type handling device

Manual building site or workshop folding machines: PCX2040A and PCX2540A

Standard equipment

- Narrow folding beam: 15 mm
- Clamping beam tool: 27°
- Cylinder to easily open the clamping beam
- Quick adjustment of the clamping beam opening
- Quick adjustment of the clamping beam by eccentric
- Adjustable table, clamping and folding beams for higher accuracy
- Graduated angle gauge for series folding
- Folding beam crowning adjustment
- Removable legs



Ref. PCX2040A shown with options

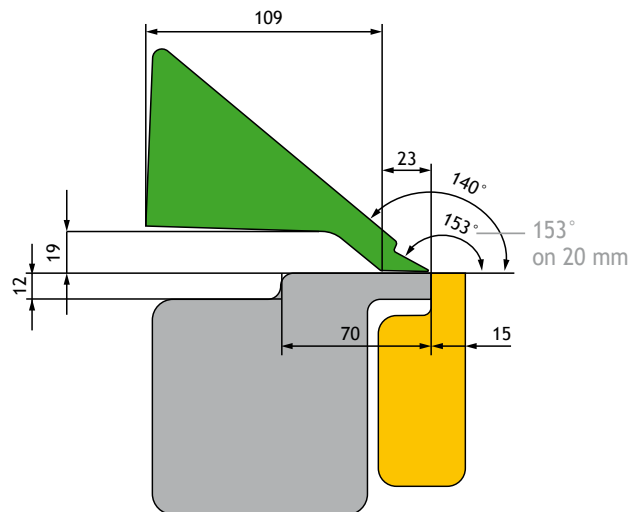

Ref. PCX2040A and PCX2540A

● Manual building site or workshop folding machine: PCX3080A

Standard equipment

- Narrow folding beam: 15 mm
- Interchangeable clamping beam tool: 27°
- Cylinder to easily open the clamping beam
- Quick adjustment of the clamping beam opening
- Quick adjustment of the clamping beam with an eccentric
- Adjustable table, clamping and folding beams for higher accuracy
- Graduated angle gauge for series folding
- Folding beam crowning adjustment
- Removable legs



Ref. PCX3080A
shown with options

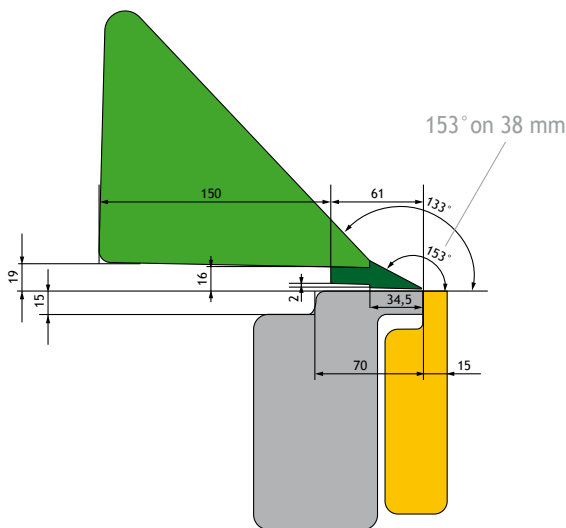

Graduated angle gauge



Quick adjustment
of the clamping beam opening

Features	PCX1020	PCX2040A	PCX2540A	PCX3080A
Useful folding length (mm)	1 020	2 040	2 540	3 080
Capacity Stainless steel / 1050-H44 aluminum (mm)	0,7 / 1,5	0,6 / 1,0	0,6 / 1,0	0,6 / 1,0
Capacity zinc / S235JR steel (mm)	1,5 / 1,2	1,0 / 0,7	1,0 / 0,7	1,0 / 0,7
Clamping beam opening (mm)	70	70	70	80
Dimensions (mm)	1266 x 1022 x 660	2 260 x 1 040 x 600	3 100 x 1 060 x 600	3 650 x 1 060 x 650
Gross weight (kg)	104	160	240	350

Minimum fold width = 15 times the thickness

● Options

- Set of 4 wheels for folding machines PCX1020, PCX2040A and PCX2540A: Ref. PCXR2040 ①
Set of 4 wheels for folding machine PCX3080A: PCXR3040 ②
- Clamping foot pedal for folding machine PCX1020: Ref. PCXP1020 ③
Clamping foot pedal for folding machines PCX2040A and PCX2540A: Ref. PCXP2040A ④
Clamping foot pedal for folding machine PCX3080A: PCXP3040 ⑤
- Other options: see pages 15 to 17



Manual workshop folding machines - PZX

Multipurpose, accurate and high-performance, the PZX folding machine is especially suitable to process small batches of zinc or steel parts, for roofing or cladding construction work.

Thanks to the sturdiness of its design, its excellent folding quality and its comfortable use on a daily basis, the PZX is truly ideal in terms of workshop equipment.

This machine is the first manual workshop folding machine developed in collaboration with an ergonomist: the central release of the folding beam offers optimal operator position and minimizes the effort required for sheet metal bending. Its numerous adjustment possibilities and additional equipment maximize productivity and flexibility, making it the ultimate workshop folding machine!

Machine sizes available: 2 m and 2,5 m

Manual workshop folding machines: PZX2040 and PZX2540

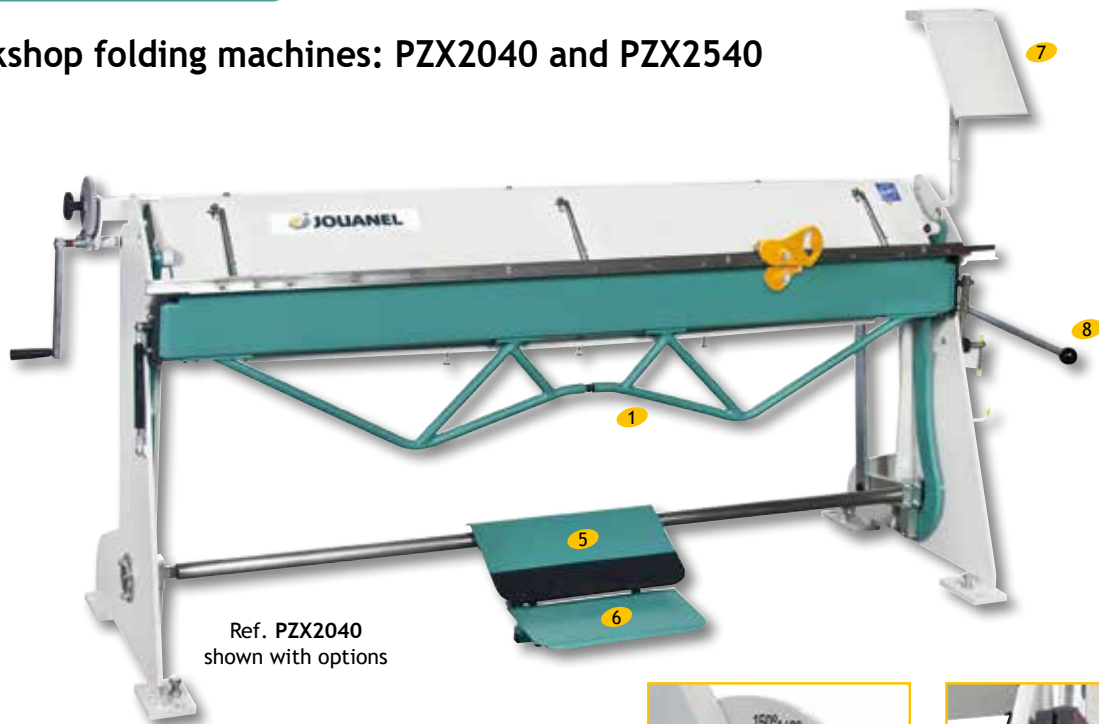

Ref. PZX2040
shown with options

Standard equipment

- Ergonomic folding beam with narrow 12 mm-tool to make close reverse bends (ex. flashing) **1**
- Interchangeable clamping beam tool: 27° **2**
- Cylinder assists bending and ensures work reliability and rapidity
- Angle scale **3**
- Graduated angle gauge enabling an accurate stop of the folding beam for series folding **4**
- Clamping **5** / opening foot pedal **6**
- Console and tool support **7** (left-hand or right-hand assembly)
- Operating lever of the clamping beam on the right side of the machine **8**



3 Angle scale



4 Graduated angle gauge

Features	PZX2040	PZX2540
Useful folding length (mm)	2 040	2 540
Capacity zinc / S235JR steel (mm)	1,2 / 1,0	1,2 / 1,0
Clamping beam opening (mm)	100	100
Dimensions (mm)	2 420 x 690 x 1 520	2 920 x 690 x 1 520
Table height (mm)	920	920
Gross weight (kg)	470	580

Minimum fold width = 15 times the thickness

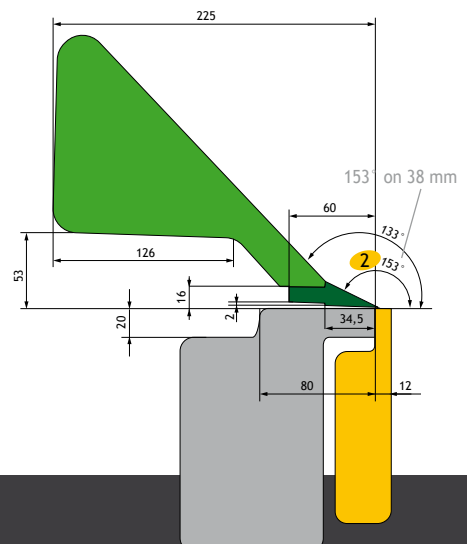

Options

Other options: see pages 15 to 17

As with the PZX machines, the PVX manual folding machine is also one of the models designed with an ergonomic folding beam, suitable for daily work in workshops. The central release of the folding beam allows the operator an optimal position which minimizes the effort required for repetitive folding.

The sleek and robust engineering design of the PVX machine provides high rigidity for excellent folding quality as well as high accuracy, even with thicker sheets. Its numerous adjustment options and additional equipment provide even more productivity and flexibility of use.

Machine sizes available: 2 m and 3 m

Exist in manual version, semi-electric and segmented clamping beam

Manual workshop folding machines: PVX2040 and PVX3080

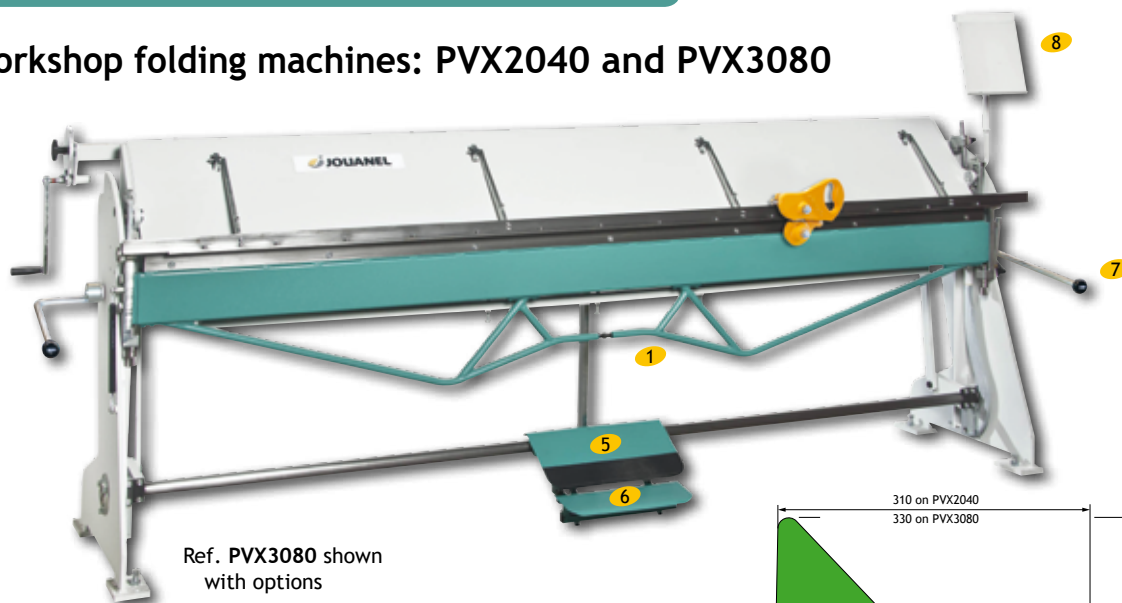

Ref. PVX3080 shown with options

Standard equipment

- Ergonomic folding beam with narrow 15 mm-tool for making close reverse bends **1**
- Interchangeable clamping beam tool: 27° **2**
- Cylinder assists bending and ensures work reliability and rapidity, rotation of folding beam on needle roller bearings
- Angle scale **3**
- Graduated angle gauge **4**
- Operation of the upper beam by clamping **5** / opening foot pedal **6** and with a lever on both sides of the machine **7**
- Vertical adjustment of the folding beam is easy using the graduated wheel, allowing the radius setting and facilitating reverse bends
- Console and tool support **8**
- Folding beam pins mounted on roller bearings

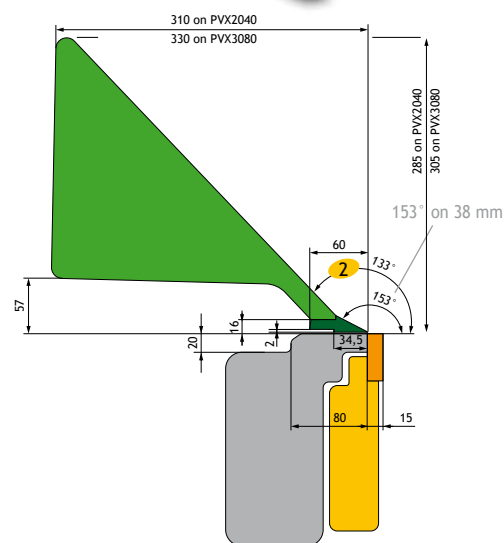

Features	PVX2040	PVX3080
Useful folding length (mm)	2040	3080
Capacity zinc / S235JR steel (mm)*	1,5/1,2	1,2/1,0
Clamping beam opening (mm)	110	110
Dimensions (mm)	2 738 x 795 x 1 215	3 775 x 795 x 1 215
Gross weight (kg)	620	850

* Capacity with standard tool of 15 mm



3 Angle scale



4 Graduated angle gauge

Options

- Additional narrow 12 mm-folding beam tool Ref. PVX-REG12-2040 / PVX-REG12-3080 (capacity - 30%)
- Additional wide 20 mm-folding beam tool Ref. PVX-REG20-2040 / PVX-REG20-3080 (capacity + 20%)
- Other options: see pages 15 to 17

Manual workshop folding machines with segmented clamping beam - PVXT



Manual workshop folding machines with segmented clamping beam: PVX2040T and PVX3080T

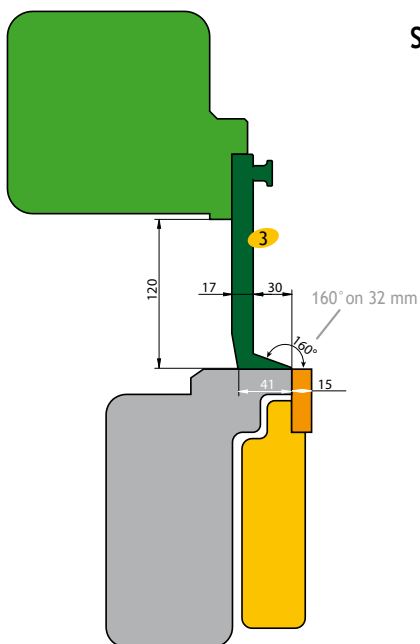

Standard equipment

- Quick disassembly of the segments with pull-device **1**
- Clamping beam with engraved segments (width of the segments)
- Left **2** and right corner segments (30 mm)
- Interchangeable clamping beam segmented tool: 20° **3**
- Automatic clamping beam lock
- Ergonomic folding beam **4** with narrow 15mm- tool for making close reverse bends
- Cylinder assists bending and ensures work reliability and rapidity, rotation of folding beam on needle roller bearings
- Graduated angle gauge **5**
- Angle scale **6**
- Operation of the upper beam by clamping **7** / opening foot pedal **8** and with a lever on both sides of the machine **9**
- Vertical adjustment of the folding beam is easy using the graduated wheel, allowing the radius setting and facilitating reverse bends
- Console and tool support **10**
- Support for segments **11**
- Folding beam pins mounted on roller bearings

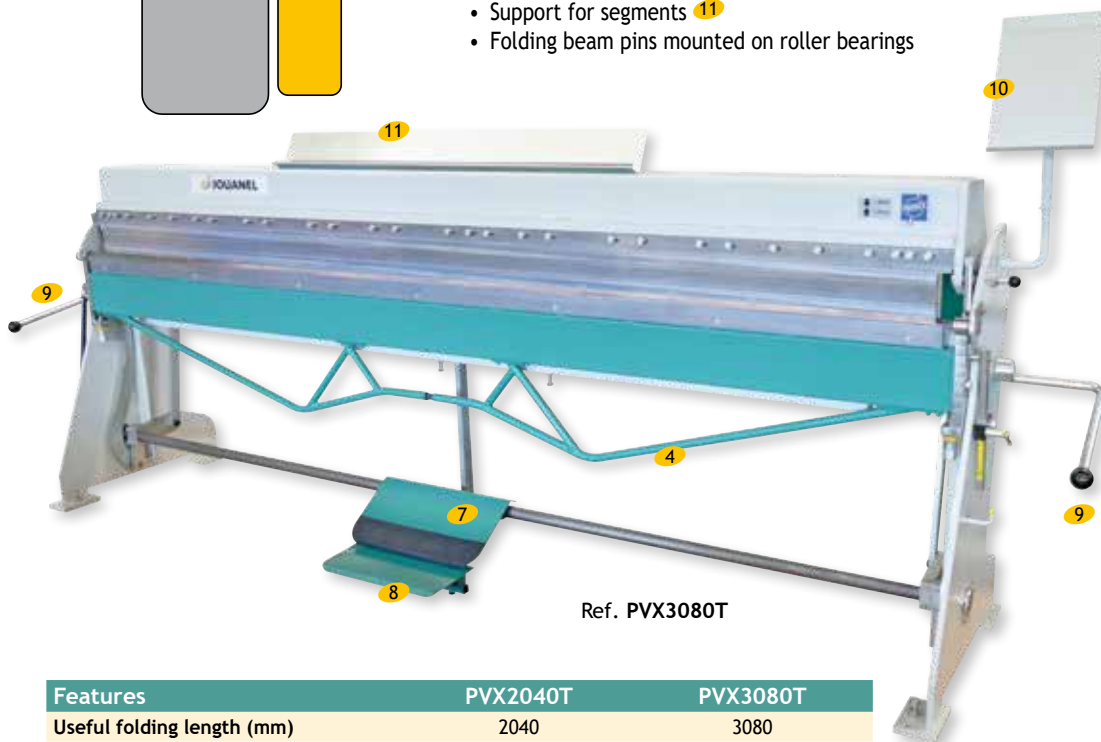
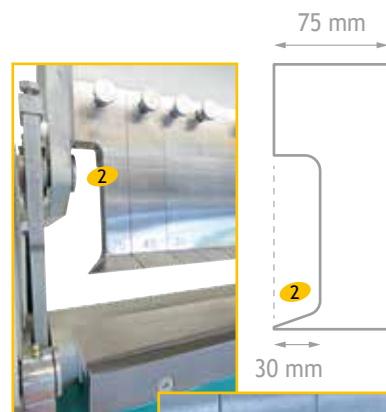

Ref. PVX3080T



1 Quick disassembly of the segments with pull-device

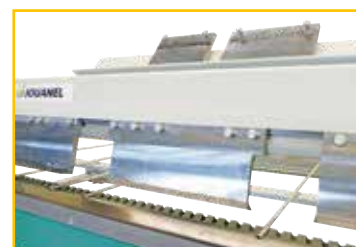

5 Graduated angle gauge

6 Angle scale

Features	PVX2040T	PVX3080T
Useful folding length (mm)	2040	3080
Capacity zinc / S235JR steel (mm)*	1,2 / 1	1 / 0,8
Clamping beam tool angle	160°	160°
Clamping beam opening (mm)	95	95
Useful segment height (mm)	120	120
Dimensions (mm)	2710 L x 800 l x 1400 H	3750 L x 800 l x 1400 H
Gross weight (kg)	670	915
Useful segment height (mm)	25, 30, 35, 50, 75, 75, 100, 150, 200, 200, 200, 300, 300, 300	25, 30, 35, 40, 50, 75, 75, 100, 100, 150, 150, 200, 200, 250, 250, 250, 300, 300, 300

* Capacity with standard 15 mm-tool

Options

- Additional narrow 12 mm-folding beam tool Ref. PVX-REG12-2040 / PVX-REG12-3080 (capacity - 30%)
- Additional wide 20 mm-folding beam tool Ref. PVX-REG20-2040 / PVX-REG20-3080 (capacity + 20%)
- Other options: see pages 15 to 17

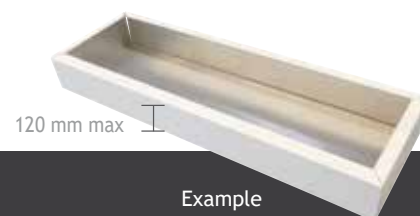

● Semi-electric workshop folding machines: PVX2040PE and PVX3080PE

PVXPE folding machines with electric clamping beams have the same folding capacities as the PVX manual machines. The electric clamping beam lock gives the operator more comfort, ergonomics and faster working speed.

- The clamping beam releases automatically upon fold completion, no need for pedal activation
- Moveable foot operated control, more convenient for clamping large-sized sheets
- Flattening folds is easy and effortless with this motorized clamping beam
- Clamping beam height can be adjusted easily
- Security device prevents crushing

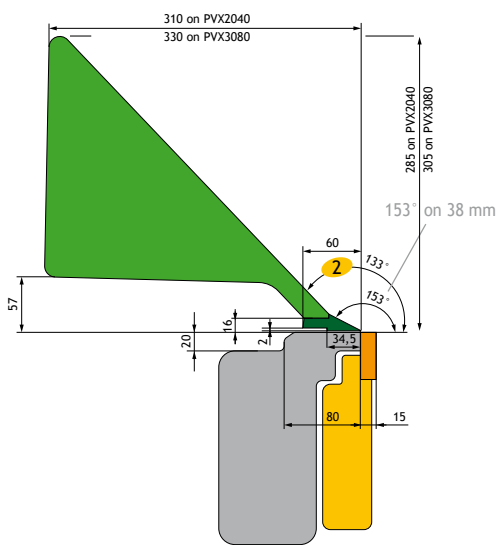

Ref. PVX3080PE

Standard equipment

- Ergonomic folding beam **1** with narrow 15 mm-tool for making close reverse bends
- Interchangeable clamping beam tool: 20° **2**
- Cylinder assists bending, ensures work reliability and rapidity, rotation of folding beam on needle roller bearings
- Graduated angle gauge **3**
- Angle scale **4**
- Clamping operated by foot pedal **5**
- Automatic clamping beam release once folding is complete
- Manual release operated by foot pedal **6**
- Vertical adjustment of the folding beam is easy using the graduated wheel, allowing the radius setting and facilitating reverse bends
- Console and tool support **7**
- Folding beam pins mounted on roller bearings



3 Graduated angle gauge



4 Angle scale

● Options

- Additional narrow 12 mm-folding beam tool
Ref. PVX-REG12-2040 and PVX-REG12-3080 (capacity - 30%)
- Additional wide 20 mm-folding beam tool
Ref. PVX-REG20-2040 and PVX-REG20-3080 (capacity + 20%)
- Other options: see pages 15 to 17

Features	PVX2040PE	PVX3080PE
Useful folding length (mm)	2040	3080
Capacity zinc / S235JR steel (mm)*	1,5/1,2	1,2/1,0
Clamping beam opening (mm)	110	110
Power supply (V)**	220 V single-phase	220 V single-phase
Power (kW)	0,25	0,25
Dimensions (mm)	2 600 x 795 x 1 215	3 600 x 795 x 1 215
Gross weight (kg)	706	936

* Capacity with standard 15 mm-tool

** Voltage choice to be specified upon order

Semi-electric folding machines with segmented clamping beam - PVXTPE



• Semi-electric folding machines with segmented clamping beam: PVX2040TPE and PVX3080TPE

PVXTPE folding machines with electric clamping beams have the same folding capacities as the PVXT manual machines. The electric clamping beam lock gives the operator more comfort, ergonomics and faster working speed.

- The clamping beam releases automatically upon fold completion, no need for pedal activation
- Moveable foot operated control, more convenient for clamping large-sized sheets
- Flattening folds is easy and effortless with this motorized clamping beam
- Clamping beam height can be adjusted easily
- Security device prevents crushing

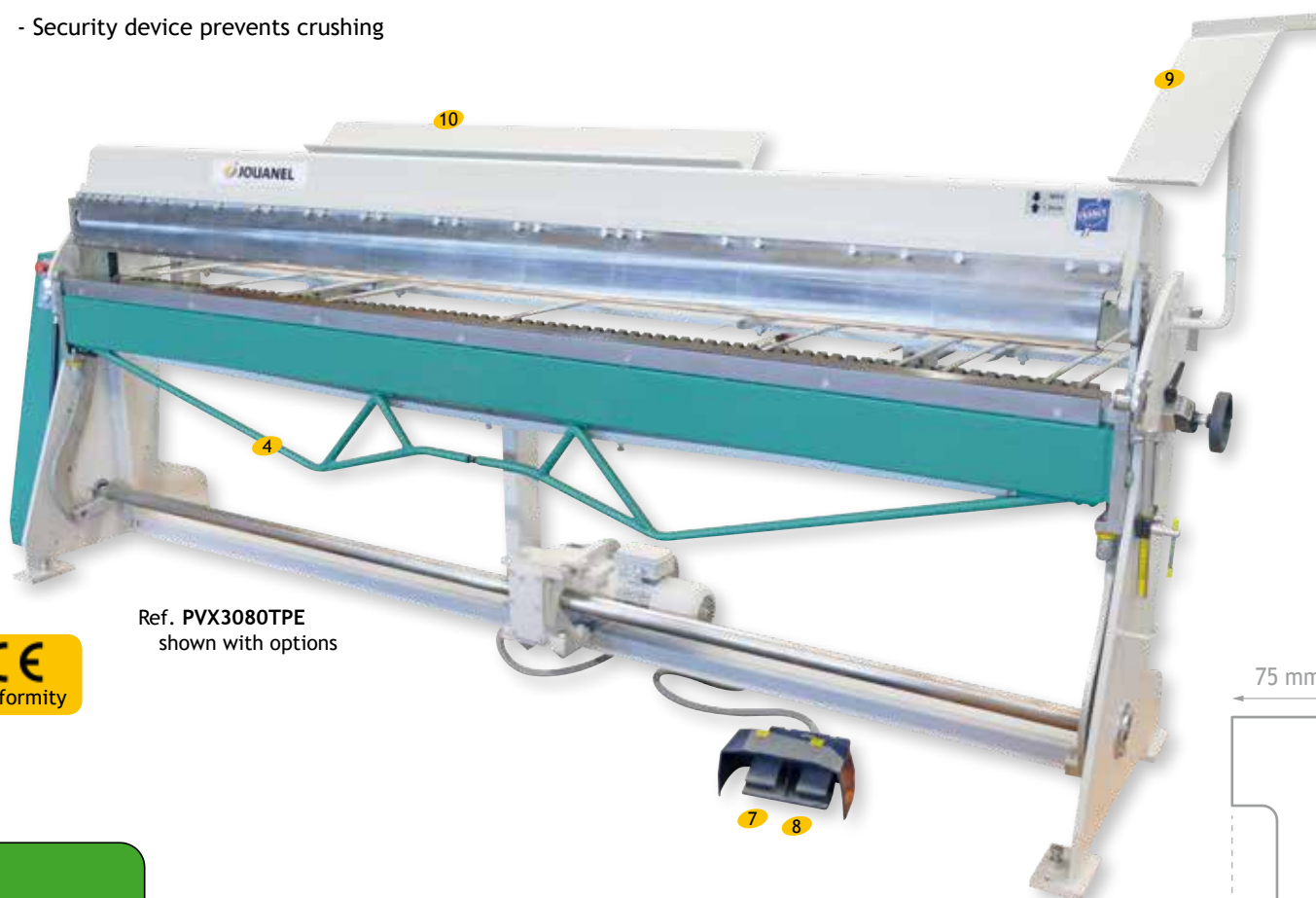

Ref. PVX3080TPE
shown with options

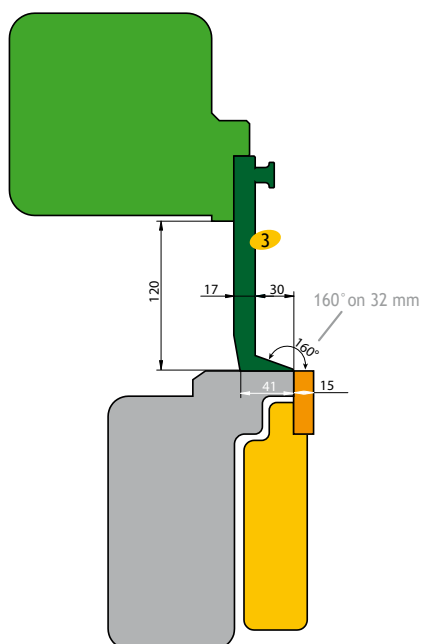

Standard equipment

- Quick disassembly of the segments with pull-device **1**
- Clamping beam with engraved segments (width of the segments)
- Left **2** and right corner segments (30 mm)
- Interchangeable clamping beam segmented tool: 20° **3**
- Automatic clamping beam lock
- Ergonomic folding beam **4** with narrow 15mm-tool for making close reverse bends
- Cylinder assists bending and ensures work reliability and rapidity, rotation of folding beam on needle roller bearings
- Graduated angle gauge **5**
- Angle scale **6**
- Clamping operated by foot pedal **7**
- Automatic clamping beam release once folding is complete
- Manual release operated by foot pedal **8**
- Vertical adjustment of the folding beam is easy using the graduated wheel, allowing the radius setting and facilitating reverse bends
- Console and tool support **9**
- Support for segments **10**
- Folding beam pins mounted on roller bearings



Semi-electric folding machines with segmented clamping beam - PVXTPE

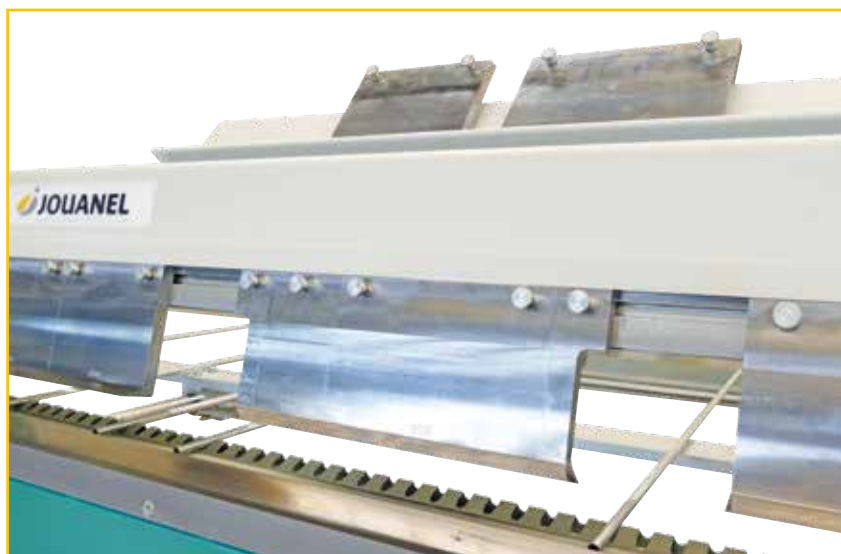
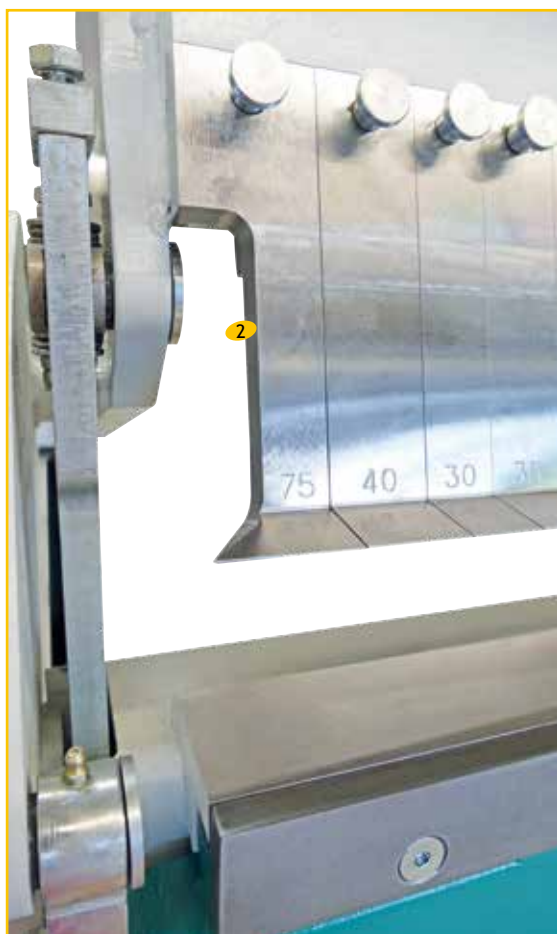

1 Quick disassembly of the segments with pull-device

5 Graduated angle gauge

6 Angle scale

Features	PVX2040TPE	PVX3080TPE
Useful folding length (mm)	2040	3080
Capacity zinc / S235JR steel (mm)*	1,2 / 1	1 / 0,8
Clamping beam tool angle	160°	160°
Clamping beam opening (mm)	95	95
Useful segment height (mm)	120	120
Dimensions (mm)	2 600 L x 800 l x 1400 H	3 600 L x 800 l x 1400 H
Gross weight (kg)	855	1130
Power supply (V)**	220 V single-phase	220 V single-phase
Power (kW)	0,25	0,25
Segments width (mm)	25, 30, 35, 50, 75, 75, 100, 150, 200, 200, 200, 300, 300, 300	25, 30, 35, 40, 50, 75, 75, 100, 100, 150, 150, 200, 200, 200, 250, 250, 250, 300, 300, 300

* Capacity with standard 15 mm-tool

** Voltage choice to be specified upon order

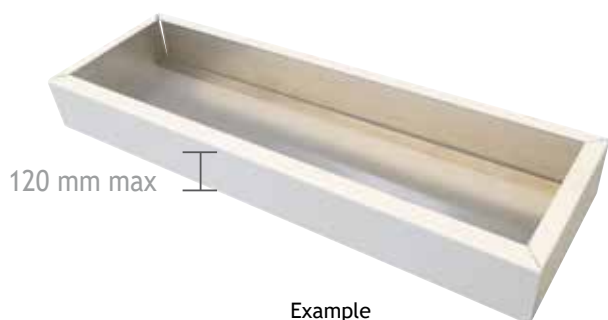

Options

- Additional narrow 12 mm-folding beam tool
Ref. PVX-REG12-2040 and PVX-REG12-3080 (capacity - 30%)
- Additional wide 20 mm-folding beam tool
Ref. PVX-REG20-2040 and PVX-REG20-3080 (capacity + 20%)
- Other options: see pages 15 to 17

Machine size available: in 2 m

Exist in semi-electric version

● PBS: the reliability in all its forms

Exists as standard in manual version.

For electric clamping and segmented clamping beam tool: please contact us.

- Folding beam equipped with a narrow and interchangeable tool of 15 mm and a wide tool of 25 mm in order to increase the folding capacity (refer to table for wide folding beam)
- Adjustable angle gauge with scale from 0 to 160° enabling to make accurate and identical folds
- Interchangeable clamping beam tool for the assembly of special tools.
- Clamping beam lifted up by a pedal enabling to keep hands free
- Quick locking of the clamping beam by eccentric
- Horizontal adjustment of the folding beam for the folding radius
- Lateral release allowing the passage of a sheet metal edge lifted up by 50 mm or a hem of Ø 18 mm to the top and 20 mm to the bottom

● Options: see pages 15 to 17



Ref. PBS2040-15 shown with options

Features	PBS2040-15	
Useful folding length (mm)	2 040	
Capacity (mm)	Wide 40mm folding beam tool	Narrow 15 mm folding beam tool
S235JR steel	1,5	1,0
1050-H44 aluminum / Zinc / Copper	2,0	1,2
Stainless steel	0,8	0,5
Galvanized steel	1,2	0,8
Clamping beam opening (mm)	80	
Dimensions (mm)	2 700 x 1 000 x 1 450	
Gross weight (kg)	680	

Minimum fold width: 15 times the thickness

Manual workshop folding machines - PVS

Machine sizes available: 2 m and 3 m



● PVS: automatic clamping beam opening device

Automatic release of the clamping beam when the folding beam lowers. JOUANEL patent which saves time by removing the opening operation.

Standard equipment

- Opening with 2 positions: 15 mm and 65 mm
- Folding beam bearings and clamping beam shaft fitted on double ball bearings
- Vertical adjustment of the folding beam enabling the radius setting and easily makes the reverse bend
- Clamping beam locking pedal accessible over the whole length of the machine
- Hollow clamping beam tool to close the folds
- Balance of the folding beam by spring providing flexibility and rapidity
- Clamping and folding beam tool made of steel
- Narrow folding beam tool: 15 mm as standard on Ref. PVS2050M
- Folding beam tool: 15 or 40 mm on Ref. PVS3080MR (to be specified upon order)

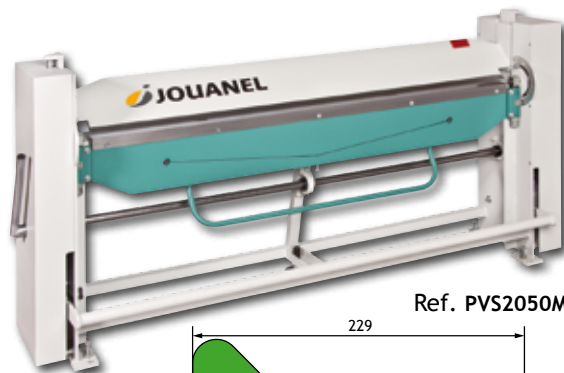

Ref. PVS2050M

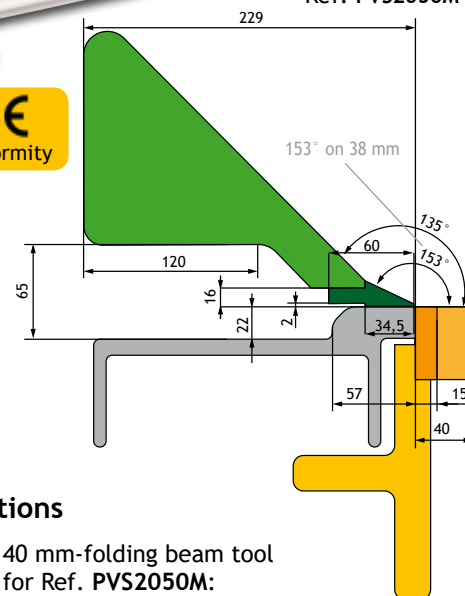

Features	PVS2050M		PVS3080MR	
Useful folding length (mm)	2 040		3 080	
Capacity (mm)	Wide 40mm folding beam tool	Narrow 15 mm folding beam tool	Wide 40mm folding beam tool	Narrow 15 mm folding beam tool
steel S235JR	1,5	1,0	1,2	0,8
1050-H44 aluminum	2,0	1,2	1,5	1,0
Stainless steel	0,8	0,6	0,6	0,5
Zinc, copper	1,6	1,0	1,6	1,0
Clamping beam opening (mm)	65		68	
Dimensions (mm)	2 535 x 570 x 1 265		3 535 x 570 x 1 265	
Gross weight (kg)	710		940	
Table height (mm)	930		930	

Minimum fold width = 15 times the thickness

● Options

- 40 mm-folding beam tool for Ref. PVS2050M: Ref. PVS-REG40-2M
- 15 or 40 mm-folding beam tool for Ref. PVS3080MR: Ref. PVS-REG15-3080 or Ref. PVS-REG40-3080
- Other options: see pages 15 to 17

Additional equipment for PCA, PCX, PZX, PVX, PBS, PVS

BACK GAUGES

Sliding back gauge type GAS 1

- For folding machines PBS, 2 adjustable gauge arms from 25 to 500 mm, Ref. **PBS-GAS**



Sliding back gauge type X 2

- For folding machine Ref. PCA2040, 2 adjustable gauge arms from 55 to 510 mm, Ref. **PCAB2040**
- For folding machine Ref. PCA2040, adjustable gauge arm from 55 to 510 mm, Ref. **PCABS2**
- For folding machine Ref. PCX1020, 2 adjustable gauge arms from 40 to 510 mm, Ref. **PCXB1020**
- For folding machines Ref. PCX2040A and PZX2040, 2 adjustable gauge arms from 40 to 510 mm, Ref. **PCXB2040**
- For folding machines Ref. PCX2540A and PZX2540, 2 adjustable gauge arms from 40 to 510 mm, Ref. **PCXB2540**
- For folding machines Ref. PCX1020, PCX2040A, PCX2540A and PZX2040, PZX2540, additional gauge arm from 40 mm to 510 mm, Ref. **PCXBS2-2.5**
- For folding machine Ref. PCX3080A, 2 adjustable gauge arms from 65 to 530 mm, Ref. **PCXB3040**
- For folding machine Ref. PCX3080A, additional gauge arm from 65 to 530 mm, Ref. **PCXBS3**
- For folding machines Ref. PVX2040, Ref. PVX2040T, Ref. PVX2040PE, Ref. PVX2040TPE, 2 adjustable gauge arms from 60 to 750 mm, Ref. **PVXB2040**
- For folding machines Ref. PVX3080, Ref. PVX3080T, Ref. PVX3080PE, Ref. PVX3080TPE, 2 adjustable gauge arms from 60 to 750 mm, Ref. **PVXB3080**
- For folding machines Ref. PVX2040, Ref. PVX2040T, Ref. PVX2040PE, Ref. PVX2040TPE, Ref. PVX3080, Ref. PVX3080T, Ref. PVX3080PE, Ref. PVX3080TPE, additional gauge arm: 750 mm, Ref. **PVXBS-C750**
- For folding machines Ref. PVS2050M and PVS3080MR 2 adjustable gauge arms from 60 to 750 mm, Ref. **PVSB2040** and **PVSB3080**
- For folding machines Ref. PVS2050M and PVS3080MR additional gauge arm up to: 750 mm, Ref. **PVSB-C750**



Rack-operated back gauge type GAC, equipped with a digital counter 3

- For folding machines Ref. PBS2040 and Ref. PBS2540, adjustable from 25 to 500 mm, Ref. **GAC-PZA-PBS-PZS**



Belt-type back gauge 4

Gauge equipped with 4 repositionable fingers over the length, setting of the gauge by digital counter 5, lateral control

- For folding machine Ref. PVS2050M adjustable gauge from 5 to 500 mm, Ref. **PVSB2040**
- For folding machine Ref. PVS3080MR adjustable gauge from 5 to 750 mm, Ref. **PVSB3080**
- For folding machines Ref. PVX2040, Ref. PVX2040T, Ref. PVX2040PE, Ref. PVX2040TPE, adjustable gauge from 5 to 750 mm, Ref. **PVXBC2040**
- For folding machines Ref. PVX3080, Ref. PVX3080T, Ref. PVX3080PE, Ref. PVX3080TPE, adjustable gauge from 5 to 750 mm, Ref. **PVXBC3080**
- For folding machines Ref. PVX2040, Ref. PVX2040T, Ref. PVX2040PE, Ref. PVX2040TPE, adjustable gauge from 5 to 750 mm, Ref. **PVXBC2040**
- For folding machine Ref. PZX2040, adjustable gauge from 5 to 750 mm, Ref. **PZXBC2040**

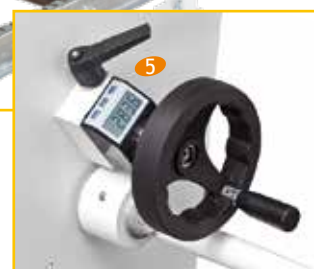
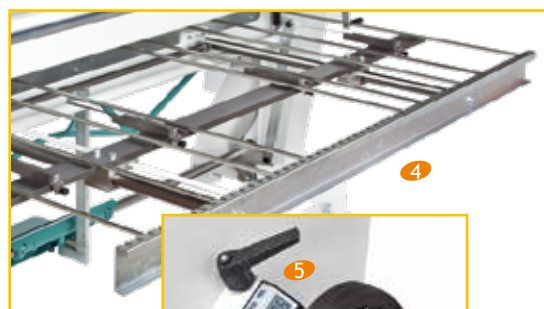

Additional equipment for PCA, PCX, PZX, PVX, PBS, PVS

WORKSHOP BENCH AND BACK TABLES

Zinc workbench adapted to folding machine ⁶

Length 2 090 x 1 500 mm
Table with incorporated setting tools for metal sheet tracing
3 storage levels and 4 racks

- For folding machine Ref. PBS2040, Ref. ETB2040

Workshop bench equipped with cutting accessories and clamping beam with guide rail (OPTIONS)



Back table for folding machine ⁷

Table equipped with full lengthwise tool
Integrated and adjustable sliding back gauge

- Length 2 000 mm x 1 280 mm

- For folding machine Ref. PCX2040A, Ref. ETBX2040C gauge stroke 45 to 1000 mm
- For folding machine Ref. PZX2040, Ref. ETBX2040 gauge stroke 60 to 1000 mm
- For folding machines Ref. PVX2040, Ref. PVX2040T, Ref. PVX2040PE, Ref. PVX2040TPE Ref. ETBX2040V gauge stroke 60 to 1000 mm

- Length 2 500 mm x 1 280 mm

- For folding machine Ref. PCX2540A, Ref. ETBX2540C gauge stroke 45 to 1000 mm
- For folding machine Ref. PZX2540, Ref. ETBX2540 gauge stroke 60 to 1000 mm



BEADING ACCESSORIES

Beading accessory with gear train: 14, 16 or 18 mm Ø, type ABH and ABV

(Please specify the Ø upon order)

- For folding machine Ref. PCX1020 Ref. ABH14-1020 / Ref. ABH16-1020 / ABH18-1020
- For folding machines Ref. PCX2040A and PZX2040 Ref. ABH14-16-2040 / ABH18-2040
- For folding machines Ref. PCX2540A and PZX2540 Ref. ABH16-2540 / ABH18-2540
- For folding machine Ref. PCX3080A Ref. ABH16-3080 / ABH18-3080
- For folding machine Ref. PBS2040 Ref. ABH14-16-2040BS / ABH18-2040BS
- For folding machine Ref. PVS2050M Ref. ABH14-16-2040VS / ABH18-2040VS
- For folding machine Ref. PVS3080MR Ref. ABH16-3080VS / ABH18-3080VS
- For folding machines Ref. PVX2040, Ref. PVX2040T Ref. PVX2040PE, Ref. PVX2040TPE :
..... Ref. ABV14-16-2040 / ABV18-2040
- For folding machines Ref. PVX3080, Ref. PVX3080T Ref. PVX3080PE, Ref. PVX3080TPE :
..... Ref. ABV16-3080 / ABV18-3080

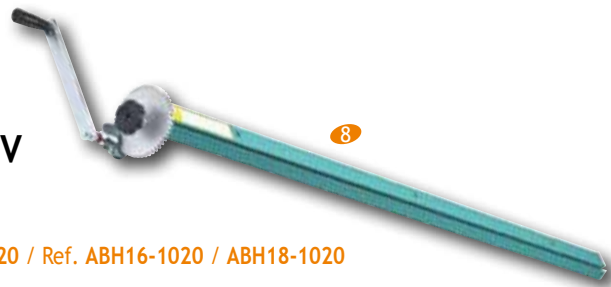

Capacity of beading accessory with gear train* (mm)	ABH/ABV			
	1020	2040	2540	3080
Ø 14	0,80	0,65	-	-
Ø 16	1,00	0,80	0,65	0,55
Ø 18	1,00	0,80	0,80	0,70

* Capacity zinc or copper (in mm)

Beading accessory with gear train Ø 14, 16 mm type ABA (Specify the Ø upon order)

- For folding machine Ref. PCA2040 Ref. ABA2040



Zinc capacity (mm)	ABA2040
14-mm Ø rod (make a bead with 16-mm outer. Ø)	0,65
16-mm Ø rod (make a bead with 18-mm outer. Ø)	0,80

CUTTING ACCESSORIES

RCS and RGS: Guide rails ⁹ (for CCM roller shear)

- For folding machine Ref. PCX1020 Ref. RCX1020
- For folding machine Ref. PCX2040A Ref. RCX2040A
- For folding machines Ref. PCX2540A and PZX2540 Ref. RCX2540A
- For folding machine Ref. PCX3080A Ref. RCX3080
- For folding machine Ref. PBS2040 Ref. RGS2040A



Roller shear: CCM ¹⁰ (guide rail required)

- Handy, robust aluminum body
- Tempered steel rollers for a longer lifespan
- Guide rail and 2 grip handles for an accurate cut
- Capacity zinc 0,8 mm, steel 0,63 mm



Guide rail: RCA, RZX and RVX ¹¹ (for roller shear CCMA)

- For folding machine Ref. PCA2040, Ref. RCA2040
- For folding machine Ref. PZX2040, Ref. RZX2040A
- For folding machine Ref. PVX2040, Ref. RVX2040
- For folding machine Ref. PVX3080, Ref. RVX3080

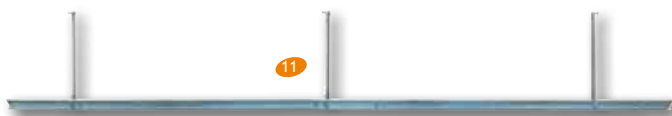

Roller shear: CCMA ¹² (guide rail required)

- Handy, robust aluminum body
- Tempered steel rollers for a longer lifespan
- Guide rail and 2 grip handles ensure an accurate cut
- Capacity zinc 0,8 mm - steel 0,7 mm - 1050-H44 aluminum 0,8 mm



MISCELLANEOUS



180° Hem closing tool: OFP-180

for regular folding over the whole length

- From a seam at 135° it enables a plating at 180°
- Sets of 4 rollers
- Adjustable final roller for a perfect setting, according to material and thickness
- Folding capacity 0,8 mm steel



 YouTube
DEMONSTRATION VIDEO
available on YouTube® / Channel "Jouanel Industrie"



Segmented folding machines - HS

- Folding machines type HS23, HS33: segmented clamping beam, table and folding beam

On the top or on the bottom, or bend all 4 sides!

This powerful and handy segmented folding machine is specially designed for folding parts requiring complex shapes. With various positioning possibilities of the upper and lower segments, enjoy the freedom of manufacturing different types of boxes, for roofing, cladding, chimney siding and trim, etc.

Machine sizes available: 1 m and 1,25 m

Standard equipment

- Segmented clamping beam, table and folding beam 1
- Clamping foot pedal keeps hands free during positioning and adjustment of the part to be folded 2
- Automatic clamping beam lock 3
- Left 4 and right corner segments
- Folding beam height adjustment to change the folding radius according to the thickness of the material 5
- Adjustment of the height and the clamping pressure 6
- Angle gauge adjustment for series folding
- Segments in tempered steel
- Two handles to operate the folding beam
- Key for segment removal included



Ref. HS23



DEMONSTRATION VIDEO
available on YouTube® / Channel
"Jouanel Industrie"

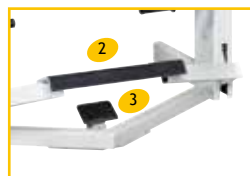
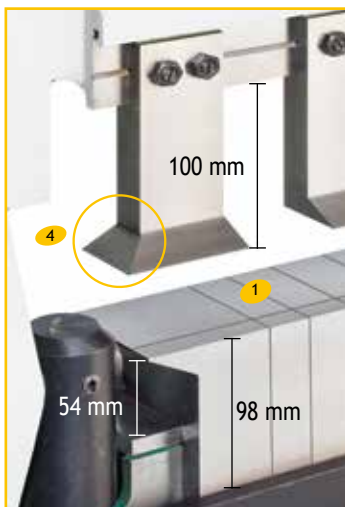

Examples of works made with ref. HS23 or HS33

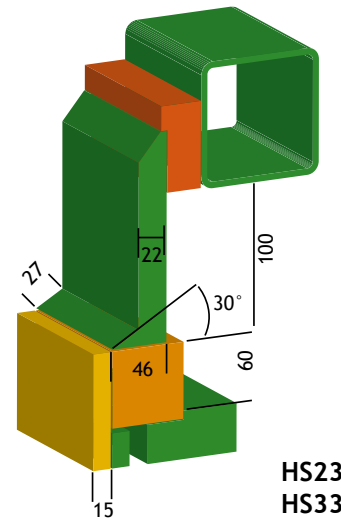
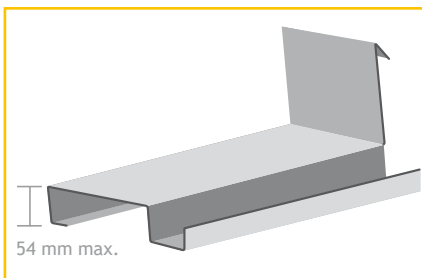
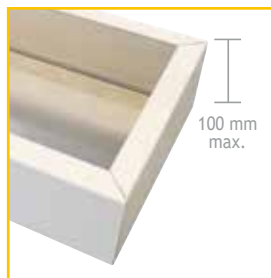

HS23
HS33

Features	HS23	HS33
Useful folding length (mm)	1 020	1 270
Capacity stainless steel / 1050-H44 aluminum (mm)	1,2 / 2,5	1 / 2
Capacity S235JR steel (mm)	2	1,5
Maximum folding angle	150°	150°
Clamping beam opening (mm)	50	50
Height of the table segments (mm)	54	54
Height of the folding beam segments (mm)	98	98
Useful segment height (mm)	100	100
Dimensions (mm)	1 350 x 850	1 600 x 900
Gross weight (kg)	385	415

Segments distribution - HS23

No of segments: 12										
Width (mm)	25	30	35	40	45	50	75*	100	200	270
Quantity	1	1	1	1	1	1	3	1	1	1

Segments distribution - HS33

No of segments: 13											
Width (mm)	25	30	35	40	45	50	75*	100	200	250	270
Quantity	1	1	1	1	1	1	3	1	1	1	1

*For width of 75 mm: 1 straight segment, 1 left corner segment and 1 right corner segment

* For a width of 75 mm: 1 straight segment, 1 left corner segment and 1 right corner segment

Segmented folding machines - HS

Folding machines type HS2S, HS3S: segmented clamping beam and folding beam

A universal and multi-purpose folding machine!

This manual segmented folding machine is strong, easy to handle and above all versatile. It can be used both as classical folding machine with the added advantage of a very good folding capacity and by using the segments, designed to shape low-height boxes.

These machines are perfectly suitable for metalwork in small series in steel, stainless steel or alu, up to 2.5 mm depending on the used material.

Machine sizes available: 1 m and 1,25 m

Standard equipment

- Segmented clamping beam and folding beam 1
- Clamping foot pedal keeps hands free during positioning and adjustment of the part to be folded 2
- Automatic clamping beam lock 3
- Folding beam height adjustment to change the folding radius according to the thickness of the material 4
- Adjustment of the height and the clamping pressure 5
- Angle gauge adjustment for series folding
- Segments in tempered steel
- Central lever to operate the folding beam
- Key for segment removal included



Ref. HS2S

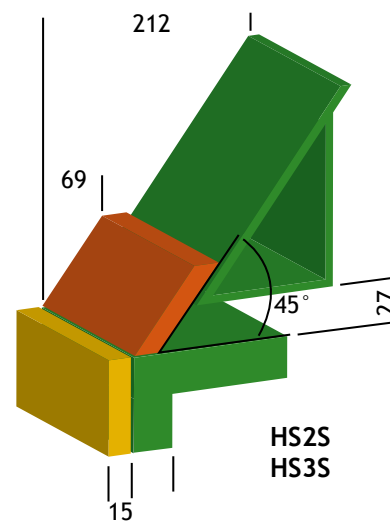
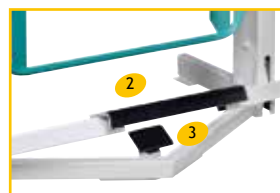
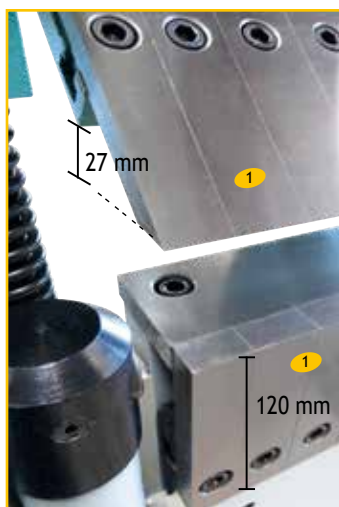

Features	HS2S	HS3S
Useful folding length (mm)	1 020	1 270
Capacity stainless steel / 1050-H44 aluminum (mm)	1,2 / 2,5	1 / 2
Capacity S235JR steel (mm)	2	1,5
Maximum folding angle	135°	135°
Clamping beam opening (mm)	45	45
Height of the folding beam segments (mm)	120	120
Useful segment height (mm)	27	27
Dimensions (mm)	1 350 x 850	1 600 x 900
Gross weight (kg)	310	360

Segments distribution - HS2S

No of segments: 11											
Width (mm)	25	30	35	40	45	50	75	100	150	200	270
Quantity	1	1	1	1	1	1	1	1	1	1	1

Segments distribution - HS3S

No of segments: 12												
Width (mm)	25	30	35	40	45	50	75	100	150	200	250	270
Quantity	1	1	1	1	1	1	1	1	1	1	1	1

Universal electric FOLDING MACHINES

PTL - PTS

Suitable for thin or thick sheets



PTL

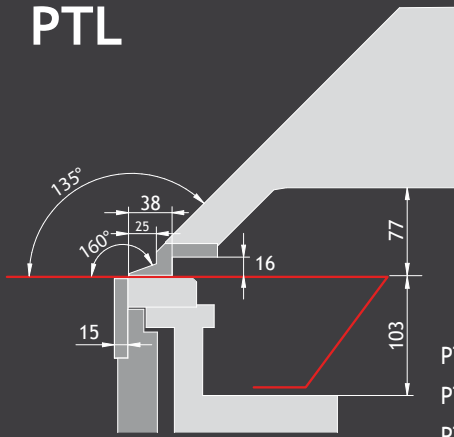

PTL2100-18
PTL2600-15
PTL3100-12

Clamping beam tool radius: 1.0mm
2 and 3mm radius also available on demand



Model PTL3100-12
without CNC

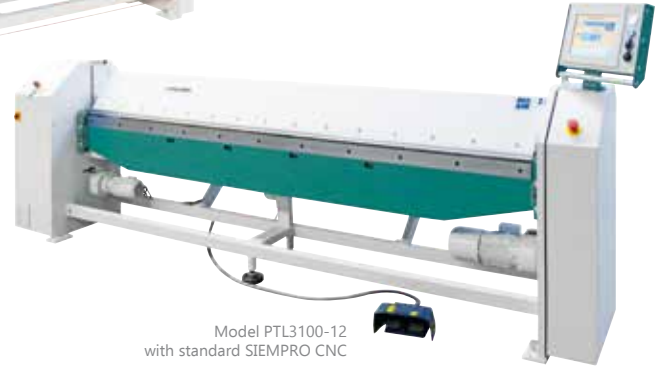

Model PTL3100-12
with standard SIEMPRO CNC

VIDEOS

www.jouanel.com

PTL folding machines available in sizes: 2 m, 2,60 m and 3 m

PTS

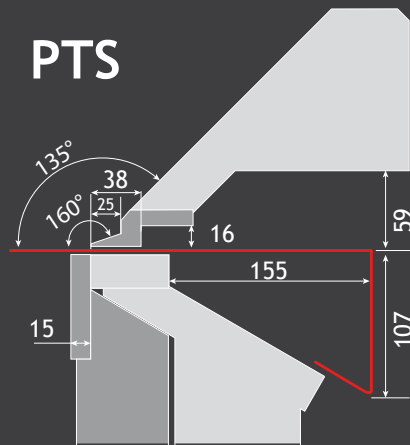

PTS2100-20
PTS2600-18
PTS3100-15
PTS4100-10

Clamping beam tool radius: 1.0mm
2 and 3mm radius also available on demand

VIDEOS

www.jouanel.com



Model PTS3100-15
with dynamic graphic CNC

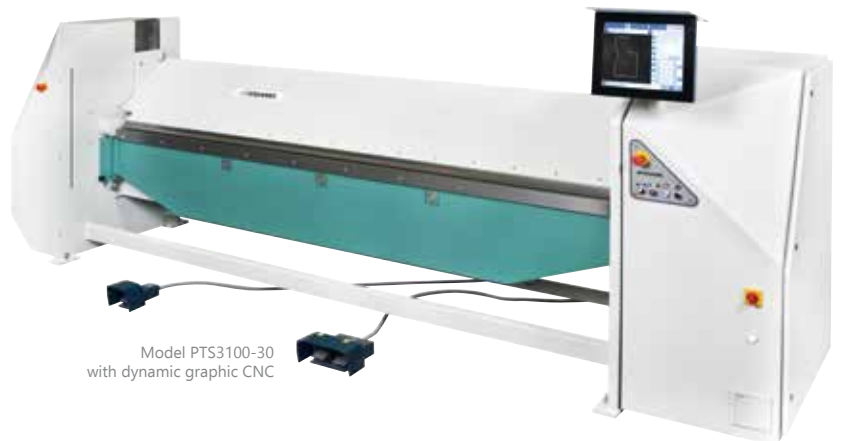

Model PTS3100-30
with dynamic graphic CNC

PTS folding machines available in sizes: 2m, 2,60m, 3m and 4m

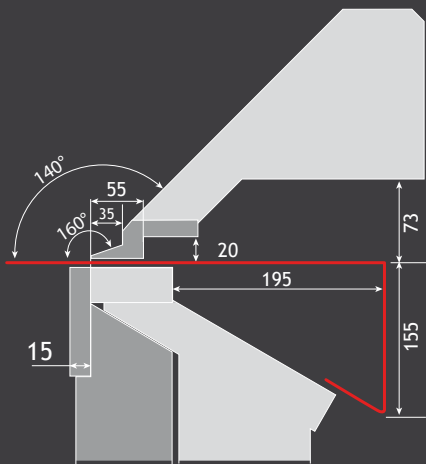

PTS2100-40
PTS2600-35
PTS3100-30
PTS4100-20

Clamping beam tool radius: 1.5mm
2 and 3mm radius also available on demand

Universal electric folding machines PTL - PTS

The appropriate combination of working length, bending capacity and numerical control choice shows you the motorized folding machine you need.

Technical characteristics	PTL2100-18	PTL2600-15	PTL3100-12
Useful folding length (mm)	2 100	2 600	3 100
Capacity S235JR steel (mm) with folding beam 25mm *	1.8	1.5	1.2
Capacity S235JR steel (mm) with folding beam 15mm *	1.2	1.0	0.8
Capacity 1050-H44 aluminum (mm) with folding beam 25mm *	2.5	2.0	1.75
Capacity 1050-H44 aluminum (mm) with folding beam 15mm *	1.75	1.5	1.2
Table height (mm)	835		
Clamping beam tool angle	20°		
Clamp opening (mm)	130		
Folding speed (°/s)	60		
Clamping speed without safety light curtains (mm/s)	10		
Clamping speed with safety light curtains (mm/s)	40		
Power supply (V) **	400 V three-ph + neutral + ground		
Total power (kW)	1.5		
Dimensions without electric back gauge (LxWxH) (mm)	2 970 x 620 x 1 190	3 470 x 620 x 1 190	3 970 x 620 x 1 190
Gross weight (kg) without electric back gauge	1400	1600	1800

* 90° bending capacities / Minimum fold width = 15 times the thickness • ** Electrical voltage to be specified upon order

Technical characteristics	PTS2100-20	PTS2100-40	PTS2600-18	PTS2600-35	PTS3100-15	PTS3100-30	PTS4100-10	PTS4100-20
Useful folding length (mm)	2 100	2 100	2 600	2 600	3 100	3 100	4 100	4 100
Capacity S235JR steel (mm) with 25mm folding beam and standard folding beam tool *	2.0	4.0	1.8	3.5	1.5	3.0	1.0	2.0
Capacity S235JR steel (mm) with 15mm folding beam and standard folding beam tool *	1.5	2.0	1.25	1.8	1.0	1.5	0.8	1.2
Capacity 1050-H44 aluminium (mm) with 25mm folding beam and standard folding beam tool *	3.0	5.0	2.5	4.5	2.0	4.0	1.5	2.5
Capacity 1050-H44 aluminium (mm) with 15mm folding beam and standard folding beam tool *	2.0	3.0	1.8	2.75	1.5	2.5	1.0	1.8
Table height (mm)	830							
Clamping beam tool angle	20°							
Clamp opening (mm)	130	240	130	240	130	240	130	240
Folding speed (°/s)	60							
Clamping speed without safety light curtains (mm/s)	10							
Clamping speed with safety light curtains (mm/s)	40							
Power supply (V) **	400 V three-ph + neutral + ground							
Total power (kW)	2.6	9	2.6	9	2.6	9	2.6	9
Dimensions without electric back gauge (LxWxH) (mm)	3 260 x 865 x 1 800	3 600 x 1 005 x 1 900	3 760 x 865 x 1 800	4 100 x 1 005 x 1 900	4 260 x 865 x 1 800	4 600 x 1 005 x 1 900	5 260 x 865 x 1 800	5 600 x 1 005 x 1 900
Gross weight (kg) without electric back gauge	1900	3300	2200	3500	2500	3800	2900	4600

* 90° bending capacities / Minimum fold width = 15 times the thickness • ** Electrical voltage to be specified upon order

Numerical control for PTL and PTS folding machines



STANDARD "SIEMPRO" CNC

Simplified numerical control

- Colour touchscreen, adjustable
- Possibility to work either in manual mode or in automatic mode after quick creation of the programs
- Management of the metal sheet position before folding
- Management of rotating, flipping and turning over parts
- Unlimited creation of programs
- Fast duplication of the programs
- Safe access secured by password depending on the operator's tasks (programming, use of program) or without password
- Counting up and down of produced parts
- Folding angle correction in manual mode according to metal elasticity (type, thickness)
- Maintenance management by numerical control (automatic reminder of periodical interventions, intervention history)
- Remote maintenance and updates via Ethernet connection (RJ45)
- Multilingual CNC



VIDEOS
www.jouanel.com

Main menu



Execution mode



Program mode

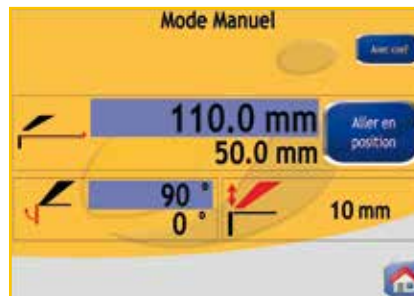

Manual mode

Optional equipment SIEMPRO

- Electric back gauge PTSL-BAE (option to be specified upon order)

Electric back gauge BAE	PTL 2100-18	PTL 2600-15	PTL 3100-12
Back gauge range	10 to 750mm		
Back gauge speed	300mm/s forward 500mm/s reverse		
Number of back gauge fingers	6	8	8
Min. distance between 2 fingers (mm)	100mm		

- CNC control of the clamping beam lock and precise height adjustment (Z-axis) Ref. PTSL-SIEMPRO-Z (to be specified upon order)
- Automatic angle controller, maximum thickness 1mm, Ref. PTSL-CORANG-SIEMPRO (to be specified upon order)

PROFILES Examples



Numerical control for PTL and PTS folding machines



DYNAMIC GRAPHIC CNC

Very intuitive numerical control to easily draw profiles on the touchscreen

- 19" touchscreen with mobile protection cover
- Different access codes for programmer/maintenance/execution
- Automatic management of the clamping beam position (opening and closing)
- Folding beam speed control
- Back gauge speed control
- SmartPath software: automatic analysis of profile feasibility, several sequences suggested
- Calculation of collision prevention with the clamping beam
- Library of profile parts with a quick search
- Programming choice, by table or profile drawing
- Creation, duplication and modification of programs
- Stamping without moving the folding beam, choice of three intervals between successive bends
- Automatic management of flipping and turning over parts
- Counting up and down of the produced parts
- Possibility to save all data via USB port
- Remote diagnosis and update via Ethernet connection (RJ45)
- Web application « EDGE »
- Multilingual CNC

VIDEOS

www.jouanel.com



Automatic analysis of profile feasibility, several sequences suggested



Automatic management of rotating, flipping and turning parts over



Create curved shapes with stamping mode



Web application EDGE

With only a tablet or connected PC!

With the EDGE web application, you can, from a PC or a tablet, draw your parts to be folded, check their feasibility and export them directly to the graphic CNC of your folding machine

Up to 20 users at the same time

- No more mistakes when relaying parts to be folded
- Transmits needs to the folding workshop in real time
- Immediate analysis of the profile feasibility outside the workshop
- Digital profile library with sorting options (building sites, customers...)

Optional equipment GRAPH

- Bending angle springback mode (angle correction), maximum thickness 1mm, Ref. PTSL-CORANG-GRAF (to be specified upon order)



Equipment comparison table for PTL and PTS folding machines

MACHINE REFERENCES	PTL range			PTS range							
	PTL 2100-18	PTL 2600-15	PTL 3100-12	PTS 2100-20	PTS 2100-40	PTS 2600-18	PTS 2600-35	PTS 3100-15	PTS 3100-30	PTS 4100-10	PTS 4100-20
Folding length (mm)	2 100	2 600	3 100	2 100	2 100	2 600	2 600	3 100	3 100	4 100	4 100
Numerical control	Operates with or without CNC			Operates exclusively with a standard or graphic CNC (see optional equipment)							
EQUIPMENT INCLUDED											
2 interchangeable 15 and 25mm folding beam tools	•	•	•	•	•	•	•	•	•	•	•
1 Interchangeable clamping beam tool at 20°	•	•	•	•	•	•	•	•	•	•	•
Folding beam crowning device	•	•	•	•	•	•	•	•	•	•	•
Adjustment of the folding radius	•	•	•	•	•	•	•	•	•	•	•
Automatic bending cycle (productivity +25%)	•	•	•	•	•	•	•	•	•	•	•
Electromechanical angle gauge	•	•	•								
Control by 2 operators			•					•	•	•	•
CNC control of the clamping beam position (Z-axis)				•	•	•	•	•	•	•	•
OPTIONAL EQUIPMENT	To be specified upon order										
Standard SIEMPRO numerical control (without back gauge) - See Page 22	•	•	•	•	•	•	•	•	•	•	•
DYNAMIC GRAPHIC numerical control (without back gauge)											
Included : CNC control of the clamping beam position and height adjustment, EDGE application See Page 23	•	•	•	•	•	•	•	•	•	•	•
Electric back gauge 750mm* (2)	•	•	•	•	•	•	•	•	•	•	•
Electric back gauge 1 000mm* (2)	•	•	•	•	•	•	•	•	•	•	•
Electric back gauge 1 500mm* (composed of 2 lines of gauge fingers)(2)**	•	•	•	•	•	•	•	•	•	•	•
Manual sliding back gauge 750mm*	•	•	•								
CNC control of the clamping beam position (Z-axis) (1)	•	•	•								
Automatic angle correction (2)	•	•	•	•	•	•	•	•	•	•	•
Safety light curtains (2) CE conformity : 2006/42/CE	•	•	•	•	•	•	•	•	•	•	•
Control console on swivel arm (2)	•	•	•	•	•	•	•	•	•	•	•
Folding beam tools 8, 10 or 12mm	•	•	•	•	•	•	•	•	•	•	•
Conical folding (3) Manual adjustment on mechanical counter			•	•		•		•		•	
Conical folding (3) Manual pneumatic adjustment**					•		•		•		•
Control pedal on ground rail	•	•	•	•	•	•	•	•	•	•	•
Single-phase power supply 230 V instead of 400 V three-phase	•	•	•	•		•		•		•	
Set of fully retractable gauge fingers** Manual control button (3)	•	•	•	•	•	•	•	•	•	•	•
Segmented clamping beam tool*					•		•		•		•

*Find more information on our back gauges and segmented clamping beam tools in our PTL/PTS brochure

**These options require air supply: please contact us

(1) This option requires standard numerical control SIEMPRO (equipment included in the PTS range of folding machines)

(2) This option requires numerical control

(3) This option requires electrical back gauge

Equipment comparison table for PTL and PTS folding machines

Equipment included

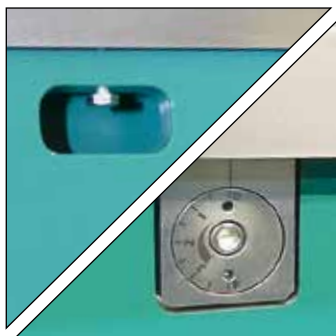

Folding beam crowning device (depending on the model)



Adjustment of the folding radius

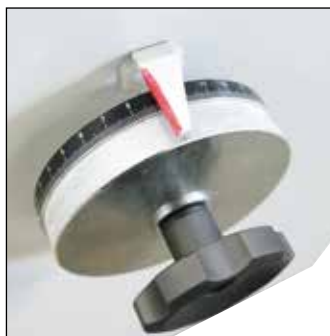

Electromechanical angle gauge



Mode selection: 1 or 2 operators

Optional equipment



Standard SIEMPRO CNC
Ref. PTSL-CNC-SIEMPRO



Dynamic graphic CNC
Ref. PTSL-CNC-GRAP



Electric back gauge, maximum range 750, 1000 or 1500mm - Ref. PTSL-BAE

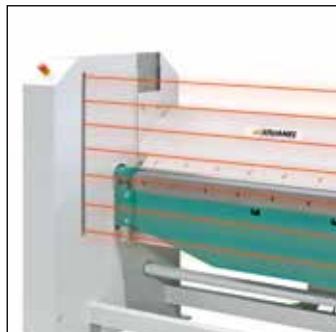

Safety light curtains - Ref. PTSL-SPEED-Z



Control console on swivel arm
Ref. PTSL-CNC-POT



Manual sliding back gauge, maximum range 750mm - Ref. PTL-BAM



Conical folding, manual adjustment



Pneumatic conical folding, manual adjustment



Control pedal on ground rail - Ref. PTSL-PEDRAIL

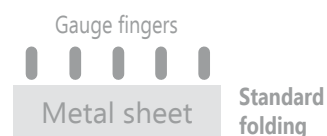

Extra long folding machines - PGL 4 to 12 metres

● Extra long folding machines: PGL

Machine sizes available: 4, 6, 8, 10 and 12 m

- Welded steel construction, machined and heavy-duty to guarantee high rigidity
- Useful folding depth: 1250 mm (gooseneck)
- 30 mm folding beam
- Interchangeable clamping beam tool: 40°
- Clamping beam opening: 200 mm
- Automatic adjustment of the gooseneck to adapt the clamping beam position to the thickness of the metal sheet used (for models of Capacity S235JR steel: 2 and 3 mm)
- Additional interchangeable folding beam tool 15 mm (4ZCD4)
- Double operator control
- CE Conformity

Note: Machine Ref. PGL does not work without numerical control

Choice of numerical control

Numerical control SIEM-PRO

- 10" colour touchscreen (OPTION: 15" touchscreen)
- Access code programmer / maintenance / execution
- Automatic control of back gauge, stroke from 25-1250 mm, with double back gauge fingers
- Automatic speed control of the back gauge
- Automatic operator commands given, indicating when to rotate, flip and turn parts over
- Count and countdown of produced parts
- Angle correction control (manual input) according to the thickness and the material
- Remote assistance and updates via Ethernet connection (RJ45)
- Bending angle springback mode Ref. COR-ANG-CN (OPTION)



Touchscreen views
Ref. SIEM-PRO

Dynamic graphic numerical control PGL-GRAPH

- Dynamic graphic 19" colour touchscreen with mobile protection box
- Access code for programmer/maintenance/execution
- Safe workstation with safety light curtains activated, allowing fast and safe closing and locking of the clamping beam (standard EC 2009)
- Material library
- Automatic analysis of profile feasibility, several sequences suggested
- Parts library: large program storage capacity
- Automatic creation of programs in graphic mode
- Choice to program by drawing a profile, or by inputting bends step-by-step
- Automatic control of the clamping beam position (opening and closing)
- Folding beam speed control (90° max/second) and automatic folding angle correction (manual input) depending on material thickness
- Duplication and modification of programs
- Stamping without moving the folding beam, choice of three intervals between successive bends
- Folding simulation with calculation of collision prevention with the clamping beam
- Automatic operator commands given, indicating when to rotate, flip and turn parts over
- Count and countdown of produced parts
- Electric back gauge with 2 positions in automatic management
 - Accuracy ± 0.1 mm
 - Automatic speed control
 - Back gauge stroke 25 to 1300 mm
 - Forward speed 300 and reverse speed 500 mm/s
- Remote diagnosis and updates via Ethernet connection (RJ45)
- Bending angle springback mode Ref. COR-ANG-PGL (OPTION)
- Web application « EDGE » to create programs remotely and export them to the folding machine

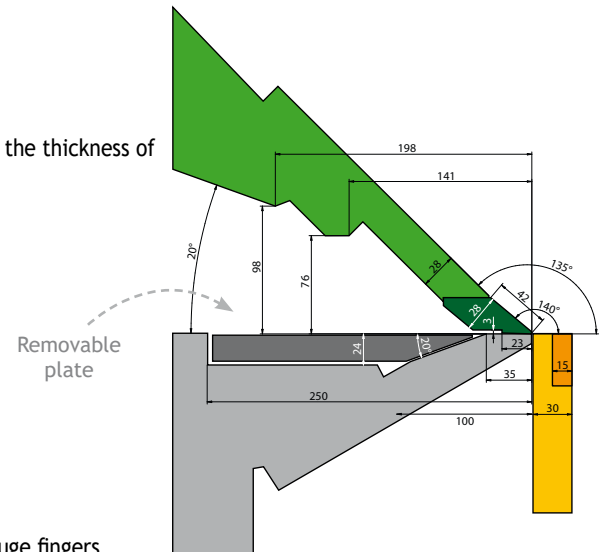

1 Double back gauge fingers

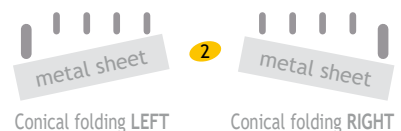

Drawing of a profile directly on the screen



Large program capacity

Extra long folding machines - PGL 4 to 12 metres



Examples

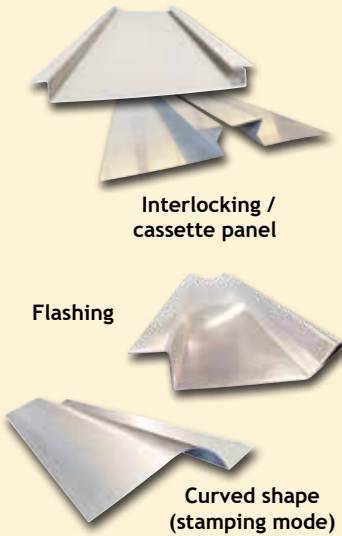

Interlocking /
cassette panel

Flashing

Curved shape
(stamping mode)

Options

- 15" Colour touchscreen for numerical control Ref. **SIEM-PRO**
- Bending angle springback mode (angle correction), max. thickness 1 mm:
 - Ref. **COR-ANG-CN** for numerical control Ref. **SIEM-PRO**
 - Ref. **COR-ANG-PGL** Graphic dynamic numerical control Ref. **PGL-GRAPH**
- Additional double back gauge fingers **1** (to be specified upon order)
- Pneumatic device for conical folding **2**, easily makes interlocking profiles
- Hydraulic roller shear Ref. **PGL-COUT** **3**
 - Equipped with removable sheet support for wide strips
 - Adjustable angle and blade clearance depending on material thickness
 - Capacity S235JR steel: 1.5 or 3 mm
- Worktable on wheels
 - 4 000 x 1 000 x 930 mm Ref. **PGL-TABLE4**
 - 6 000 x 1 000 x 930 mm Ref. **PGL-TABLE6**



Ref. **PGL6000-3**
shown
with options



Ref. **PGL6000-3**
shown
with options



2 Pneumatic conical
adjustment thumbwheel



3 Hydraulic roller
shear Ref. **PGL-COUT**



DEMONSTRATION VIDEO

available on YouTube® / Channel "Jouanel Industrie"



Reference	Useful folding length (mm)	Capacity S235JR steel (mm)	Angle of the clamping beam tool	Clamping beam opening (mm)	Power supply*	Power (kw)	Dimensions l x w x h (mm)	Folding Beam thickness (Added tool /Folding beam)
PGL4000-15	4 050	1,5	40°	200 mm	400 V three-ph + neutral + earth	5,5	4 365 x 1 785 x 1 500	15/30
PGL4000-2	4 050	2,0	40°	200 mm	400 V three-ph + neutral + earth	5,5	4 365 x 1 785 x 1 500	15/30
PGL4000-3	4 050	3,0	40°	200 mm	400 V three-ph + neutral + earth	5,5	4 365 x 1 785 x 1 500	15/30
PGL6000-15	6 050	1,5	40°	200 mm	400 V three-ph + neutral + earth	5,5	6 365 x 1 785 x 1 500	15/30
PGL6000-2	6 050	2,0	40°	200 mm	400 V three-ph + neutral + earth	7,5	6 365 x 1 785 x 1 500	15/30
PGL6000-3	6 050	3,0	40°	200 mm	400 V three-ph + neutral + earth	7,5	6 365 x 1 785 x 1 500	15/30
PGL8000-15	8 050	1,5	40°	200 mm	400 V three-ph + neutral + earth	9	8 365 x 1 785 x 1 500	15/30
PGL8000-2	8 050	2,0	40°	200 mm	400 V three-ph + neutral + earth	11	8 365 x 1 785 x 1 500	15/30
PGL8000-3	8 050	3,0	40°	200 mm	400 V three-ph + neutral + earth	11	8 365 x 1 785 x 1 500	15/30
PGL10000-15	10 050	1,5	40°	200 mm	400 V three-ph + neutral + earth	11	10 365 x 1 785 x 1 500	15/30
PGL10000-2	10 050	2,0	40°	200 mm	400 V three-ph + neutral + earth	15	10 365 x 1 785 x 1 500	15/30
PGL10000-3	10 050	3,0	40°	200 mm	400 V three-ph + neutral + earth	15	10 365 x 1 785 x 1 500	15/30
PGL12000-2	12 050	2,0	40°	200 mm	400 V three-ph + neutral + earth	15	12 365 x 1 785 x 1 500	15/30
PGL12000-3	12 050	3,0	40°	200 mm	400 V three-ph + neutral + earth	15	12 365 x 1 785 x 1 500	15/30

The folding radius is equal to three times the thickness of the sheet within the maximum capacity of use.
Minimum fold width = 15 times the thickness

* Voltage choice to be specified upon order

Press brakes - PPS



Ref. PPS2050
shown with option
including flanges

Standard equipment

Sturdily constructed, the press brake is equipped with a heavy-duty torsion rod ensuring that the movable sliding block is perfectly parallel while lowering in pressure.

- Collapsible and adjustable work table for high accuracy and durability
- Hydraulic power unit with double safety stops and adjustable pressure
- Metal sheet support up to 500 mm, adjustable for work comfort **1**
- The back gauge, mounted on a slide for pieces of small width, is height-adjustable **2**, the depth is adjustable with a micrometrical screw **3** for high accuracy. The gauge fingers are retractable. **4**
- Numerical control with touchscreen **5** to control axis X and Y (several thousand programs, 80 folds each). Save and create programs, which can also be uploaded by USB stick.
- Quick and easy die turning **6 7**
- Various dies depending on the models (see diagram)
- Punches: 86° radius 0.6 mm **8**, length 550 and/or 800 mm, depending on model
- Safety light curtains located in front: class 4 **9**
- Foot pedal operated **10**
- Power supply 400 V three-phase + neutral

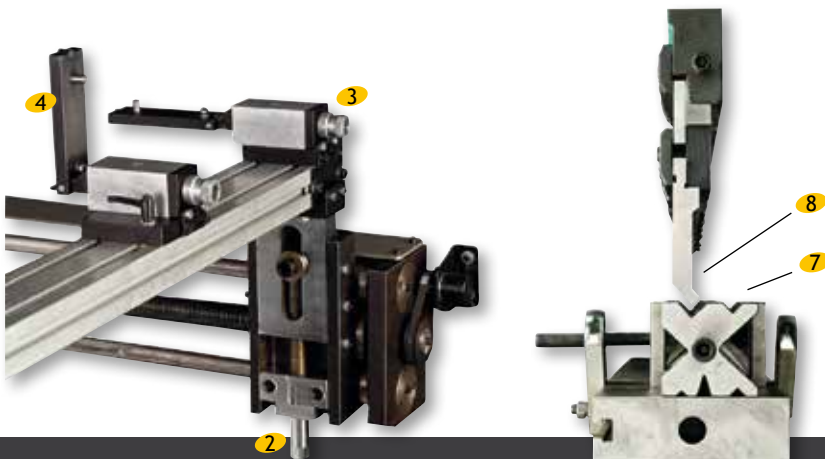

Die details

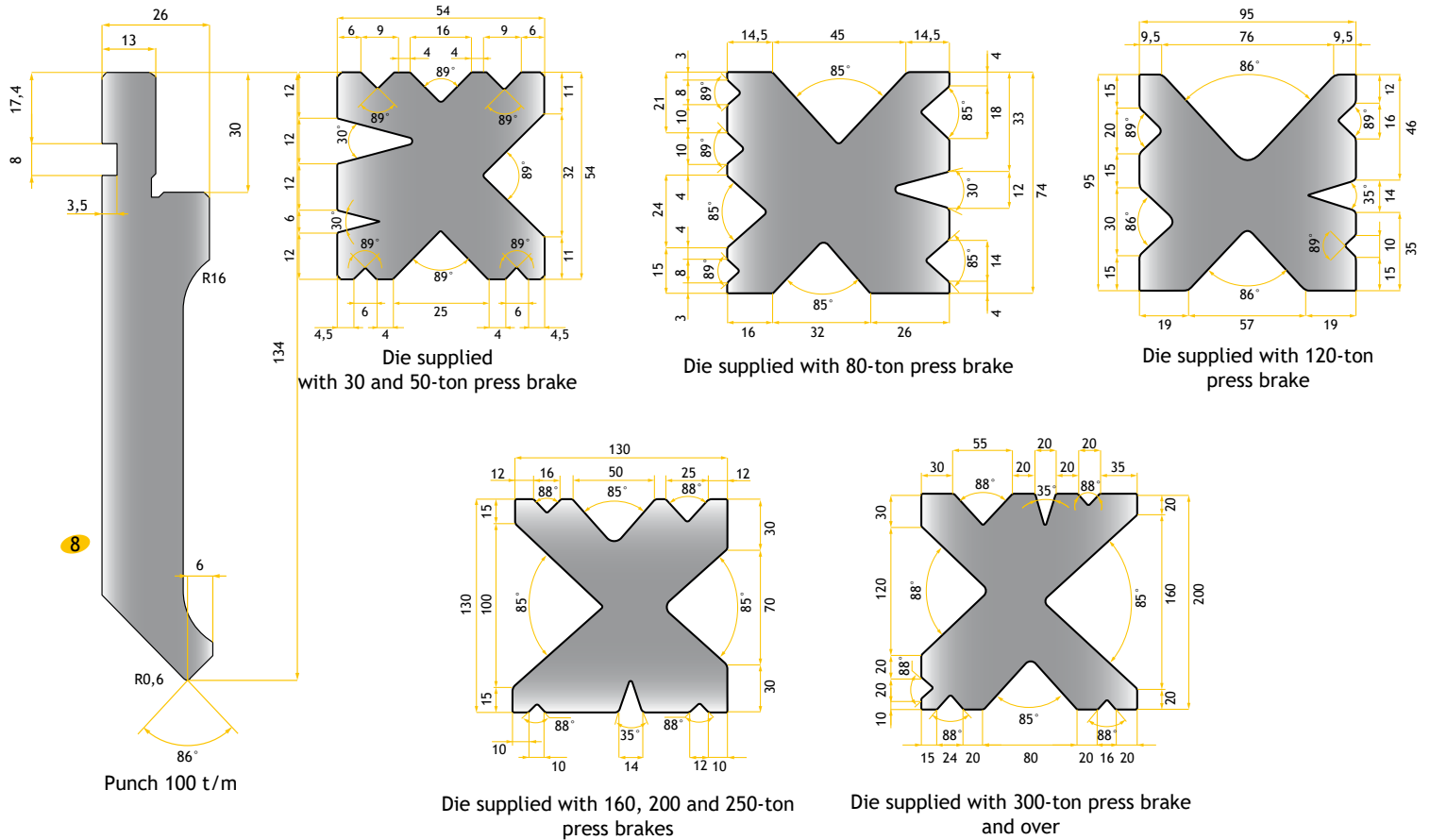

Options

- Table suitable for automatically-centered die, width of 60 mm:
 Length = 1 020 mm: Ref. PPS-T1100B60
 2 100 mm: Ref. PPS-T2100B60
 3 100 mm: Ref. PPS-T3100B60
 4 100 mm: Ref. PPS-T4100B60
- Punch 24° radius 0.5 mm length 550 and/or 800 mm (side view 11), depending on the model
- Segmented punch length 800 mm: segments 100, 10, 15, 20, 40, 50, 200, 265, 100 mm:
 - Ref. POIN-S86-0.6F, Segmented punch: 86° radius 0.6 mm (side view 8)
 - Ref. POIN-S24-0.5F, Segmented punch: 24° radius 0.5 mm (side view 11)

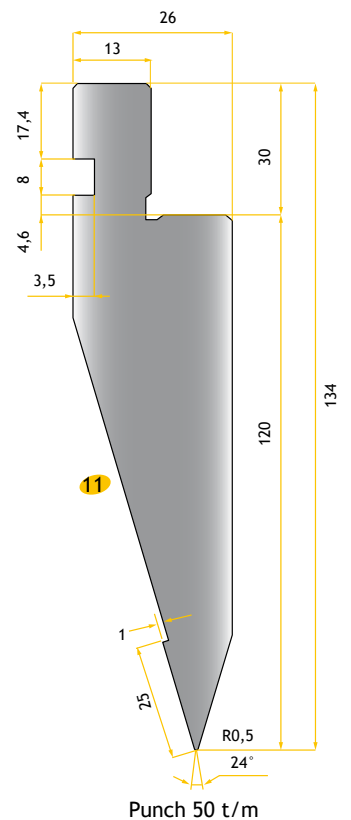
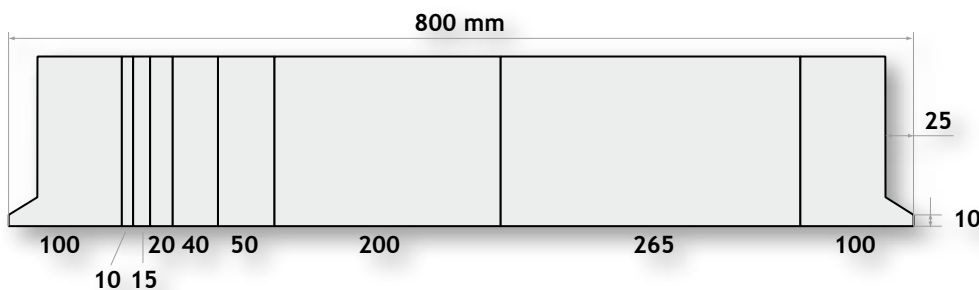
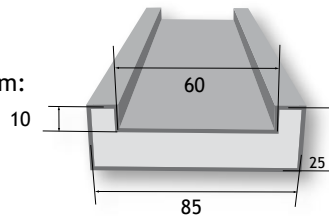

- Table with crowning and position identification, depending on machine length Ref. PPS-BM 12
- Flanges with manual quick tool clamping Ref. PPS-SR 13
- Additional gauge fingers
- Tools and protection devices for fragile materials, such as lacquered sheets
- For further information, please contact us



Manual lever-operated shear - CL

This lever-operated shear is the ideal workshop machine for zinc and thin sheet metal work. The visible blade makes it easy to cut along a traced line. Cut small sizes quickly with the flexible lever.

CL1020-15C

- Adjustable squaring gauge **1**
- Manually retractable sheet clamp with locking system
- Adjustment wheel for rack-and-pinion gauge **2**
- Cut lengths above one meter with successive pushes



Ref. CL1020-15C

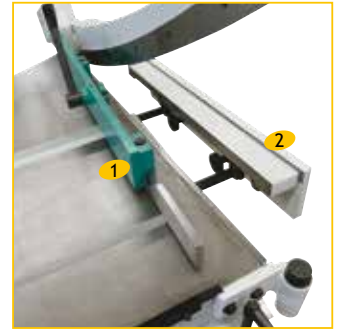

Features	CL1020-15C
Useful cutting length (mm)	1020
Capacity Stainless steel / 1050-H44 aluminum*	0,5-0,8 / 0,4-1,5
Capacity S235JR steel (mm) *	0,4-1,5
Dimensions (mm)	1700 x 1100 x 1150
Table dimensions (mm)	1000 x 700
Weight (kg)	380
Gauge adjustment (mm)	20-500
Squaring gauge (mm)	700
Table height (mm)	780

* min. - max.

Clamping beam with guide rail - TCZ

Clamping beam with guide rail - TCZ **1** for roller shear

Available in 2 lengths

- 2040 mm Ref. TCZ2040A *
- 3040 mm Ref. TCZ3040A
- Clamping device equipped with a leather protective strip for a firm and scratch-free hold

* Fits our workbenches Ref. ETB2040 and ETB2040PVS

Options

- Metal legs - PM **2**
- Roller shear - CCM **3**
 - Handy, robust aluminum body
 - Tempered steel rollers for a longer lifespan
 - Guide rail and 2 grip handles for an accurate cut
 - Capacity zinc 0.8 mm, steel 0.63 mm



Options:
Metal legs and roller shear

Roller shear
Ref. CCM

Manual guillotine shears: CGM2030-10

- 300 mm table with a 650 mm graduated squaring gauge on the left side
- The tabletop is engraved in 10 mm increments for easy measuring
- Back gauge with rack-and-pinion from 15 to 500 mm for perfect parallelism, counter with digital display **1**
- Extendable table front supports large sizes
- Rubber protector on automatic sheet clamping beam for trace-free cutting **2**
- Monobloc blades reversible once
- Controls within reach along the whole length of the machine
- Slanted collecting tray returns cut sheets to the front **3**
- Table height: 880 mm

Features	CGM2030-10
Useful cutting length (mm)	2030
Capacity S235JR steel (mm) *	0,4 - 1,0
Capacity zinc (mm) *	0,4 - 1,2
Dimensions (mm)	2400 x 1360 x 1 250
Weight (kg)	590

* min. - max.



Rack-and-pinion operated back gauge, counter with digital

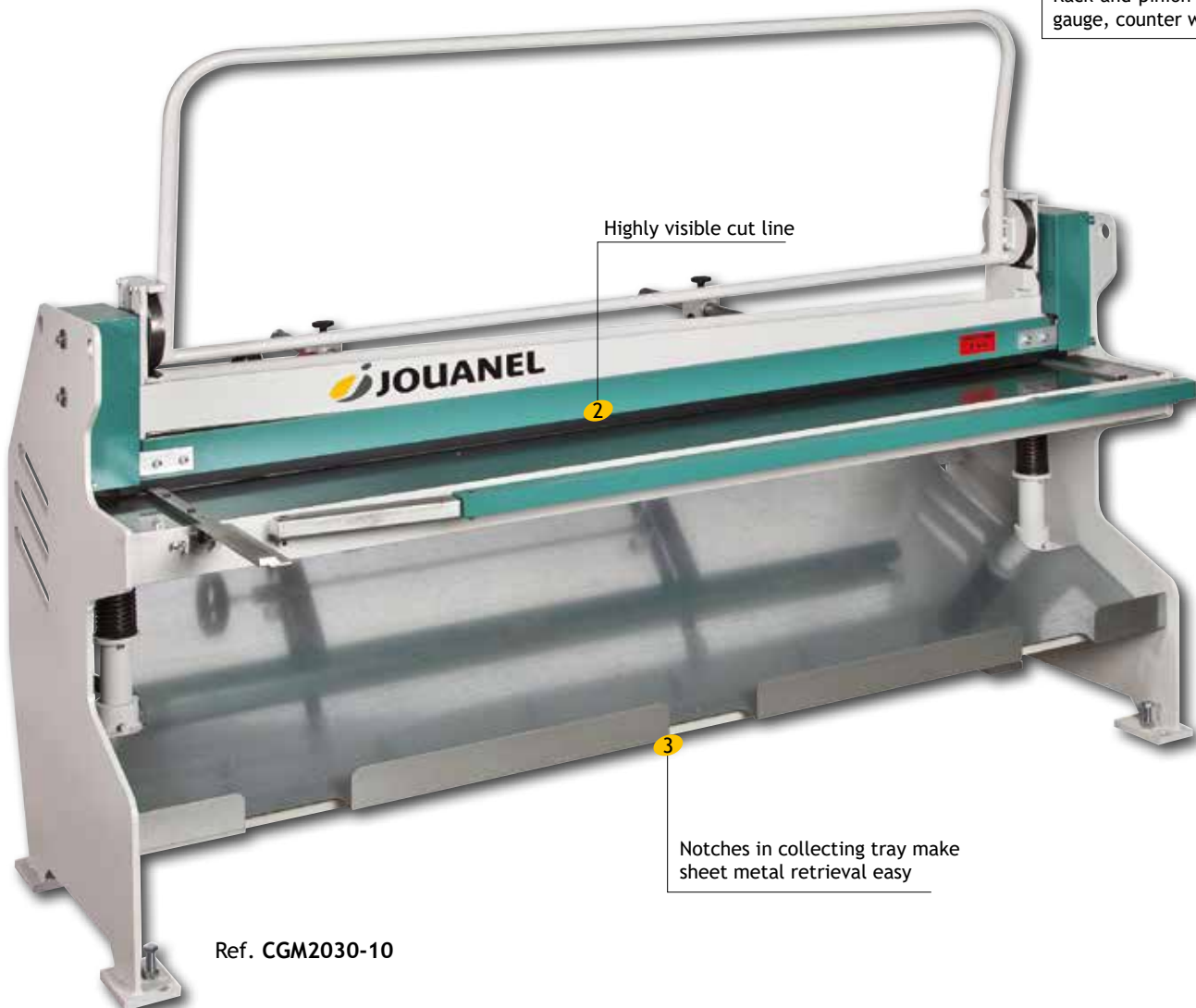

Ref. CGM2030-10

● Manual guillotine shears: CGM1050, CGM2050, CGM2550 and CGM3080 with manual rack-and-pinion back gauge

Machine sizes available: 1 m, 2 m, 2.5 m and 3 m

Simple and accurate, the manually-operated CGM guillotine shears will efficiently meet your workshop cutting requirements for thin sheet metal.

With a cutting accuracy equal to an electric model, this machine will easily find its place in the workshop, without costly installation. Its sturdy, low-maintenance mechanical design makes a sustainable and durable investment. Its flexible and balanced cutting lever make it pleasant to use on a daily basis.



Model shown
Ref. CGM2050 with options

Standard equipment

- The tabletop (300 mm wide **1** x 800 mm high) is engraved in 10 mm increments to simplify cutting without the back gauge
- Extendable table front **2** (+480 mm) supports large sizes
- Extendable back sheet support: 120 mm (excludes Sheet holding plate option)
- Graduated squaring gauge, 500 mm on the left (except for CGM3080: 1000 mm on the left) and 300 mm on the right **3**
- Automatic clamping system
- Monobloc blades reversible once
- 2 lateral lever arms with gear train to cut thicker sheets effortlessly
- Slings rings

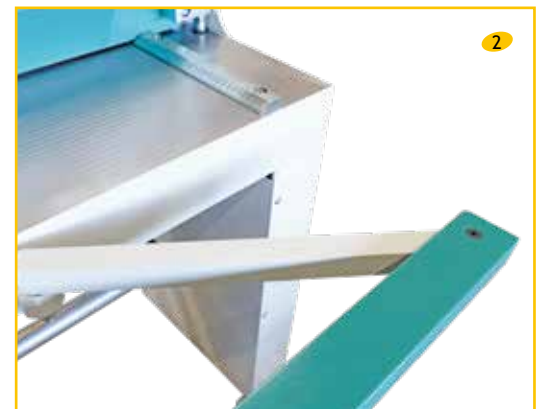

	CGM1050	CGM2050	CGM2550	CGM3080
Useful cutting length (mm)	1050	2050	2550	3080
Capacity S235JR steel (mm) *	0,4 - 1,5	0,4 - 1,0	0,4 - 1,0	0,5 - 1,0
Capacity zinc, copper (mm) *	0,4 - 1,8	0,4 - 1,2	0,4 - 1,2	0,5 - 1,2
Capacity stainless steel (mm) *	0,4 - 0,8	0,4 - 0,6	0,4 - 0,6	0,5 - 0,6
Capacity 1050-H44 aluminum (mm) *	0,4 - 1,8	0,4 - 1,2	0,4 - 1,2	0,5 - 1,2
Blades	Reversible once	Reversible once	Reversible once	Reversible once
Cutting angle	2,8°	1,5°	1,5°	1,5°
Left and right cutting levers (mm)	1100	1100	1100	1100
Graduated squaring gauge, table front, left side (mm)	500	500	500	1000
Graduated squaring gauge, table front, right side (mm)	300	300	300	300
Back gauge range (mm)	15 - 750	15 - 750	15 - 750	15 - 750
Conical adjustment: mechanical counter (mm)	+/- 5	+/- 5	+/- 5	+/- 5
Operating dimensions (l x w x h)(mm)	1550 x 1600 x 1300	2550 x 1600 x 1300	3050 x 1600 x 1300	3550 x 2000 x 1300
Net weight (kg)	433	595	692	790

* min.-max. thickness

• Manual back gauge with rack-and-pinion

- Range from 15 to 750 mm
- Side operated with adjustment wheel located on the right side **4**
- Large digital display indicates back gauge position, accurate to a tenth of a millimeter **5**
- Conical adjustment to slant the back gauge, with a counter **6** (accurate to ± 0.1 mm), and quick alignment adjustment

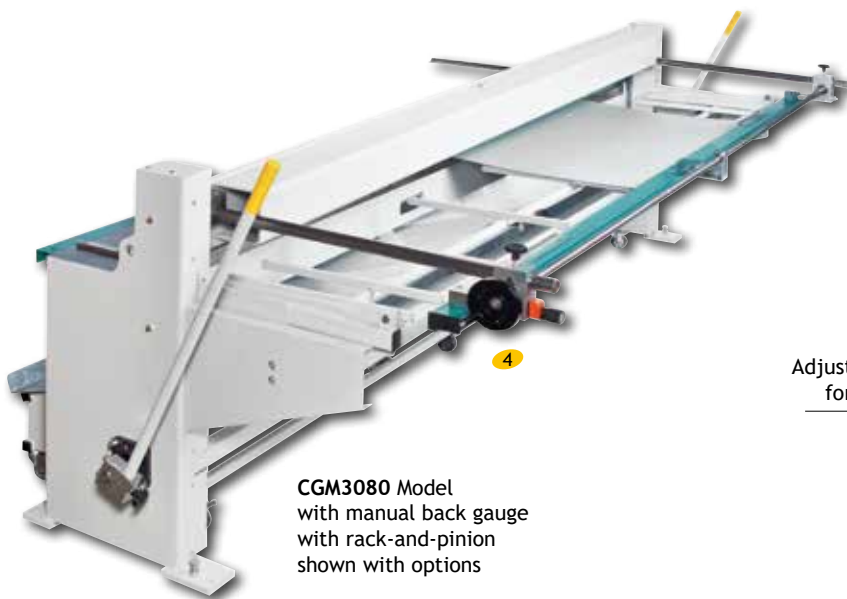

CGM3080 Model with manual back gauge with rack-and-pinion shown with options

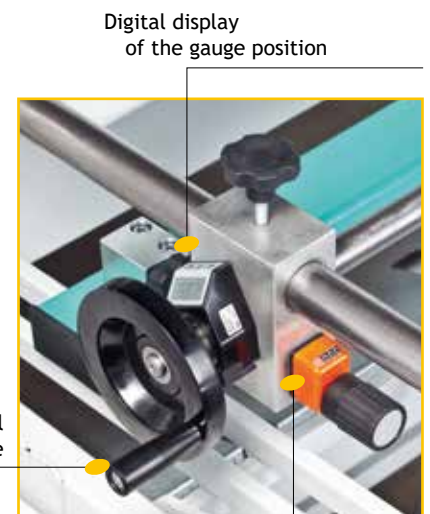

Back gauge conical adjustment



Manual guillotine shears - CGM



Options

- Belt drive manual back gauge with control and display at the front of the machine!
Ref. CGM2050-BCAV, CGM2550-BCAV, CGM3080-BCAV
 - Range from 15 to 750 mm
 - Front operated by adjustment wheel **5**
 - Digital display indicates back gauge position, accurate to a tenth of a millimeter
 - Conical adjustment to slant the back gauge, with a counter **6** (accurate to ± 0.1 mm), and quick alignment adjustment
- Left squaring gauge: 1000 mm (instead of 500 mm)
- Automatic sheet holding plate **7**: Ref. CGM-PEIGNE
- Portable tray, on swivel casters with brakes, collects sheets **8**, with two positions for sheets up to 750 mm wide, Ref. CGM-BL

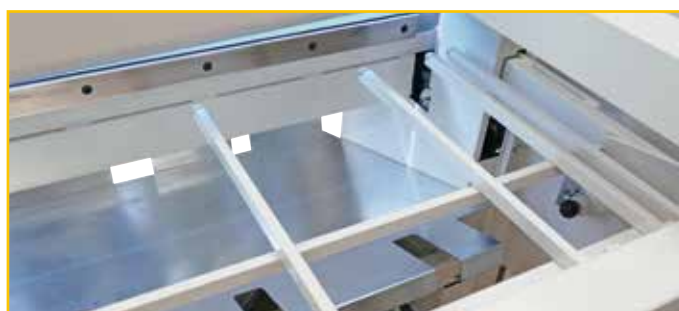
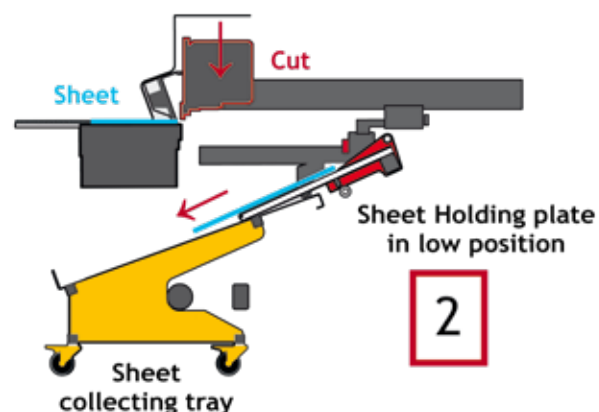
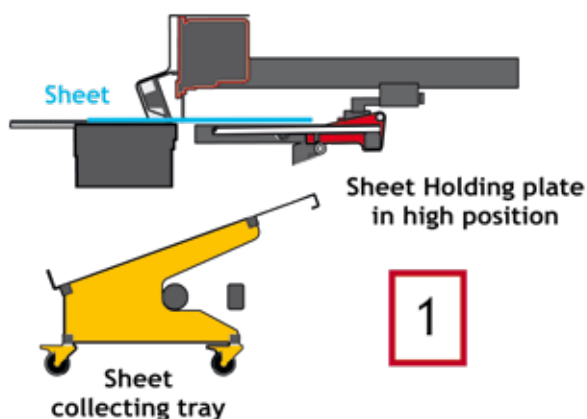
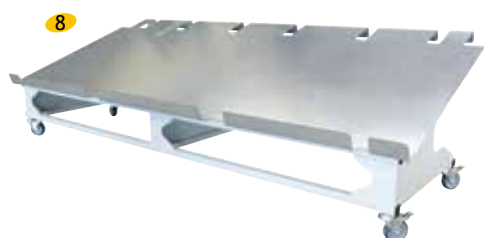

OPTION Features

Automatic sheet holding plate	CGM1050-PEIGNE	CGM2050-PEIGNE	CGM2550-PEIGNE	CGM3080-PEIGNE
Maximum distance between 2 fingers (mm)	330	370	400	495
Minimum distance between 2 fingers (mm)	40	40	40	40
Number of fingers	7	10	11	12
Maximum length of sheets (mm)	750	750	750	750
Sheet collecting tray on casters	CGM1050-BL	CGM2050-BL	CGM2550-BL	CGM3080-BL
Number of casters with brakes	4	4	4	6

● Electric guillotine shears: CGS

The CGS is perfectly designed to meet the business requirements for thin sheet metal work, as well as zinc, metal construction, maintenance, professional education, etc.

Machine sizes available: 1 m, 1.5 m, 2 m, 2.5 m and 3 m

Technical advantages

- Back gauge with rack-and-pinion from 15 to 500 mm, counter with digital display for perfect alignment
- Extendable table front supports large sizes
- Rubber protector on automatic clamping beam for scratch-free cutting
- Slanted collecting tray returns cut sheets to the front
- Foot switch
- Monobloc blades reversible once
- 300 mm table with a 650 mm graduated squaring gauge on the left side
- Engraved tabletop, in 10 mm increments for easy and precise measuring
- Illuminated cut line indicator ①
- Cut counter with reset
- CE Conformity



Features	CGS1030-20	CGS1530-20	CGS2030-15	CGS2530-12	CGS3030-12
Useful cutting length (mm)	1030	1530	2030	2530	3030
Capacity S235JR steel (mm) *	0,4 - 2,5	0,4 - 2,0	0,4 - 1,8	0,4 - 1,2	0,5 - 1,2
Dimensions (mm)	1340 x 1340 1240	1840 x 1340 1240	2370 x 1370 1240	2900 x 1370 1240	3370 x 1370 1240
Weight (kg)	1020	1250	1270	1446	1610
Power (kW)	2,2	2,2	2,2	2,2	2,2
Power supply **	400 V three-ph + neutral + ground	400 V three-ph + neutral + ground	400 V three-ph + neutral + ground	400 V three-ph + neutral + ground	400 V three-ph + neutral + ground
Rate (cuts / min)	26	26	26	26	26

* min.-max. ** Voltage choice to be specified upon order

● Options

- Front operated electric back gauge with 15-500 mm cutting range, adjustable to 1/10 mm, for easy precision cutting, Ref. **CGS-BAS**
- Sheet holding plate: the back gauge, manual or electric, can be equipped with a sheet holding plate for large dimensions and thin sheets, Ref. **CGS-PST** ②



Sheet holding plate

● Electric guillotine shears: CGI2050-BCREM, CGI2550-BCREM and CGI3080-BCREM with manual rack-and-pinion back gauge

Machine sizes available: 2 m, 2.5 m and 3 m

The new generation of electric shears, CGI, meets the quality requirements inherent to the metal building envelope and industrial metal sheet working businesses.

In addition to its modern construction, the CGI was designed and manufactured especially for intensive use, such as batch production. With a sturdy heavy-duty structure, its high output and cutting quality make it one of the most efficient shears on the market today.



Model shown
Ref. CGI3080-BCREM
with options

Standard equipment

- The tabletop (300 mm wide **1** x 800 mm high) is engraved in 10 mm increments to simplify cutting without the back gauge
- Extendable table front **2** (+480 mm) supports large sizes
- Extendable back sheet support: 120 mm (excludes Sheet holding plate option)
- Graduated squaring gauge, 500 mm on the left and 300 mm on the right **3**
- Automatic clamping system
- Foot switch
- Monobloc blades reversible once
- Cut counter with reset
- Safety light curtains provide safe access to the back of the machine **4**
- Powerful LED cut line indicator built into the sheet holding system (permanent lighting, better visibility) **5**
- Slings rings

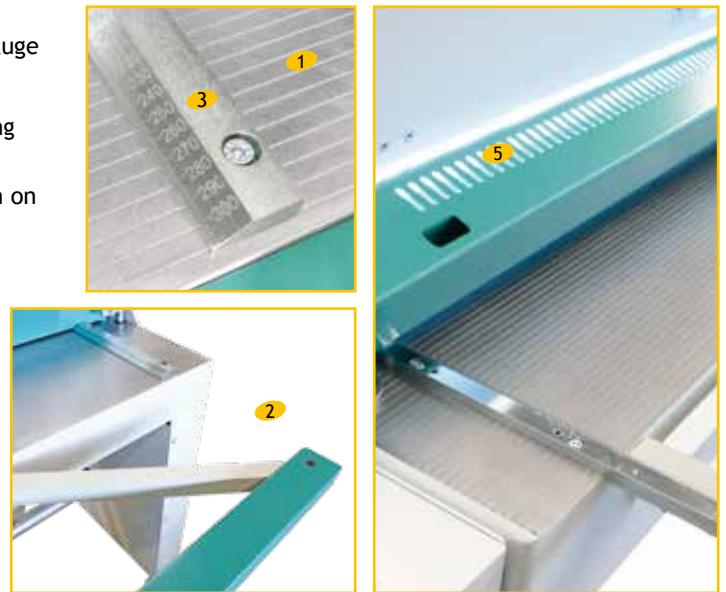

	CGI2050-BCREM	CGI2550-BCREM	CGI3080-BCREM
Useful cutting length (mm)	2 050	2 550	3 080
Capacity S235JR steel (mm)	2	2	1,5
Capacity 1050-H44 aluminum / zinc (mm)	3	3	2
Dimensions (mm)	2720 x 1680 x 1230	3220 x 1680 x 1230	3750 x 1680 x 1230
Weight (kg)	988	1169	1350
Power (kW)	2,2	2,2	2,2
Power supply *(V)	400 V three-ph + ground	400 V three-ph + ground	400 V three-ph + ground
Rate (cuts / min)	25	25	25

* Voltage choice to be specified upon order / 220 V power supply optional

Electric guillotine shears - CGI-BCREM

• Manual rack-and-pinion back gauge

- Range from 15 to 750 mm
- Adjustment wheel on the right side **6**
- Digital display indicates back gauge position, accurate to a tenth of a millimeter
- Conical adjustment to slant the back gauge, with a counter (accurate to ± 0.1 mm) **7**

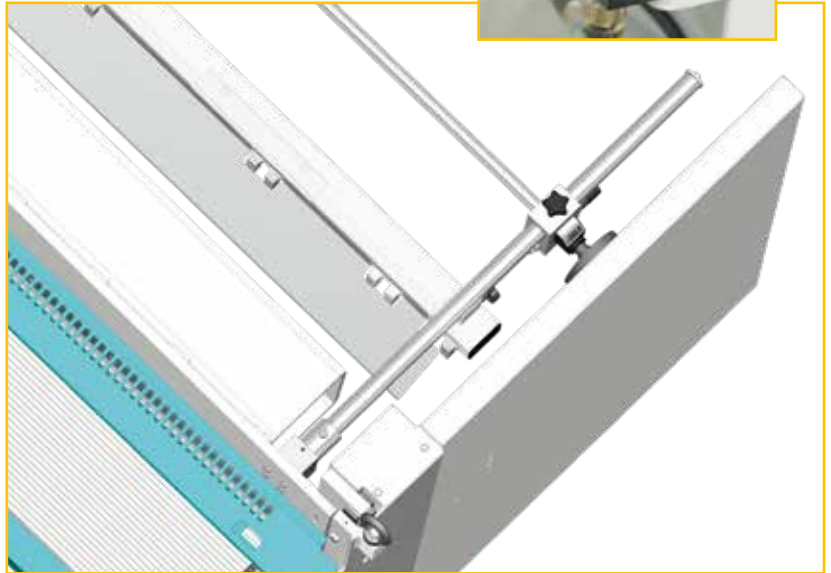
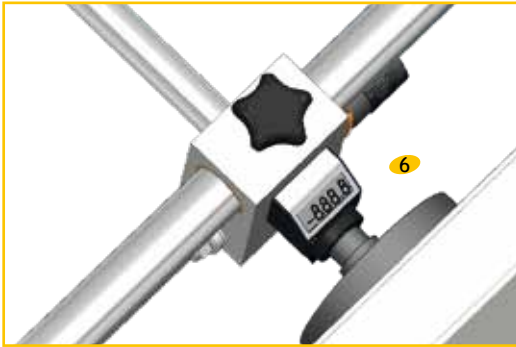

• Options

- Left squaring gauge, 1000 mm (instead of 500 mm)
- Automatic sheet holding plate, Ref. **CGI-PEIGNE**
- Large portable tray, on swivel casters with brakes, collects sheets 8, and has two positions for collecting cut sheets up to 750 mm wide, Ref. **CGM-BL**
- Machine with 220 V power supply (instead of standard 400 V three-phase)

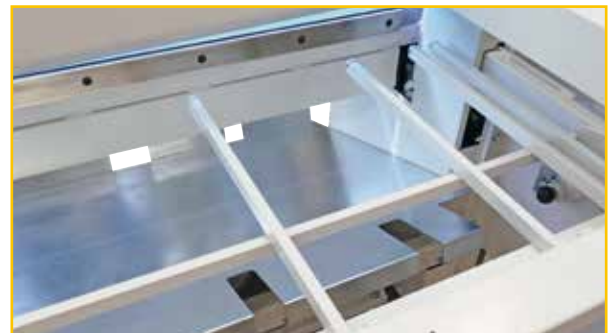

Ref. **CGI-PEIGNE** Sheet holding plate in high position



Ref. **CGI-PEIGNE** Sheet holding plate in low position

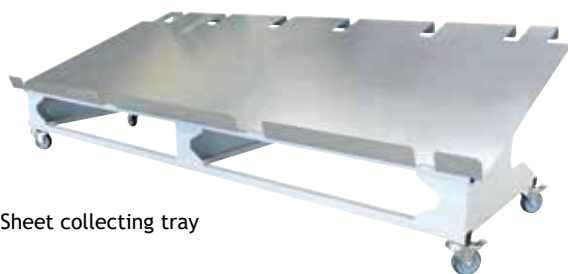

Sheet collecting tray

OPTIONS Features

Automatic sheet holding plate	CGI2050-PEIGNE	CGI2550-PEIGNE	CGI3080-PEIGNE
Maximum distance between 2 fingers (mm)	370	370	495
Minimum distance between 2 fingers (mm)	40	40	40
Number of fingers	10	11	12
Maximum width of sheets (mm)	750	750	750
Sheet collecting tray on casters	CGM2050-BL	CGM2550-BL	CGM3080-BL
Number of casters with brakes	4	4	6

● Electric guillotine shears: CGI2050-BCAV, CGI2550-BCAV, CGI3080-BCAV and CGI4080-BCAV with manual back gauge, belt drive, front-operated

Machine sizes available: 2 m, 2.5 m, 3 m and 4 m

The new generation of electric shears, CGI, meets the quality requirements inherent to the metal building envelope and industrial metal sheet working businesses.

In addition to its modern design, the CGI was designed and manufactured especially for intensive use, such as series production. With a sturdy heavy-duty structure, its high output and cutting quality make it one of the most efficient shears on the market today.

Since the machine is front-operated, working conditions are improved and the additional features simplify handling and cutting large-sized sheet metal.



Model shown
Ref. CGI3080-BCAV
with options

Standard equipment

- The tabletop (300 mm wide **1** x 800 mm high) is engraved in 10 mm increments to simplify cutting without the back gauge
- Extendable table front **2** (+480 mm) supports large sizes
- Extendable back sheet support: 120 mm (excludes Sheet holding plate option)
- Graduated squaring gauge, 500 mm on the left and 300 mm on the right **3**
- Automatic clamping system
- Foot switch
- Monobloc blades reversible once
- Cut counter with reset
- Safety light curtains provide safe access to the back of the machine **4**
- Powerful LED cut line indicator built into the sheet holding system (permanent lighting, better visibility) **5**
- Slings rings

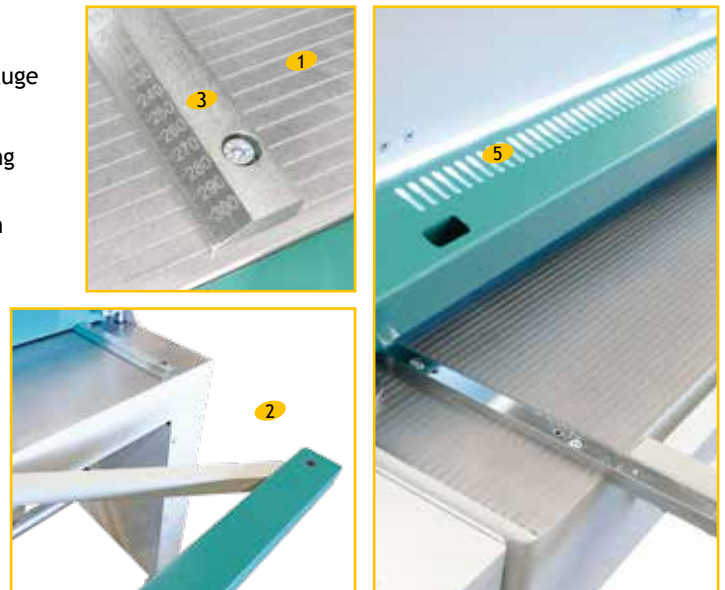

	CGI2050-BCAV	CGI2550-BCAV	CGI3080-BCAV	CGI4080-BCAV
Useful cutting length (mm)	2 050	2 550	3 080	4 080
Capacity S235JR steel (mm)	2	2	1,5	1,2
Capacity 1050-H44 aluminum / zinc (mm)	3	3	2	1,5
Dimensions (mm)	2720 x 1680 x 1230	3220 x 1680 x 1230	3750 x 1680 x 1230	4750 x 1680 x 1230
Weight (kg)	988	1169	1350	1531
Power (kW)	2,2	2,2	2,2	2,2
Power supply *(V)	400 V three-ph + ground	400 V three-ph + ground	400 V three-ph + ground	400 V three-ph + ground
Rate (cuts / min)	25	25	25	25

* Voltage choice to be specified upon order / 220 V power supply optional

Electric guillotine shears - CGI-BCAV

• Manual back gauge with belt drive

- Range from 15 to 750 mm
- Front-operated by adjustment wheel **6**
- Digital display indicates back gauge position, accurate to a tenth of a millimeter
- Conical adjustment to slant the back gauge, with a counter (accurate to ± 0.1 mm) **7**



• Options

- Left squaring gauge, 1000 mm (instead of 500 mm)
- Automatic sheet holding plate, Ref. CGI-PEIGNE
- Large portable tray, on swivel casters with brakes, has two positions for collecting cut sheets up to 750 mm wide, Ref. CGM-BL
- Machine with 220V power supply (instead of standard 400V three-phase)

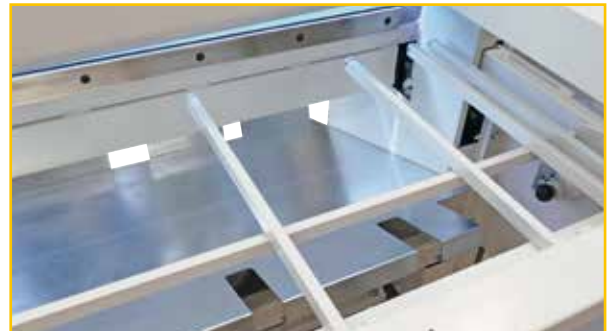

Ref. CGI-PEIGNE Sheet holding plate in high position



Ref. CGI-PEIGNE Sheet holding plate in low position

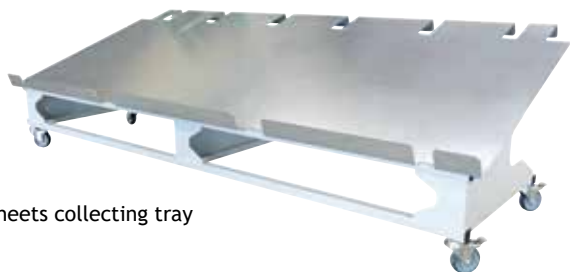

Sheets collecting tray

OPTIONS Features

Automatic sheet holding plate	CGI2050-PEIGNE	CGI2550-PEIGNE	CGI3080-PEIGNE	CGI4080-PEIGNE
Maximum distance between 2 fingers (mm)	370	370	495	495
Minimum distance between 2 fingers (mm)	40	40	40	40
Number of fingers	10	11	12	14
Maximum width of sheets (mm)	750	750	750	750
Sheet collecting tray on casters	CGM2050-BL	CGM2550-BL	CGM3080-BL	CGI4080-BL
Number of casters with brakes	4	4	6	8

• Electric guillotine shears: CGI2050-BAE, CGI2550-BAE, CGI3080-BAE and CGI4080-BAE with electric back gauge, front-operated

Machine sizes available: 2 m, 2.5 m, 3 m and 4 m

The new generation of electric shears, CGI, meets the quality requirements inherent to the metal building envelope and industrial metal sheet working businesses.

In addition to its modern design, the CGI was designed and manufactured especially for intensive use, such as series production.

Its sturdy and practical design, as well as its excellent cutting quality, come from more than 70 years of experience in the shearing business. Developed by Jouanel Industrie, the multiple functions of the numerical control make it one of the most productive shears on the market today



DEMONSTRATION VIDEO
available on YouTube® / Channel
"Jouanel Industrie"



Model shown
Ref. CGI3080-BAE
avec options

Standard equipment

- The tabletop (300 mm wide **1** x 800 mm high) is engraved in 10 mm increments to simplify cutting without the back gauge
- Extendable table front **2** (+480 mm) supports large sizes
- Extendable back sheet support: 120 mm (excludes Sheet holding plate option)
- Graduated squaring gauge, 500 mm on the left and 300 mm on the right **3**
- Automatic clamping system
- Foot switch
- Monobloc blades reversible once
- Cut counter with reset, for daily or cumulative total of cuts completed
- Safety light curtains provide safe access to the back of the machine **4**
- Powerful LED cut line indicator built into the sheet holding system (permanent lighting, better visibility) **5**
- Slings rings

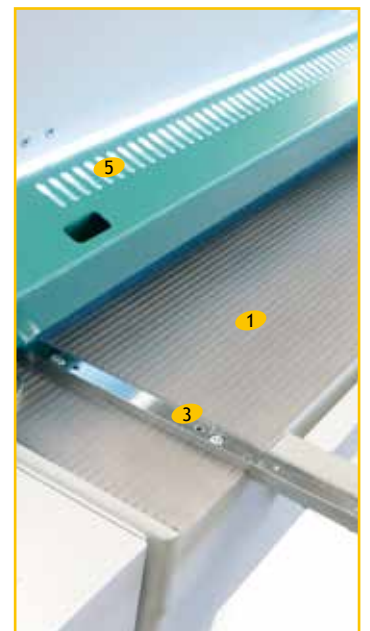

	CGI2050-BAE	CGI2550-BAE	CGI3080-BAE	CGI4080-BAE
Useful cutting length (mm)	2 050	2 550	3 080	4 080
Capacity S235JR steel (mm)	2	2	1,5	1,2
Capacity 1050-H44 aluminum / zinc (mm)	3	3	2	2
Dimensions (mm)	2720 x 1680 x 1460	3220 x 1680 x 1460	3750 x 1680 x 1460	4750 x 1680 x 1460
Weight (kg)	988	1169	1350	1531
Power (kW)	2,2	2,2	2,2	2,2
Power supply *(V)	400 V three-ph + neutral + ground	400 V three-ph + neutral + ground	400 V three-ph + neutral + ground	400 V three-ph + neutral + ground
Rate (cuts / min)	25	25	25	25

* Voltage choice to be specified upon order / 220 V power supply also an option

Electric guillotine shears - CGI-BAE

• Electric back gauge

- Range from 19 to 750 mm
- Conical adjustment to slant the back gauge, with a counter (accurate to ± 0.1 mm) **6**
- Back gauge with numerical control

• Numerical control with 7"-16:9 color touchscreen

- Program several lengths and quantities
- Cutting length adjustment, to increase the cutting rate of small parts
- Maintenance menu informs the operator of preventative maintenance needed, depending on the cumulative cut count
- Remote assistance available from our factory via Internet
- Cut counter with reset, for daily or cumulative total of cuts completed
- Password protection locks machine, with several levels of access (operator, maintenance, administrator)

Operator selection:

- Manual mode: 1 back gauge movement, several cuts
- Program mode: each program can be named, saved, and contains several back gauge movements and several cuts which will automatically follow one another during production
- Automatic mode: run program, which were previously created in the program menu.

• Options

- Left squaring gauge, 1000 mm (instead of 500 mm)
- Automatic sheet holding plate, Ref. CGI-PEIGNE
- Large portable tray, on swivel casters with brakes, has two positions for collecting cut sheets up to 750 mm wide, Ref. CGM-BL (excludes 4-meter model, Ref. CGI4080-BL)
- Machine with 220V power supply (instead of standard 400V three-phase)



Numerical control screen display "Menu Auto"



Numerical control screen display "Manual mode"



Ref. CGI-PEIGNE
Sheet holding plate in high position



Ref. CGI-PEIGNE
Sheet holding plate in low position

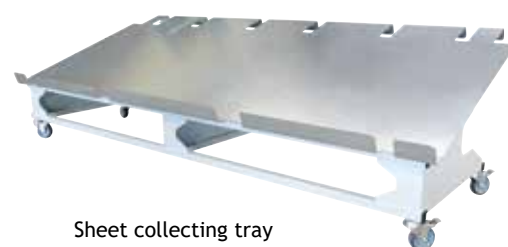

Sheet collecting tray

OPTIONS Features

Automatic sheet holding plate	CGI2050-PEIGNE	CGI2550-PEIGNE	CGI3080-PEIGNE	CGI4080-PEIGNE
Maximum distance between 2 fingers (mm)	370	370	495	495
Minimum distance between 2 fingers (mm)	40	40	40	40
Number of fingers	10	11	12	14
Maximum width of sheets (mm)	750	750	750	750
Sheet collecting tray on casters	CGM2050-BL	CGM2550-BL	CGM3080-BL	CGI4080-BL
Number of casters with brakes	4	4	6	8

Hydraulic guillotine shears - CHS

With capacities from 0.6 to 16 mm and lengths from 2 to 4 meters, CHS shears are suitable for all sorts of applications: roofing, cladding, metal construction, locksmithing, metalwork, tinsmithing, HVAC...

Machines available from 2 m to 4 m

Hydraulic guillotine shears: CHS with numerical control

- Manual adjustment of blade gap on the side of the machine
- Electric back gauge from 20 to 900 or 1000 mm (depending on model), retractable at the end of the stroke
- Hardened steel blades with 4 cutting edges
- Self-adjusting gauge for each cut
- Program adjusts speed automatically acc. to scheduled motion
- Cut counter with reset, for daily or cumulative total of cuts completed
- Large program capacity - 10 sequences per program (back gauge and number of parts)
- Manual mode selection possible
- Numerical control with 7"-16:9 color touchscreen
- Hour counter for routine machine maintenance follow-up
- Operator and maintenance access codes
- Continuous cut with programmable pauses
- Powerful built-in LED cut line indicator
- Cutting length adjustment on touchscreen
- Safety light curtains provide safe access to the back of the machine **1**

- 1m front squaring gauge includes graduated tool, T-shaped slot with retractable mechanism for easy sheet metal insertion **2**
- Front support arms **3**
- Ball transfer table **4**
- Grill with hand wells for narrow strips **5**
- CE Conformity
- Remote assistance (First time use, updates, diagnostic)

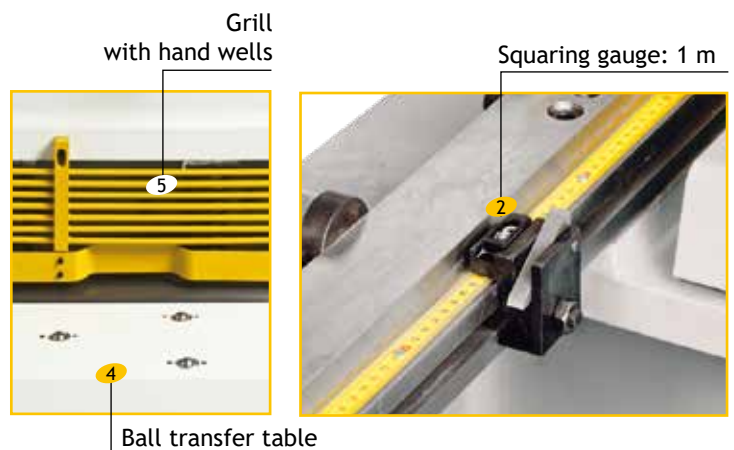

Options

- Automatic electric adjustment of blade gap according to selected thickness - Ref. CHS-RAEL **6**
- Pneumatic sheet holding plate **7** to be specified upon order - Ref. CHS-PST *This option requires a compressed air supply*
- Variable angle gauge **8** - Ref. CHS-EQC



7 Pneumatic sheet holding plate



8 Variable angle gauge

Hydraulic guillotine shears - CHS

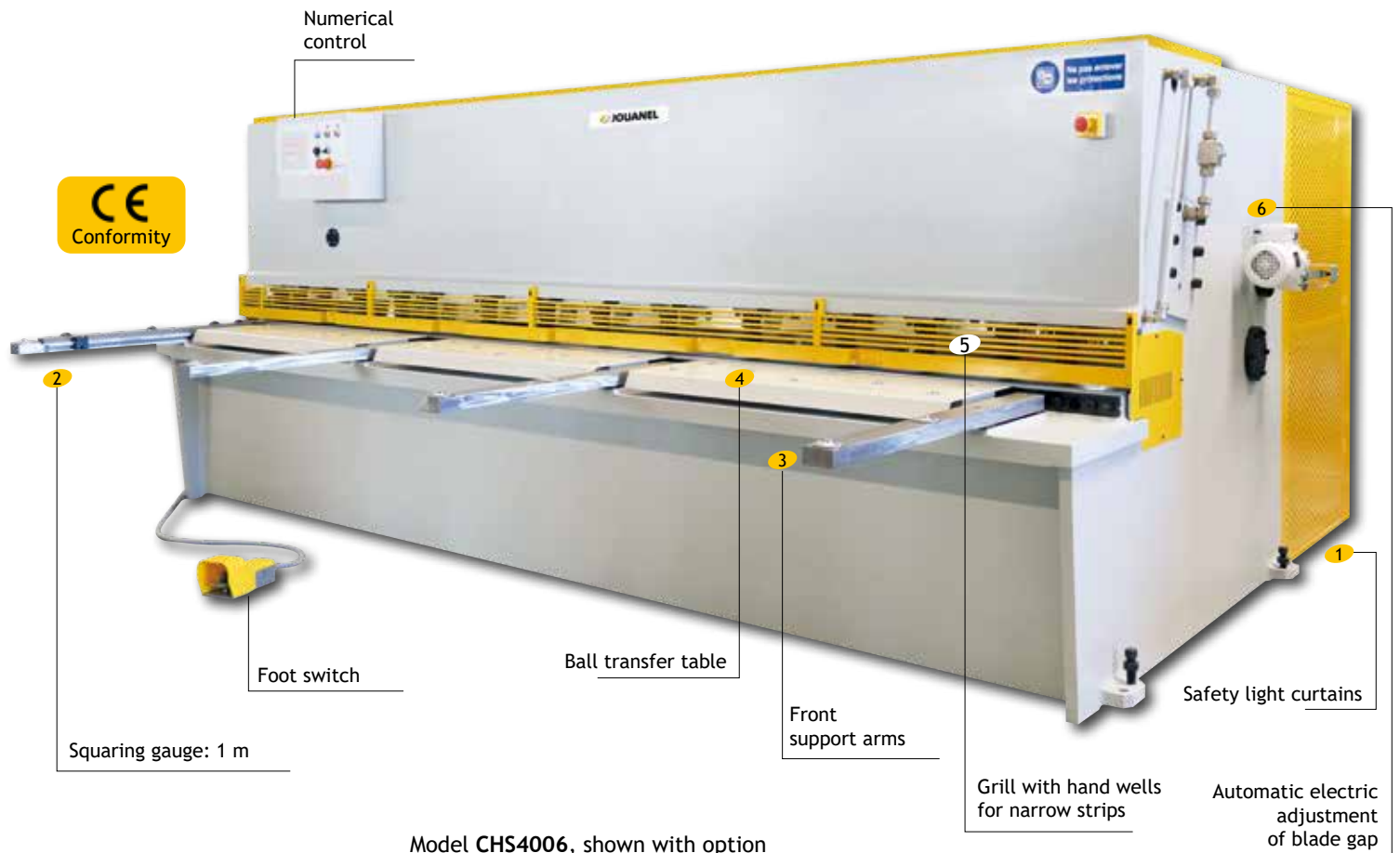

Model CHS4006, shown with option automatic electric adjustment of the blades clearance (Ref. CHS-RAEL)

Features	CHS 2004	CHS 2504	CHS 2506	CHS 2508	CHS 2512	CHS 2516	CHS 3204	CHS 3206	CHS 3208	CHS 3212	CHS 3216	CHS 4006	CHS 4008	CHS 4012
Useful cutting length (m)	2,0	2,5	2,5	2,5	2,5	2,5	3,2	3,2	3,2	3,2	3,2	4,0	4,0	4,0
Capacity S235JR steel (mm)*	0,6 - 4	0,6 - 4	0,6 - 6	0,8 - 8	0,8 - 12	1 - 16	0,6 - 4	0,6 - 6	0,8 - 8	0,8 - 12	1 - 16	0,6 - 6	0,8 - 8	1 - 12
Number of front support arms	2	2	2	2	2	2	3	3	3	3	3	4	4	4
Dimensions with back gauge and grill (mm) **	L 2560 I 2400 h 1450	3 110 2 400 1 450	3 130 2 530 1 600	3148 2850 1760	3 225 2 800 1 940	3 225 2 800 1 940	3 840 2 675 1 620	3 840 2 675 1 620	3 848 2 850 1 750	3 925 2 800 1 940	3 925 2 800 1 940	4 630 2 850 1 700	4 650 2 900 1 760	4 725 3 000 2 040
Weight (kg)***	3 000	3 400	5 200	7000	8 600	11 800	5 100	6 700	8 300	10 800	13 800	8 600	9 700	13 200
Power (kW)	4,5	4,5	8	11,5	19	22,5	6	8	11,5	19	22,5	8	11,5	19
Rate (cuts/min)	20	20	18	16	16	14	20	14	14	12	10	14	12	10
Table height (mm)	735	735	800	800	800	800	800	800	800	800	800	800	800	800
Power supply****	400 V + three-ph + neutral + ground	400 V + three-ph + neutral + ground	400 V + three-ph + neutral + ground	400 V + three-ph + neutral + ground	400 V + three-ph + neutral + ground	400 V + three-ph + neutral + ground	400 V + three-ph + neutral + ground	400 V + three-ph + neutral + ground	400 V + three-ph + neutral + ground	400 V + three-ph + neutral + ground	400 V + three-ph + neutral + ground	400 V + three-ph + neutral + ground	400 V + three-ph + neutral + ground	400 V + three-ph + neutral + ground
Cutting angle	1,5°	1,5°	1,5°	1,5°	1,5°	1,5°	1,5°	1,5°	1,5°	1,5°	1,5°	1,5°	1,5°	1,5°
Handling balls on table	16	16	16	16	16	16	24	24	24	16	24	24	24	24
Back gauge min. - max. (mm)*	20-900	20-900	20-1000	20-1000	20-1000	20-1000	20-900	20-1000	20-1000	20-1000	20-1000	20-1000	20-1000	20-1000

* Min. - Max.

** Space requirements for transport, without squaring gauge (length: 700 mm)

*** Without oil

**** Voltage choice to be specified upon order

Electric beading machines: BAGPRO2, BAGPRO3, BAGPRO4

Electronic winding control timer and reset allows the operator to precisely adjust bead opening and make perfectly identical products in repetitive manufacturing.

Machine sizes available: 2,04 m - 3,04 m - 4 m



Model shown
Ref. BAGPRO2



Standard equipment

- Supplementary device **1**, for bending directly on the machine (except for Ref. **BAGPRO4**)
- Adjustable electronic timer for winding
- Standard machine includes one rod: Ø12, 14, 16 or 18 mm for Ref. **BAGPRO2** (please specify Ø upon order), Ø16 or 18 mm for Ref. **BAGPRO3** (please specify Ø upon order) and Ø18 mm for Ref. **BAGPRO4**
- Front work table
- Foot control pedal keeps hands free



Lateral opening allows for bead removal without withdrawing the rod

Technical advantages

- Speed
- Ease-of-use / Convenient
- Production regularity
- Quick adjustments
- **Lateral opening allows for bead removal without withdrawing the rod **2****

Available in 6 meters:
please contact us

Features	BAGPRO2	BAGPRO3	BAGPRO4
Useful length (mm)	2040	3040	4000
Dimensions (mm)	2 600 x 1 100 x 1 120	3 600 x 1 100 x 1 120	4 500 x 1 100 x 1 120
Power supply (V)	220 single-phase	220 single-phase	220 single-phase
Power (kW)	0,75	0,75	0,75
Standard Øs of rods:	12, 14, 16 or 18	16 or 18	18
Other rod Øs available (optional):	20, 24, 28	20, 24, 28	20, 24
Weight (kg)	310	465	620

Capacity of electric beading machines in mm

Capacity (mm)	Ø12	Ø14	Ø16	Ø18 and +
Useful length	2040	2040	2040 3040	2040 3040 4000
Zinc / Copper	0,65	0,8	0,8 0,65	0,8 0,8 0,8
Stainless steel	0,4	0,4	0,5 0,4	0,5 0,5 0,5
Lacquered / Galvanized steel	0,5	0,63	0,7 0,53	0,75 0,63 0,63

Options

- Other rod Øs (see table)
- Set of 4 wheels: Ref. **PCXR3040**

Manual beading machines - BAGMP, BAGMD

Manual beading machines: BAG2040MP, BAG3030MP

Machine sizes available: 2,04 m - 3,04 m

- The gear train allows you to work alone **1**
- Standard machine includes one rod: 12, 14, 16 or 18 mm Ø for Ref. BAG2040MP (please specify Ø upon order), 16 or 18 mm Ø for Ref. BAG3030MP (please specify Ø upon order)
- Folding device **2**
- Driving mechanism with two cogwheels provide beading regularity **3**



Model shown
Ref. BAG2040MP

Options

- Other rod Øs (see table)

Features	BAG2040MP	BAG3030MP
Useful length (mm)	2040	3040
Dimensions (mm)	2 400 x 700 x 1 300	3 400 x 800 x 1 300
Other standard rod Øs	12, 14, 16 or 18	16 or 18
Other rod Øs available (optional)	20, 24, 28	20, 24
Weight (kg)	120	220

Capacity of manual beading machines (in mm)

Capacity (mm)	Ø12	Ø14	Ø16		Ø18 and +	
Length	2040	2040	2040	3040	2040	3040
Zinc / Copper	0,65	0,8	0,8	0,65	0,8	0,8
Stainless steel	0,4	0,4	0,5	0,4	0,5	0,5
Lacquered / Galvanized steel	0,5	0,63	0,7	0,53	0,75	0,63

Manual beading machine BAG1020MD

Machine size available: 1,02 m

- Standard machine includes gear train and one rod: 12, 14, 16 or 18 mm Ø (please specify Ø upon order)
- Other rod Øs available (optional): 20 and 22 mm

Options

- A set of legs in case the machine cannot be installed on a workbench Ref. PM **4**
- Rods: Ref. BAG12-1020MD, BAH14-1020, BAH16-1020, BAH18-1020, BAG20-1020MD, BAG22-1020MD



Capacity of manual beading machine (in mm)

Capacity (mm)	Ø12	Ø14	Ø16	Ø18 and +
Length	1020	1020	1020	1020
Zinc / Copper	0,65	0,8	0,8	0,8
Stainless steel	0,4	0,4	0,5	0,5
Lacquered / Galvanized steel	0,5	0,63	0,7	0,75

Ref. BAG1020MD
with optional legs

Swaging machines - SB



Swaging machine: SB3

Ideal for the building site, equipped with a large adjustable apron, to be fixed on a workbench or used with its scaffolding attachment.

Swaging machines: SB5 - SB7

New range of swaging machines with welded-metal structure. Shaft made of treatable steel equipped with a large throat, thanks to its lower shaft integrated in a sheath.



Ref. SB3M equipped with scaffolding attachment (as standard on SB3M, min-max Ø: 45-49 mm)



Ref. SB3M on workbench base (as standard on SB3M)



Ref. SB5M without option



Ref. SB5M on base (optional)

Features	SB3M	SB3M-PLUS	SB5M	SB5M-PLUS	SB5E2V2S	SB5E2V2S-PLUS	SB5E2V2S-PLUS	SB5E2V2S-PLUS	SB5E2V2S-PLUS	SB7R	SB7RVV
Capacity Stainless steel / Alu (mm)	0,6 / 0,8	0,6 / 0,8	0,8 / 1,5	0,8 / 1,5	0,8 / 1,5	0,8 / 1,5	0,8 / 1,5	0,8 / 1,5	0,8 / 1,5	1,2 / 2,5	1,2 / 2,5
Capacity S235JR steel (mm)	0,8	0,8	1,2	1,2	1,2	1,2	1,2	1,2	1,2	2,0	2,0
Upper shaft horizontal adjustment	no	no	yes	yes	yes	yes	yes	yes	yes	yes	yes
Ø rolls (mm)	48	48	58	58	58	58	58	58	58	88	88
Rolls reaming Ø (mm)	18	18	24	24	24	24	24	24	24	30	30
Throat depth (mm)	70	70	200	200	200	200	200	200	200	260	260
Weight (kg)	9	9	34	34	72	72	72	72	72	175	175
Power supply	manual	manual	manual	manual	220V 1-ph	220V 1-ph	220V 1-ph	220V 1-ph	220V 1-ph	400V 3-ph	220V 1-ph
Rotation speed	-	-	-	-	Variable**	Variable**	Variable*	Variable*	Variable*	1 fixed	Variable*
Foot-operated control	-	-	-	-	Double	Double	Simple*	Simple*	Simple*	Double	Simple*
Back-forward control	-	-	-	-	foot control	foot control	Switch	Switch	Switch	foot control	Switch
Scaffolding attachment	Included	Included	-	-	-	-	-	-	-	-	-
Workbench base	Included 1	Included	-	-	-	-	-	-	-	-	-
Base	Option 2	Option	Option	Option	Included	Included	Included	Included	Included	Included Single-piece	Included Single-piece
Double apron	Included	Included	Option 3	Option	Option 4	Option	Option 5	Option	Option	- 6	-
Sets of rolls	Extra (n° 1, 3, 4, 5, 13, 6, 7, 22-22, 23, 24, 25, 26, 28)	Included n° 3, 4, 5, 22-22, 24 and 26 Extra (n° 1, 13, 6, 7, 23, 25, 28)	Extra (n° 1, 3, 4, 5, 13, 6, 7, 22-22, 23, 24, 25, 26, 26-50, 28, 32, 36)	Included n° 3, 4, 5, 22-22, 24 and 26 Extra (n° 1, 13, 6, 7, 23, 25, 26-50, 28, 32, 36)	Extra (n° 1, 3, 4, 5, 13, 6, 7, 22-22, 23, 24, 25, 26, 26-50, 28, 32, 36)	Included n° 3, 4, 5, 22-22, 24 and 26 Extra (n° 1, 13, 6, 7, 23, 25, 26-50, 28, 32, 36)	Extra (n° 1, 3, 4, 5, 13, 6, 7, 22-22, 23, 24, 25, 26, 26-50, 28, 32, 36)	Extra (n° 1, 3, 4, 5, 13, 6, 7, 22-22, 23, 24, 25, 26, 26-50, 28, 32, 36)	Included n° 3, 4, 5, 22-22, 24 and 26 Extra (n° 1, 13, 6, 7, 23, 25, 26-50, 28, 32, 36)	Extra (n° 1, 3, 4, 5, 13, 6, 7, 22-22, 23, 24, 25, 26, 26-50, 28, 36)	Extra (n° 1, 3, 4, 5, 13, 6, 7, 22-22, 23, 24, 25, 26, 26-50, 28, 36)

* Variable speed with pedal ** Pl. contact us



Ref. SB5_TAB2
Option Double Apron
(Only on SB5)



Ref. SB5E2V2S
(Base Included)



Ref. SB5E2V2S
(Base Included)



Ref. SB7R
(base included single-piece)

Sets of rolls SBMOL for swaging machines - SB

● Extra available rolls

N° 1

3 mm 5 mm 10 mm 8 mm

N° 3 **4** **5** **13**

N° 22-22

N° 6

N° 7

N° 22-22

N° 23

5 mm 7 mm

N° 24 **25**

N° 26

30 mm 50 mm

N° 26-50
Extra, only on SB5 and SB7

N° 28

N° 32
Extra, only on SB5

6 mm

N° 36 Extra, only on SB5 and SB7

Special roll-forming machines - technical description

- Zinc / 1050-H44 aluminum: 0,6 to 0,8 mm (to be specified with the order)
- Tempered steel rollers
- Forward / backward control
- Forward / backward motion step by step
- Continuous forward motion in automatic mode
- Power supply 380 V three-phased
- Speed: 15 m / min



Round edge and gutter line forming



Round edge and hem forming

Round edge roll-formers: PRBO

- Adjustment range: from 150 to 1000 mm infeed width, depending on the models
- Outer Ø of round edge: 14 mm Ref. **PRBO14**, 16 mm Ref. **PRBO16**, 18 mm Ref. **PRBO18**
- Dimensions 3000 x 1000 x 1100, weight 700 kg Ref. **PRBO14** and **PRBO16**
- Dimensions 3700 x 1500 x 1100, weight 1000 kg Ref. **PRBO18**
- Adjustable entry guide
- Option: Guide for double round edge forming Ref. **PRBO-GFDB**

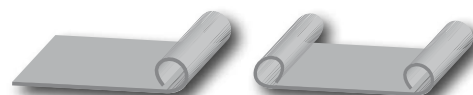

Round edge and hem roll-formers: PRBO-PIN

- Adjustment range: from 200 to 650 mm infeed width, depending on the models
- Outer Ø of round edge: 14 mm Ref. **PRBO14-PIN**, 16 mm Ref. **PRBO16-PIN**, 18 mm Ref. **PRBO18-PIN**
- Dimensions 3000 x 1000 x 1100, weight 1000 kg Ref. **PRBO14-PIN** and **PRBO16-PIN**
- Dimensions 3700 x 1500 x 1100, weight 1300 kg Ref. **PRBO18-PIN** (please contact us)
- Adjustable entry guide
- Width of the hem opposite side: 15 mm, 180° (position of the hem to be specified with the order)

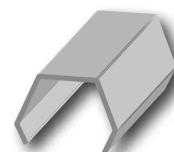
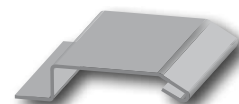

Gutter line roll-former: PRBS100

- Infeed width: 100 mm
- Dimensions 2400 x 700 x 1100 mm, weight 500 kg
- Option: set of slitting cutters at the entry (please contact us)

Buttstrip roll-formers for cleat roofing tray

- Infeed width: 100, 120, 140 or 160 mm
- Dimensions 2400 x 700 x 1100 mm, weight 500 kg

Flat slide roll-formers

- Infeed width: 80 mm, other widths, please contact us
- Option set of slitting cutters at the entry, please contact us



Model shown
Ref. **PRBO14-BS100-C1000**



Possibility to combine two or three different profiles on a same machine, please contact us

● Roll-forming machines: PBC650

The roll-forming machine Ref. **PBC650** is perfectly suitable for shaping cleat roofing trays, available in manual or electric version it can be used in workshop or on building site.

- Light and foldable for an easy handling and a better storage
- Adjustable working height from 160 to 670 mm
- Quick adjustment without tool
- Handling handles **1**
- Drive by rubber rollers **2**
- Pre-set positions of measurements: 35, 40, 45 mm **3**
- Adjustable entry guide up to 650 mm **4**
- Rail **5** for adaptation of roller shear Ref. **CCM 6**



Ref. **PBC650M**
Manual model shown with roller shear
Ref. **CCM** in option



Ref. **PBC650E**
Electric model shown with two-wheeled decoiler
Ref. **DVD1000** (not supplied) and roller shear
Ref. **CCM** in option

● Options

- Roller shear Ref. **CCM 6**

For other options for profiling cleat roofing trays, see p.55, **PROBAC-CPRO** Options.

Features	PBC650M	PBC650E
Gross weight (kg)	66	82
Speed (m/min)	--	10
Dimensions legs excluded (mm)	1115 x 800 x 400	1300 x 800 x 400
Power supply	--	220 V single-phase
Power (kW)	--	0,37
Capacity (mm)	Zinc, Copper, 1050-H44 aluminum: 0,8	
Working height (mm)	160 to 670	160 to 670

Electric roll-forming machines for standing seam PROBAC BA, HT, HT-CE



Specially designed to make the profile type 1 in parallel or conical trays, in workshop or on building site

● Electric roll-forming machine: PROBAC-BA



Manual transversal cut

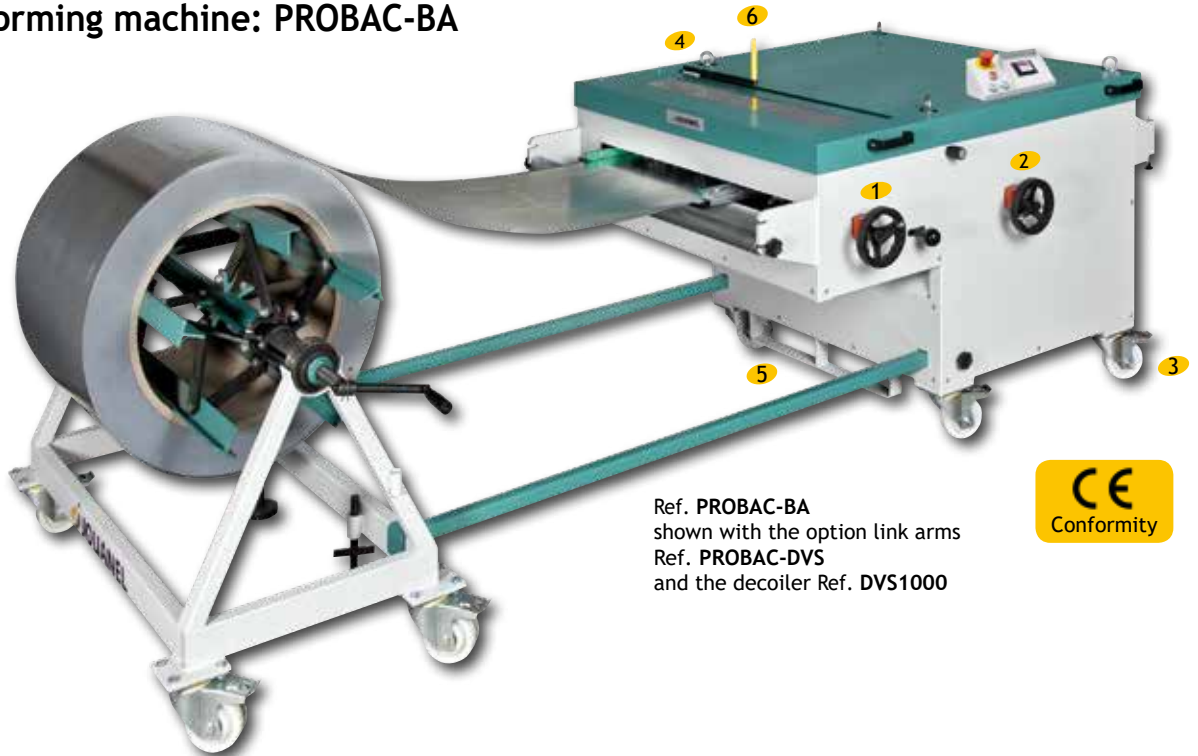

Ref. PROBAC-BA
shown with the option link arms
Ref. PROBAC-DVS
and the decoiler Ref. DVS1000



Standard equipment

- Wheel equipped with a counter to adjust the coil's entry guide **1**
- Wheel equipped with a counter to adjust the strip width **2**
- Set of 4 wheels equipped with brake **3**
- Slings rings **4**
- Guide for a better handling **5**
- Integrated in-feeding process
- Entry guide on « roller slide » to avoid marking the sheets

- Total or partial manual cross cut to recover offcuts **6**
- Longitudinal cut with or without roll forming
- Profile and tray width adjustment operated by 2 wheels equipped with counters
- 7 roll sets to ensure a high profiling quality and longevity of the material: treated steel, hardness 55HR, protected against corrosion by ion nitriding treatment.
- Metal sheet guiding process designed to form the conical trays (1 side after another)
- Programming of one tray length

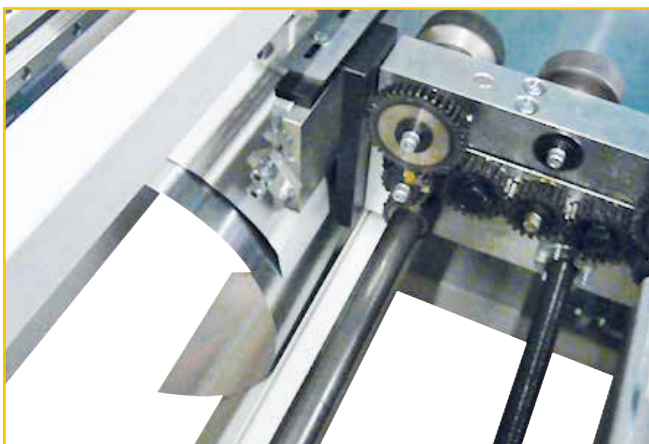

Partial cut with elimination of the offcut



Console with touch screen



Wheel with counter

Features	PROBAC-BA
Net weight (kg)	496
Dimensions (mm)	1600 x 1380 x 1000
Capacity (mm)	Zinc, Copper, 1050-H44 aluminum: 0,8
Power supply (V)	220V - single 16 A
Power (kW)	1,5
Roll forming speed (m/min)	10
Length accuracy (repetitively)	± 15 mm
Minimum length of trays (mm)	400
Slings rings	4

Electric roll-forming machines for standing seam PROBAC BA, HT, HT-CE



● Electric roll-forming machine: PROBAC-HT

Identical to the mode de Ref. **PROBAC-BA**, the models Ref. **PROBAC-HT** and **PROBAC-HT-CE** have the following technical advantages:

Rapidity (15 m/mn) and **accuracy** (+ / - 1 mm repetitively over 4 meters) thanks to their variable speed drive and their highly precise counter

Intuitive machine control on touch screen.

• To the operator's choice, 4 roll-forming menus:

- Manual without length or quantity programming, reading of the uncoiled length.
- Quick program menu: 1 length, 1 quantity
- Program menu, each program can be nominated and stored and contain several lengths and quantities which will work into each other automatically when manufacturing
- Specific menu for roll forming « side by side » for the first trays and conical trays allowing to suit the roll forming speed easily to guarantee a correct holding and support of the trays

Features	PROBAC-HT
Net weight (kg)	502
Dimensions (mm)	1600 x 1380 x 1000
Capacity (mm)	Zinc, Copper, 1050-H44 aluminum: 0,8
Power supply (V)	220V - single 20 A
Power (kW)	1,5
Variable roll forming speed (m/min)	5-15
Length accuracy (repetitively)	± 1 mm
Minimum length of trays (mm)	400
Minimum width of slitting (mm)	50
Slinging rings	4

- Maintenance menu informing the operator about the preventive maintenance actions to be carried out depending on the roll formed lengths accumulated
- Possible factory remote assistance by Internet link
- Totalizer and daily counter with reset possibility of the roll formed lengths
- Possible locking of the machine by password with several possible access levels (operator, maintenance, administrator)
- Speed +50%
- Touchscreen 7" wide 16/9 with sliding protective cap

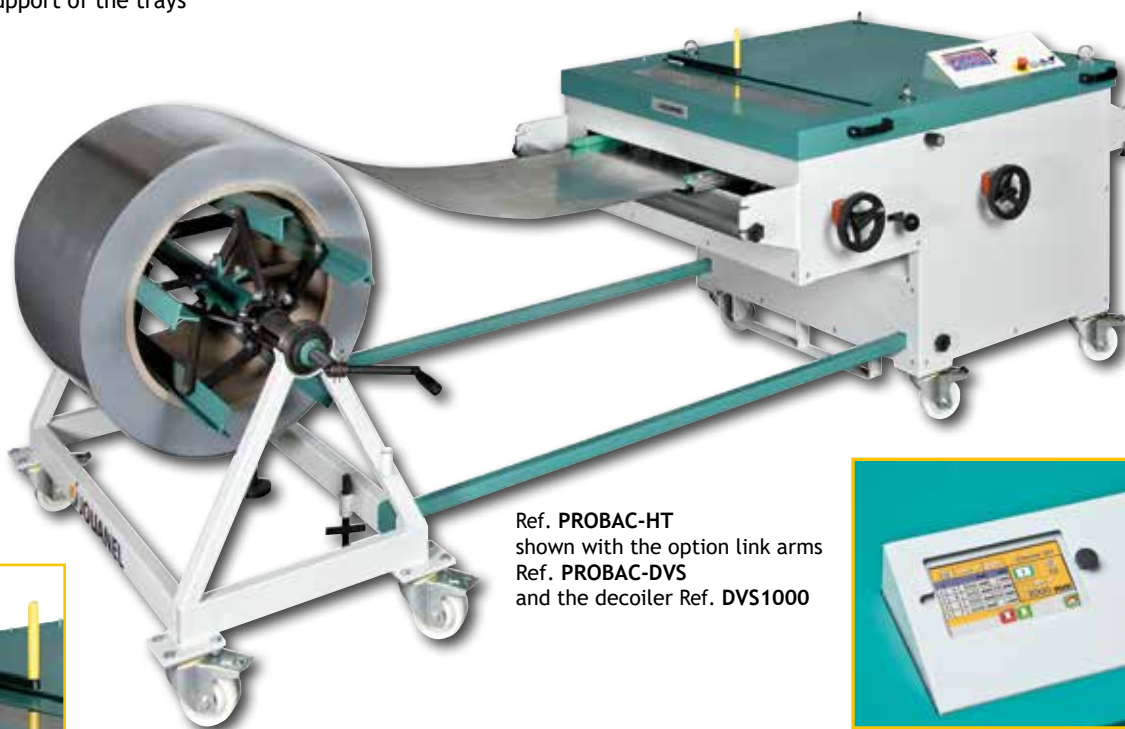

Ref. **PROBAC-HT**
shown with the option link arms
Ref. **PROBAC-DVS**
and the decoiler Ref. **DVS1000**



Manual transversal cut



Console with touch screen
for Ref. **PROBAC-HT**

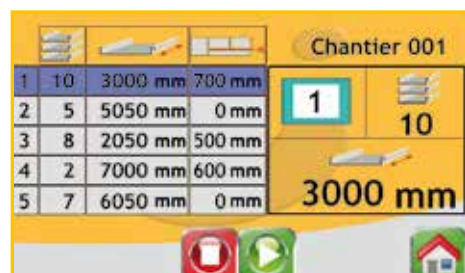

Touch screen views

Electric roll-forming machines for standing seam PROBAC BA, HT, HT-CE



● PROBAC-HT-CE

Machine identical to the Ref. PROBAC-HT with additional items:

- Electric transverse cut and automatic cycle allowing working several trays without intervention



Ref. PROBAC-HT-CE



DEMONSTRATION VIDEO available on YouTube® / Channel "Jouanel Industrie"

Features	PROBAC-HT-CE
Net weight (kg)	526
Dimensions (mm)	1600 x 1380 x 1000
Capacity (mm)	Zinc, Copper, 1050-H44 aluminum: 0,8
Power supply (V)	220V - single 20 A
Power (kW)	1,5
Variable roll forming speed (m/min)	5-15
Length accuracy (repetitively)	± 1 mm
Minimum length of trays (mm)	400
Minimum width of slitting (mm)	50
Slinging rings	4



4

Ref. PROBAC-HT-CE shown with the option link arms Ref. PROBAC-DVS and the decoiler Ref. DVS1000



Cutting tool



Console with touch screen for Ref. PROBAC-HT-CE

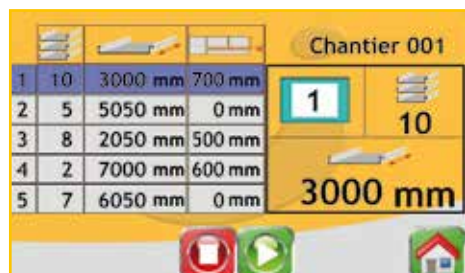

Touch screen views

Electric roll-forming machines for standing seam PROBAC BA, HT, HT-CE

The full or partial transversal cut ① allows to recover the offcut if there is slitting ②, see sketch below

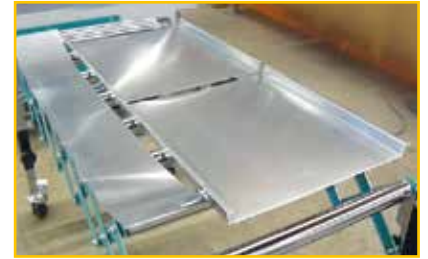
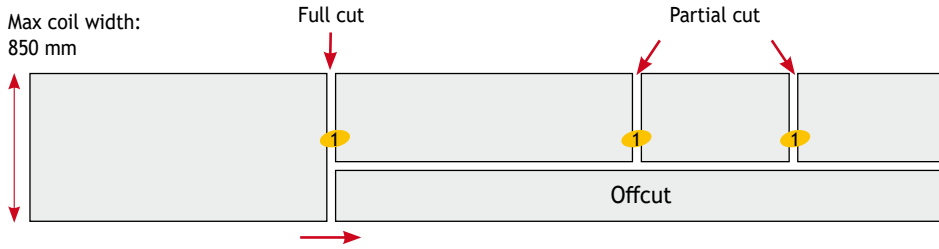

② Longitudinal cut

Remark:
The roll-forming machines PROBAC-BA, HT, HT-CE can also be used as cutting lines only

The adjustable longitudinal cut allows slitting and roll-forming simultaneously

Standard standing seam profile



Covering width (mm)	Minimum	Maximum
In 1 run	245	770
In 2 runs	65	700

Other possibilities



Covering width (mm)	Minimum	Maximum
In 1 run	115	765



Covering width (mm)	Minimum	Maximum
In 1 run	105	755



Covering width (mm)	Minimum	Maximum
In 2 runs	75	705



Covering width (mm)	Minimum	Maximum
In 2 runs	55	685

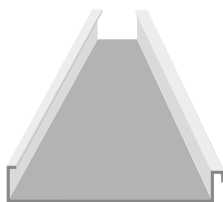

Conical tray

Covering width (mm)	Minimum	Maximum
In 2 runs	65	700



Options

- Beading rolls at the bottom of the tray: 2 x 20 x 1,5 mm Ref. **PROBAC-HT-NERV ③**
- Decoiler width 1 000 mm (maximum load 1 200 kg) Ref. **DVS1000** (p. 59)
- Two link arms for decoiler **DVS1000** Ref. **PROBAC-DVS ④**

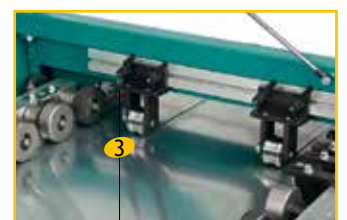

Beading rolls

Electric light roll-forming machines for standing seam PROBAC-LT, LT-C



● Electric light roll-forming machine: PROBAC-LT

Especially suitable for roll-forming works on building site

- Adjustment range: min 250 mm / max 800 mm
- Foldable entry guide
- Adjustment range by wheel
- 7 roll sets to ensure a high profiling quality and longevity of the material: treated steel, hardness 55HR, protected against corrosion by ion nitriding treatment
- Quick adjustment of the profiles return
- Guiding of the sheet made for the conical trays (1 side after another)
- 2 caster wheels + 2 legs + handling arm
- Straightener of trays at the exit

● Electric light roll-forming machine: PROBAC-LT-C

Idem Ref. PROBAC-LT with in addition, the manual transverse cut integrated ①

Features	PROBAC-LT	PROBAC-LT-C
Net weight (kg)	260	320
Dimensions (mm)	1200 x 1350 x 1050	
Capacity (mm)	Zinc, Copper, 1050-H44 aluminum: 0,8	
Power supply (V)	220V - single 20 A - 50Hz	
Power (kW)	1,1	
Roll forming speed (m/min)	9	
Minimum length of trays (mm)	400	
Slings rings	4	



① Manual transversal cut



Ref. PROBAC-LT-C

● Options

- Electromechanical length programmer Ref. PROBAC-LGPRO, accuracy 0/+2 cm (to be planned with the order) ②
- Decoiler width 1 000 mm (maximum load 1 200 kg) Ref. DVS1000 (p. 59)



② Electromechanical length programmer

Electric roll-forming machines for standing seam PROBAC-CPRO



Electric roll-forming machine: PROBAC-CPRO

Dismountable and transportable in 3 parts!

A roll-forming machine to shape trays withstanding seam, directly on the building site.

Its device for quick units disassembly allows easy shipping and handling without using mechanized lifting means.

The Compact-Pro roll-former is used for roll forming parallel trays for standing seam in a single pass or for conical trays and first trays in 2 runs

Standard equipment:

Frame:

- Frame made of welded-metal aluminum (1)
- 4 Adjustable blocks for levelling of the machine (2)
- Guiding rails allowing sliding the unit to adjust the tray in width (3)
- Metal sheet support guide, sliding, equipped with anti-marking nylon rollers (4)
- 4 fast releasing levers of units (5)
- 4 carrying handles (6)
- 4 slinging rings (12)

Roll-forming units:

- 2 roll-forming units equipped with 7 roll sets to ensure a high profiling quality and longevity of the material: treated steel, hardness 55HR, protected against corrosion by ion nitriding treatment (7)
- Straightening system of the metal sheet (8)
- Entry guides on slide and guiding on rolling bearings to make easy the material passage (9)
- Removable entry guides by releasing levers (10)
- 2 carrying handles per roll-forming unit (11)

Motor:

- Power supply: 220 V single-phase
- Power: 1,1 KW
- Roll-forming speed: 9m /mn
- Forward motion in a continuous operation, control by switch
- Backward motion, control by switch
- Emergency stop system

Options

- Profiling unit for cleat roofing trays, Ref. PROBAC-TASS, please contact us
- Two-wheeled decoiler for handling and uncoiling coils Ref. DVD1000 (p. 59) - width: 1m, Capacity: 200 kg

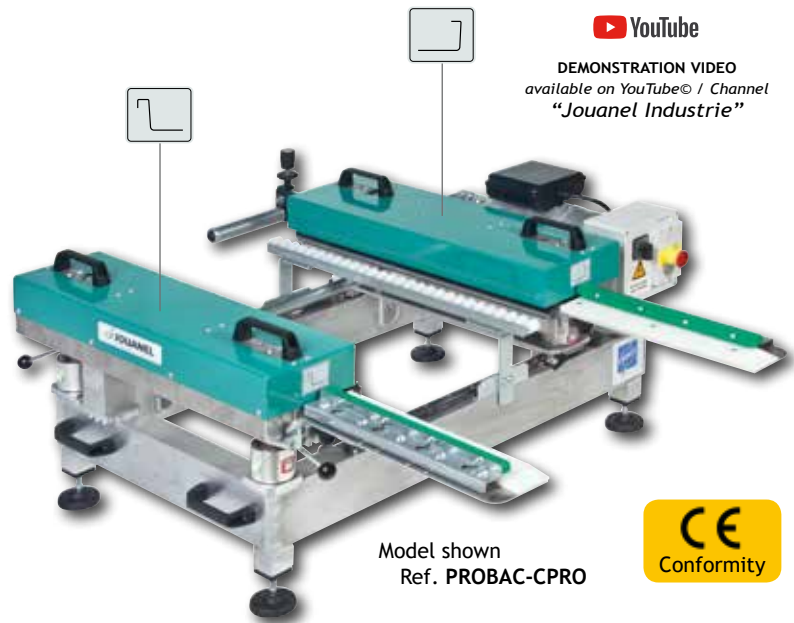
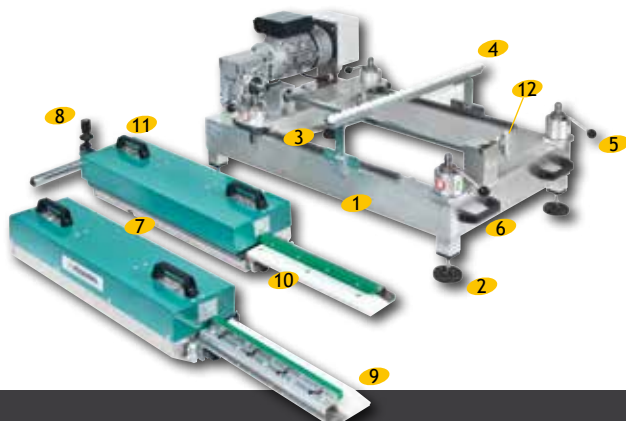

YouTube

DEMONSTRATION VIDEO
available on YouTube® / Channel
"Jouanel Industrie"

Model shown
Ref. PROBAC-CPRO



Features	PROBAC-CPRO
Minimum/maximum width	
Minimum sheet width in 1 run (mm)	205
Minimum sheet width in 2 runs (mm)	130
Maximum sheet width (mm)	720
Maximum capacity	
Steel (mm)	0,65
Zinc, copper, 1050-H44 aluminum (mm)	0,8
Dimensions	
Operating dimensions (LxH) (mm)	1 200 x 1 400 x 560
Dimensions of the frame with motor (LxH) (mm)	1 020 x 650 x 560
Net weight (frame + unit 1 + unit 2)	64 + 46,5 + 46,5



Electric roll-forming machines for standing seam - PROBAC-CPRO



Roll-formed conical tray in 2 runs

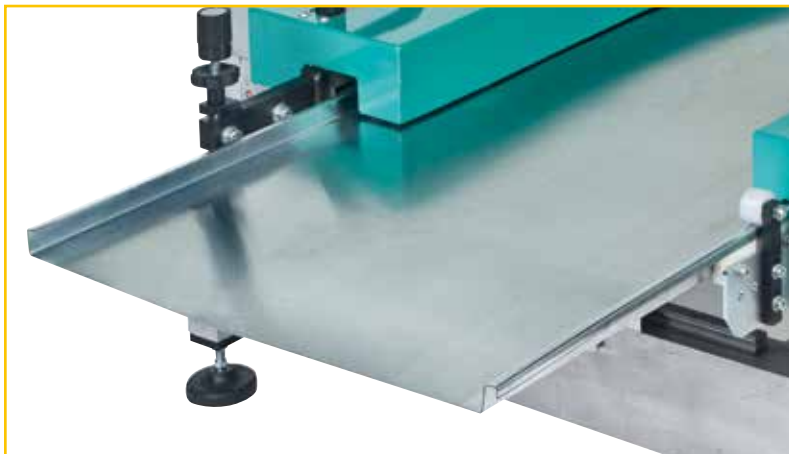

Roll-formed parallel tray in 1 run

Standard standing seam profile

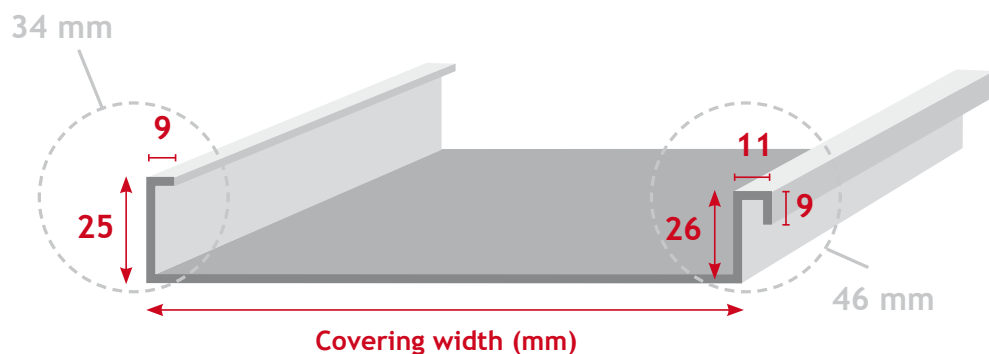

Covering width (mm)	Minimum	Maximum
In 1 run	125	640
In 2 runs	50	590

Other possibilities



Covering width (mm)	Minimum	Maximum
In 1 run	85	620



Covering width (mm)	Minimum	Maximum
In 1 run	40	630



Covering width (mm)	Minimum	Maximum
In 2 runs	85	600



Covering width (mm)	Minimum	Maximum
In 2 runs	40	550

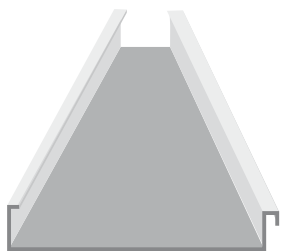

Conical tray

Covering width (mm)	Minimum	Maximum
In 2 runs	50	590

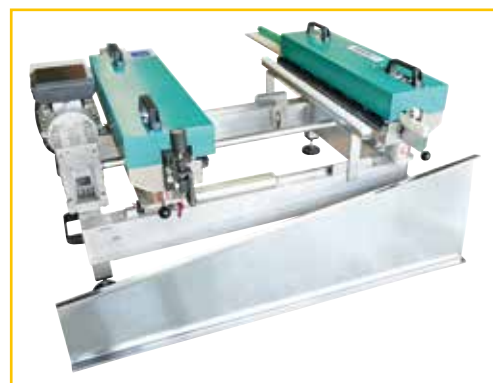

Light seamer for standing seam, 1st and 2nd fold - SRLT12

● Light seamer for standing seam 1st and 2nd fold: SRLT12

- Seaming unit for fold No. 1 and reversible for fold No. 2 (1)
- Quick lock/Unlock lever (2)
- Fold-out attachment for screw-gun (3)
- Pressure setting enables flattening adjustment, 5 positions (4)
- Support wheels (5)
- 3 sets of rolls
- Coated and hollowed out steel rolls
- Safety ring to keep tool from falling (6)
- Stackable carrying case with foam

NB : Cordless power tool not included with this model



Features	SRLT12
Maximum capacity for the 1st fold	
Capacity for zinc, copper and aluminum (mm)	0.8
Capacity for steel (mm)	0.7
Maximum capacity for the 2nd fold	
Capacity for zinc, copper and aluminum (mm)	0.7
Capacity for steel (mm)	0.6
Minimum radius arch-folded roofing (mm)	3000
Seaming speed (average, depending on screw-gun used) (m/mn)	50
Overall dimensions (L x w x h) (mm) Without screw-gun / fixing system folded in	332 x 244 x 115
Net weight, without screw-gun (kg)	5.5
Carrying case	yes

Instruction manual available on our website:
www.jouanel.com



 DEMONSTRATION VIDEO available on YouTube® / Channel "JOUANEL Industrie"

● Option for SRLT12 seamer: motorization kit SRLT12-KITBARD specific for standing seam cladding 1st fold for standing seam trays

More information on the product data sheet

Features	SRLT12-KITBARD
Maximum capacity for the 1st fold	
Capacity for zinc, copper and aluminum (mm)	0.8
Capacity for steel (mm)	0.7
Seaming speed (average) (M/mn)	50
Overall dimensions (L x w x h) (mm) with DeWALT screw-gun fixing on the seaming unit SRLT12	367 x 244 x 210
Manufacturer's warranty (in normal use)	1-year

NB: seaming unit not included



Electric seamers - SER

Seamers for standing seam allowing to lock the 1st and the 2nd seam

- Ref. **SER100A-05**: standard version
- Ref. **SER100A-05WAD**: version equipped with a set of cutting rollers Ref. **SER-05GALDEC** and automatic stop switch at the end of tray Ref. **SER-05SWITCH**



Model shown
Ref. **SER100A-05**

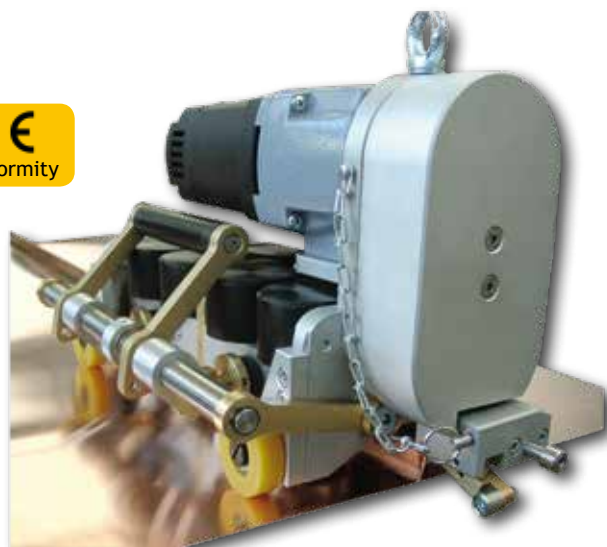

Model shown
Ref. **SER100A-05WAD**

Options

- Winter heating device Ref. **SER-05SETHIVER**
- Remote control with 12 m cable Ref. **SER-05TELECDE**
- Set of cutting rollers Ref. **SER-05GALDEC**

Model shown
Ref. **SER100A-05**
with the option
SER-05TELECDE



Model shown
Ref. **SER100A-05WAD**
with the option
SER-05SETHIVER

Features	SER100A-05	SER100A-05WAD
Weight (kg)	22	22
Minimum radius for curved roofing (mm)	1200	1200
Variable speed (m/min)	from 5,5 to 13 m/min	from 5,5 to 13 m/min
Power supply	230 v single-phase	230 v single-phase
Capacity (mm)	steel, zinc, copper, alu: 0,8 stainless steel: 0,5	steel, zinc, copper, alu: 0,8 stainless steel: 0,5
Minimum assembly length (mm)	140	140
Minimum operating temperature	10°C (without winter set)	10°C (without winter set)
Set of cutting rollers	No	Yes
Automatic stop switch at the end of tray	No	Yes

Electric slitting machine - RFD



● Electric slitting machine: RFD

This machine is specially designed for the longitudinal slitting of parallel trays and conical trays

- Distance between columns (maximum width of the sheet) 1 350 mm
- 1 set of blades Ø 118 mm
- Drive by rubber rollers
- Foot-operated control
- Ground shaft Ø 60 mm

● Options

- 1 additional set of blades Ref. RFD-CTSU* (to be planned with the order)
- Set of 4 braked wheels Ref. RFD-ROUL

Features	RFD
Weight (kg)	95
Speed (m/mn)	9
Power supply (V)	220 v single-phase
Power of the motor (kW)	0,37
Dimensions (mm)	1600 x 700 x 500
Capacity with one set of cutters* (mm)	lacquered steel: 0,65 aluminum: 1 zinc/copper: 0,8 stainless steel: 0,5
Operating height	420 /200
With / without wheels	

* Adding an extra set of blades reduces the cutting capacity

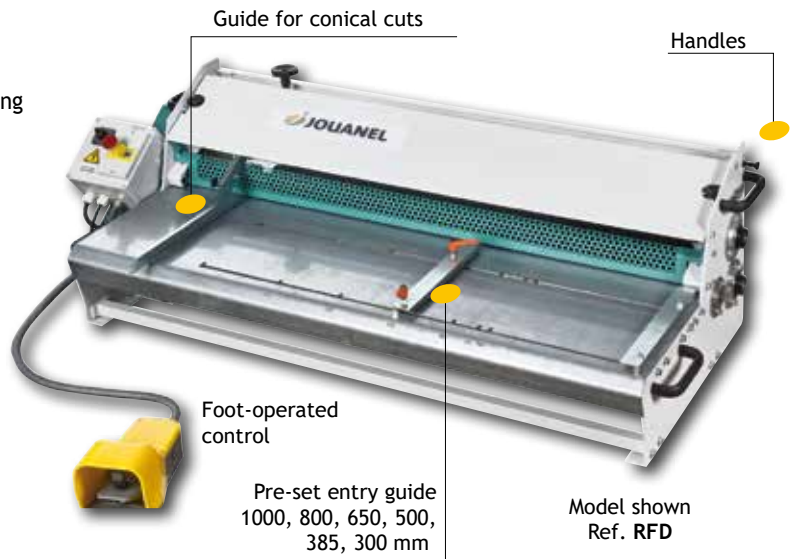

Electric arch-folding machine RCBPRO

● Electric arch-folding machine: RCBPRO

Machine designed for the bending of standing seam trays

- Equipped with 2 motors with variable speed to best adjust the bending on each side and the overall speed.
- Control by foot pedal and by switch (standard) allowing controlling the machine with hands free
- Forward/backward motion, step by step or continuous use

Features	RCBPRO
Weight (kg)	375
Minimum radius (mm), under condition and acc. to material	350
Dimensions (mm)	800 x 800 x 1 500
Power supply	220 v single-phase
Min-max capacity (mm)	zinc, copper, alu: 0,6-0,8



Examples of works



DEMONSTRATION VIDEO
available on YouTube© / Channel "Jouanel Industrie"

Decoilers - DVD, DVS

Decoiler: DVD1000

The two-wheeled decoiler is perfect to handle and uncoil 1 m-wide coils



Model shown
Ref. DVD1000

Features	DVD1000	
Maximum load (kg)	200	
Net weight (kg)	26	

Decoilers: DVS1000, DVS1250

- Equipped with 4 swiveling wheels with brake
- Wheel axis mounted on ball bearings
- Manual mandrel expansion from Ø 285 to 540 mm
- Maximum external diameter of the coil 1000 mm
- Manual brake on the same side as the handle allowing a quick adjustment
- Device allowing the rewind without action on the hub expander



Model shown
Ref. DVS1000



Features	DVS1000	DVS1250
Maximum load (kg)	1 200	1 000
Width (mm)	1 000	1 250
Net weight (kg)	126	130

Double decoiler: DVS1000D

- Floor space requirement: L.1270 x l.1335mm
- 2 hubs for coils width 1000 mm
- Manual expansion of the mandrel Ø 285 to 540 mm
- Maximum outer diameter of the coil 1000 mm
- Manual brake on the same side as the handle allowing a quick adjustment
- Device allowing the rewind without action on the hub expander



Model shown
Ref. DVS1000D

Features	DVS1000D	
Maximum coil width (mm)	1 000	
Maximum coil weight (kg)	1 200	
Maximum outer diameter (mm)	1 000	
Inside diameter of the coils (mm)	from 285 to 540	
Overall dimensions (L x l x h mm)	1 760 x 1 540 1 380	
Net weight (kg)	239	

Decoilers: DVS-E

The modular decoilers Ref. DVS1000E and DVS1250E optimize the storage and handling of your coils

- Manual mandrel expansion from Ø 285 to 540 mm
 - Maximum external diameter of the coil 850 mm
 - Maximum stacked up: 3 decoilers
 - Brake and handle on the same side
 - Possible lateral loading
 - Rewinding function
 - 2 Retractable and movable rollers  to guide and handle the sheet.
- Decoiling from the top or from the bottom

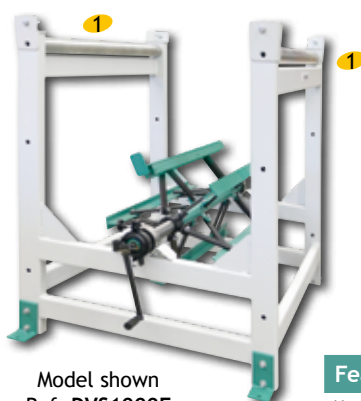

Model shown
Ref. DVS1000E



Features	DVS1000E	DVS1250E
Maximum load (kg)	1 200	1 000
Width (mm)	1 000	1 250

Additional hub of decoiler DVS

- For Ref. DVS1000, DVS1000D and DVS1000E : Ref. MOY-DVS1000
- For Ref. DVS1250 and DVS1250E : Ref. MOY-DVS1250
- Decoilers with other capacities upon request (4, 5, 10, 15 tons)

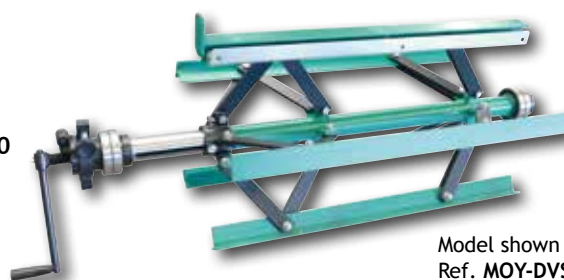

Model shown
Ref. MOY-DVS1000

Decoiler - DVM

Decoiler: DVM500

Decoiler for 0.5-m to 1.25-m wide coils

Especially easy to move around and transport in vehicles, this light and versatile model of decoiler is particularly suited to work on building sites

- Simple and sturdy design
- Base made of anti-corrosive zinc-plated steel
- 1 roller with fixed positioning
- 1 roller with adjustable positioning
- Carrying handle
- Base on anti-skid pads



Model shown
Ref. DVM500



Model
Ref. DVM500
(shown with
a 500 mm width coil)



Model Ref. DVM500
(shown with a 1000 mm
width coil)

	DVM500
Maximum load (kg)	500
End position of the movable roller (mm)	275
Min. distance between rollers (mm)	420
Max. distance between rollers (mm)	200
Base dimensions (L x l x h mm)	565 x 590 x 100
Overall dimensions (L x l x h mm)	610 x 590 x 210
Net weight (kg)	21

Roller table TRX

Extensible roller table: TRX

- Suitable to roll-forming and bending of standing seam trays and cleats, adjustable in height, they provide a perfect flatness at the exit of the machine.
- Possibility to fix each other in order to work with longer lengths.

Features	TRX
Height (mm)	670 to 940
Length (mm)	420 x 1300
Width (mm)	500
Ø of rollers (mm)	42
Number of rollers	9
Maximum load (kg)	150
Weight (kg)	42



Model shown
Ref. TRX

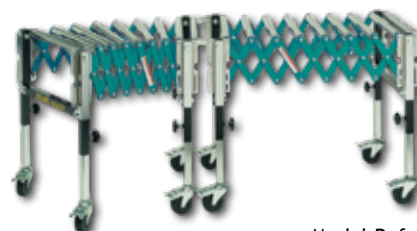

Model Ref. TRX
(shown with 2 units)

Asymmetrical roll-bending machines - CACDS, SDS

Manual roll-bending machine for work bench: CACDS33

Asymmetrical roll-bending machines for levelling, pinching and roll-bending of small diameters (\emptyset of the roller* x 1,5 = \emptyset of the hoop, approximately)



Features	CACDS33
\emptyset rollers (mm)*	33
Useful length (mm)	500
Capacity stainless steel / alu (mm)	0,5 / 0,7
Capacity S235JR steel (mm)	0,6
Control	Manual
Weight (kg)	34
Base: SSOCLE33	Optional

Model shown
Ref. CACDS33

Asymmetrical roll-bending machines: SDS

3 possible types:

- Manual M
- Electric with variable speed EVV

- Crowned rolls
- Rack-operated lever to adjust pinch and presser roller position rapidly 1
- Driving rollers on self-lubricating rings
- Brake motor
- emergency stop cable, for motorized model
- Safety guards of lower and upper rolls reducing the crushing risks

Features	SDS48M	SDS48EVV
\emptyset upper roll (mm)	48	48
Useful length (mm)	1 050	1 050
Capacity stainless steel / alu (mm)	0,7 / 1,2	0,7 / 1,2
Capacity S235JR steel (mm)	1,0	1,0
Control	Manual	Motorized Variable speed
Power supply (V)	-	220 1-ph
Power (kW)	-	0,75
Weight (kg)	95	150
Base: SDS48SOC	Optional	Included



Model shown Ref. SDS48M
+ Base SDS48SOC



Model shown
Ref. SDS48EVV



Asymmetrical roll-bending machines - ROL

Asymmetrical roll-bending machines: ROL

The ROL roll-bending machines have been specially designed for pinching and roll-bending thin metal sheets for ventilation, insulation, stove setting and workshops.

Standard equipment :

- To avoid marking the rolls, they are machined with high-carbon steel (24 HRC)
- For repetitive manufacturing the back roller is equipped with a counter allowing to find the selected position easily 1
- The lower roller is equipped with a position marker making easier its setting depending on the thickness 2
- For manufacturing seaming pipes the upper roller is equipped with a tangential slot
- For roll-bending of cones the machine is equipped with a movable gauge 3 and a tilting device of the back roll
- The hand-operated machines can be easily electrified after commissioning (Ref. KIT-ELEC-ROL)
- The motor is equipped with a variable-speed drive unit to adjust the rolling speed easily according to the works to be made
- The driving motor is equipped with a brake allowing accurate positioning of the metal sheet by eliminating the inertia effect



Model shown
Ref. ROL1050-15M

Safety of electrical models:

- Safety guards of lower and upper roll reducing the crushing risks
- Safety guard of gear pinions
- Emergency stop at the bottom by pressure onto the pedal
- Brake motor eliminating the driving risk by inertia
- CE Conformity

Features	ROL650-20M	ROL650-20EVV	ROL1050-15M	ROL1050-15EVV	ROL1270-12M	ROL1270-12EVV	ROL2050-06M	ROL2050-06EVV
Useful length (mm)	650	650	1050	1 050	1270	1270	2050	2050
Capacity stainless steel / alu (mm)	1,2 / 2,5	1,2 / 2,5	0,8 / 2	0,8 / 2	0,7 / 1,5	0,7 / 1,5	0,4 / 0,7	0,4 / 0,7
Capacity S235JR steel (mm)	2,0	2,0	1,5	1,5	1,2	1,2	0,6	0,6
Diameter of rollers*	upper and lower conical roller. 60 mm							
Hardness of rollers	90-100 kg/mm ²							
Minimum rolling diameter	80 to 120 mm acc. to thickness and type of metal sheet							
Working height	920 mm							
Power (kW)		0,75		0,75		0,75		0,75
Rotation speed of rollers	Manual	Variable 9 m/min	Manual	Variable 9 m/min	Manual	Variable 9 m/min	Manual	Variable 9 m/min
Power supply		220V, 1P+T		220V, 1P+T		220V, 1P+T		220V, 1P+T
Control	Crank	Double pedal forward backward	Crank	Double pedal forward backward	Crank	Double pedal forward backward	Crank	Double pedal forward backward
Dimensions L x l x h (mm)	1 100 x 610 x 1 175	1 100 x 750 x 1 175	1 500 x 610 x 1 175	1 500 x 750 x 1 175	1 720 x 610 x 1 175	1 720 x 750 x 1 175	2 500 x 610 x 1 175	2 500 x 750 x 1 175
Gross weight (kg)	196	236	226	266	251	291	365	405

∅ of the roller* x 1,5 = ∅ of the hoop, approximately

Asymmetrical roll-bending machines - RPL



Asymmetrical roll-bending machines: RPL

Asymmetrical roll-bending/levelling machines for pinching edges.

- Rollers machined with high-carbon steel (95/105 kg)
- Driving rollers bearings on a double needle roller cage for long term accuracy
- Wheel-operated presser roller adjustment with calibrated index position ①
- Easy lateral relief with holding of the roller in horizontal position ②
- Manual or electrically driven adjustment of the pinch roller with calibrated index ③

Exists in 3 versions

- **Type M** - Manual: wheel-operated adjustment, roll-bending by crank
- **Type E** - Semi-electrically driven machine: foot-operated motorized roll-bending and manual adjustment of the pinch roller
- **Type EE** - Full electrically driven machine: foot-operated motorized roll-bending and electric adjustment of the pinch roller



Model shown
Ref. RPL1550-30EE



Option: Conical rolling Ref. RPL-RCO

Features	RPL1050-20M	RPL1050-20E	RPL1050-30M	RPL1050-30E	RPL1050-30EE	RPL1050-40E	RPL1050-40EE	RPL1050-50EE	RPL1050-60EE
Useful length (mm)	1 050	1 050	1 050	1 050	1 050	1 050	1 050	1 050	1 050
Capacity S235JR steel (mm)	2	2	3	3	3	4	4	5	6
Ø rollers (mm)*	75	75	95	95	95	120	120	135	160
Control	M	E	M	E	EE	E	EE	EE	EE
Power supply (V)	-	400 V three phase	-	400 V three phase	400 V three phase	400 V three phase	400 V three phase	400 V three phase	400 V three phase
Power (kW)	-	0,75	-	1,1	1,1	1,5	1,5	2,2	3
Operating dimensions (mm)	L	1 700	1 600	1 650	2 600	2 520	2 520	2 520	2 600
	l	1 100	900	850	1 100	850	850	850	1 100
	h	1 330	1 100	1 200	1 100	1 200	1 200	1 200	1 350
Weight (kg)	400	510	780	1 090	1 200	1 370	1 400	1 580	1 900

Features	RPL1550-12M	RPL1550-12E	RPL1550-20M	RPL1550-20E	RPL1550-20EE	RPL1550-30M	RPL1550-30E	RPL1550-30EE	RPL1550-40E	RPL1550-40EE	RPL1550-50EE
Useful length (mm)	1 550	1 550	1 550	1 550	1 550	1 550	1 550	1 550	1 550	1 550	1 550
Capacity S235JR steel (mm)	1,2	1,2	2	2	2	3	3	3	4	4	5
Ø rollers (mm) *	75	75	95	95	95	120	120	120	135	135	160
Control	M	E	M	E	EE	M	E	EE	E	EE	EE
Power supply (V)	-	400 V three phase	-	400 V three phase	400 V three phase	-	400 V three phase	400 V three phase	400 V three phase	400 V three phase	400 V three phase
Power (kW)	-	0,75	-	1,1	1,1	-	1,5	1,5	2,2	2,2	3,0
Operating dimensions (mm)	L	2 020	2 050	2 150	3 020	3 020	2 650	3 020	3 020	3 020	3 100
	l	720	720	850	850	850	850	850	850	850	1 100
	h	1 100	1 200	1 100	1 200	1 200	1 200	1 200	1 200	1 200	1 200
Weight (kg)	540	570	820	1 470	1 500	1 520	1 570	1 600	1 770	1 820	2 200

Features	RPL2050-8M	RPL2050-8E	RPL2050-12M	RPL2050-12E	RPL2050-12EE	RPL2050-20M	RPL2050-20E	RPL2050-20EE	RPL2050-30E	RPL2050-30EE	RPL2050-40EE
Useful length (mm)	2 050	2 050	2 050	2 050	2 050	2 050	2 050	2 050	2 050	2 050	2 050
Capacity S235JR steel (mm)	0,8	0,8	1,2	1,2	1,2	2	2	2	3	3	4
Ø rollers (mm) *	75	75	95	95	95	120	120	120	135	135	160
Control	M	E	M	E	EE	M	E	EE	E	EE	EE
Power supply (V)	-	400 V three phase	-	400 V three phase	400 V three phase	-	400 V three phase	400 V three phase	400 V three phase	400 V three phase	400 V three phase
Power (kW)	-	0,75	-	1,1	1,1	-	1,5	1,5	2,2	2,2	3
Operating dimensions (mm)	L	2 520	2 570	2 650	3 520	3 550	3 520	3 520	3 550	3 520	3 600
	l	720	720	850	850	950	850	850	950	850	1 100
	h	1 100	1 100	1 200	1 200	1 200	1 200	1 200	1 200	1 200	1 200
Weight (kg)	720	750	1 650	1 770	1 850	1 740	1 770	1 850	2 020	2 055	2 500

Ø of the roller* x 1,5 = Ø of the hoop, approximately

● Line MLC1250

Cutting line with feeding, slitting and length cutting:

- Entry table with rollers and adjustable guides by means of a lever with counter, maximum width 1250 mm
- Motorized feeding station (1 steel roller + 1 rubber coated roller Ø 80 mm)
- Slitting station with corrected shafts Ø 100 mm, equipped with 3 sets of cutter blades Ø 154 mm adjustable with reading on tool
- Manual shaft adjustment by wheel and counter
- Minimum cutting width: 80 mm between cutter blades, 10 mm at edge
- Sets of reversing cutter blades mounted on one-piece cutter-blade blocks
- Mechanical guillotine shearing unit
- Maximum uncoiling speed: 20 m/mn
- Accuracy on cuts +/- 1 mm
- Possible use in manual mode

Numerical control:

- Control console mounted on a bracket with colour touch screen 7" (16:9)
- programs with 10 possible lengths (maximum 999 pieces per program)
- Indication of raising or lowering of the upper shaft automatically given to the operator by the CNC
- Naming and saving of the programs
- Possible use in manual mode
- **Remote maintenance (commissioning of the machine, remote updating)**

Model shown
Ref. MLC1250-HT-BD



- The lines MLC are also available without slitting station (please contact us)

● Options for all MLC

- Additional set of cutter blades* (MLC-C)
- Feeding selector, please contact us



Access and quick adjustment of cutter blades

● Line MLC1250-BD

Same equipment and max. uncoiling speed as the Ref. MLC1250 with a straightening station in addition:

- 3 steel rollers Ø 80 mm
- Position reading on a graduated screen

● Line MLC1250-HT

Same equipment and max. uncoiling speed as the Ref. MLC1250 with automatization in addition:

- Production management: total and partial cut lengths allowing saving material
- Slitting choice or not with automatic rise of upper cutter blades without loss of material
- Automatic upward/ downward motion of the slitting shaft
- Accuracy on cuts +/- 0,5 mm

● Line MLC1250-HT-BD

Same equipment and max. uncoiling speed as the Ref. MLC1250-HT with a straightening station in addition:

- 3 steel rollers Ø 80 mm
- Position reading on a graduated screen

Features	MLC1250	MLC1250-BD MLC1250-HT MLC1250-HT-BD
Weight (kg)	1 200	1 200
Dimensions (mm)	1 450 x 1 600 x 1 900	1 450 x 1 600 x 1 900
Power of motors Feeding / straightening (kW)	1,5	1,5
Power shearing unit (kW)	1,1	1,1
Power rise of cutter blades (kW)	-	0,18
Power supply	230 V (phased + ground), 20 A	400 V (three-ph + neutral + ground), 16 A
Capacity steel shearing S235JR (mm)	1,2	1,2
Capacity steel slitting S235JR with 3 cutter blades* (mm)	1	1

* Caution, the addition of extra set of cutter blades reduces the cutting capacity when slitting

Manual light cutting unit - CLD-LT



Essential for a fast productive capacity of zinc, stainless steel or steel lengths intended for shaping, without effort. Adapted to thin metal steel works: roofing, zinc works, insulation and heat protection, the manual or electric cutting units will offer working with comfort and safety

• Direct manual uncoiling, manual cutting: CLD-LT

Standard equipment

Uncoiling:

- Manual uncoiling by pulling or pushing
- Adjustable input guides from 250 to 1250 mm on slides and locking handles (1)
- Guiding of the sheet on ball bearings (2)
- Free roller at the entrance to guide the sheet in height (3)
- Entry table with nylon protection to avoid any marking under the metal sheet
- Locking in position by eccentric and free wheel

Cutting:

- Sheet clamping beam by rubber roller with reverse-lock device of the coil (4)
- Manual cutting by roller shear (5)
- Guiding on ground rail and ball pad
- Ground blades made of tempered steel 58 HRC

Handling/shifting:

- 4 caster wheels diameter 70 mm on ball bearings with brake (6)

• Options

- Measuring wheel with digital display at 1/10 (7) Ref. CLD-COMPTEUR
- Exit table with socket adaptor to connect several tables (8) Ref. CLD-TAB-1M
Length 1 000 x width 1 250 x height 740 mm (adjustment +/- 15 mm)
Maximum load of exit table: 250 kg
- Portable decoiler widths 500 to 1250 mm (maximum load 500 kg) Ref. DVM500
- Decoiler width 1 000 mm (maximum load 1 200 kg) Ref. DVS1000
- Decoiler width 1 250 mm (maximum load 1 000 kg) (9) Ref. DVS1250

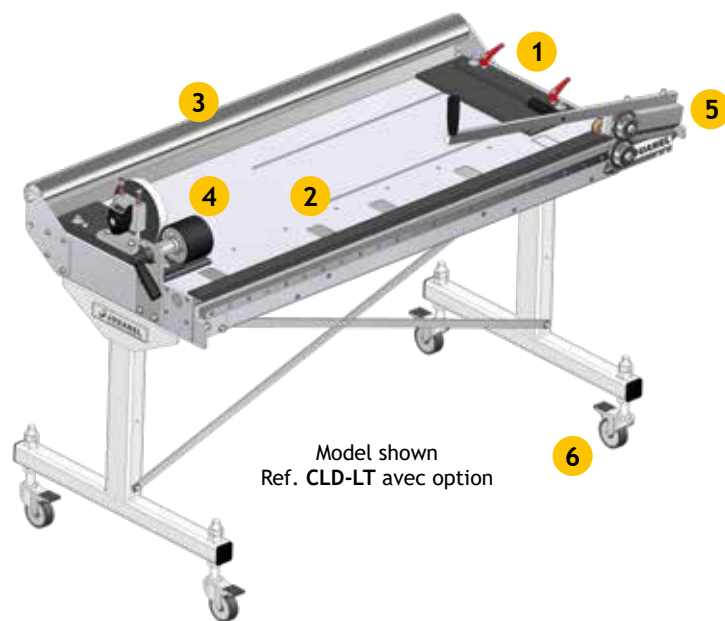

Model shown
Ref. CLD-LT avec option

Features	CLD-LT
Maximum cutting capacity	
Soft steel (mm)	0,7
Zinc, Copper, 1050-H44 aluminum (mm)	0,8
Stainless steel (mm)	0,5
Uncoiling	
Minimum width of the coil (mm)	250
Maximum width of the coil (mm)	1 250
Dimensions	
Operating dimensions (mm)	1 610 x 800 x 1 110
Sheet overhead clearance (mm)	825 (adjustable +/- 15 mm)
Transport dimensions (mm)	1 700 x 1 100 x 1 300
Net weight (kg)	80
Gross weight (kg)	130

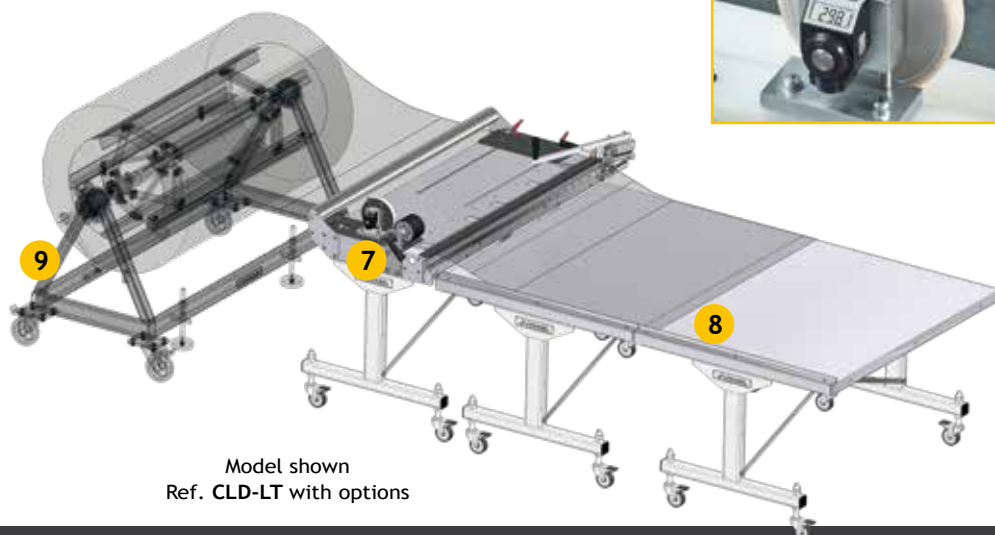

Model shown
Ref. CLD-LT with options



Manual uncoiling by crank, manual cutting: CLD-AM

Standard equipment

Uncoiling:

- Manual uncoiling by crank (1)
- Drive by rubber rollers
- Adjustable input guides from 250 to 1250 mm on slides and locking handles (2)
- Guiding of the sheet on ball bearings (3)
- Free roller at the entrance to guide the sheet in height (4)
- Entry table with nylon protection to avoid any marking under the sheet metal
- Locking in position by eccentric and free wheel

Cutting:

- Sheet clamping beam by rubber roller with reverse-lock device of the coil (5)
- Manual cutting by roller shear (6)
- Guiding on ground rail and ball pad
- Ground blades made of tempered steel 58 HRC

Handling/shifting:

- 4 caster wheels diameter 70 mm on ball bearings with brake (7)

Options

- Measuring wheel with digital display at 1/10 (8)
Ref. **CLD-COMPTEUR**
- Exit table with socket adaptor to connect several tables (9)
Ref. **CLD-TAB-1M**
Length 1 000 x width 1 250 x height 740 mm (adjustment +/- 15 mm)
Maximum load of exit table: 250 kg
- Portable decoiler widths 500 to 1250 mm (maximum load 500 kg) Ref. **DVM500**
- Decoiler width 1 000 mm (maximum load 1 200 kg) Ref. **DVS1000**
- Decoiler width 1 250 mm (maximum load 1 000 kg) (10) Ref. **DVS1250**

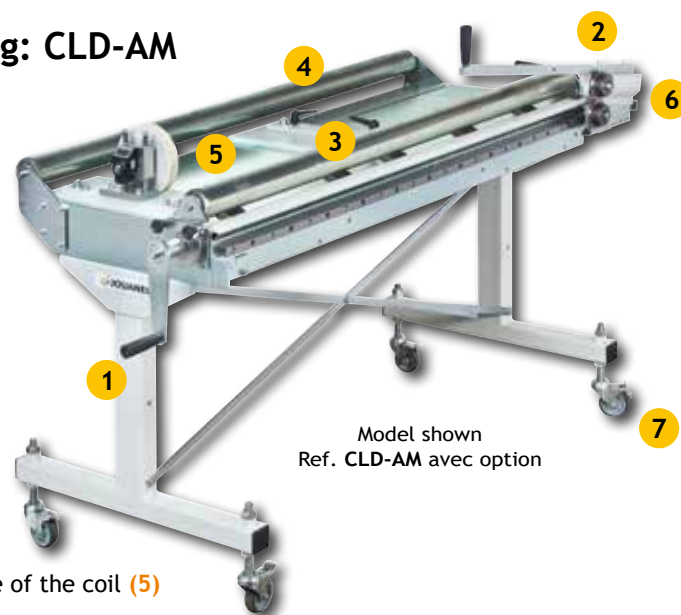

Model shown
Ref. CLD-AM avec option

Features	CLD-AM
Maximum cutting capacity	
Soft steel (mm)	0,7
Zinc, Copper, 1050-H44 aluminum (mm)	0,8
Stainless steel (mm)	0,5
Uncoiling	
Minimum width of the coil (mm)	250
Maximum width of the coil (mm)	1 250
Dimensions	
Operating dimensions (mm)	1 800 x 800 x 1 110
Sheet overhead clearance (mm)	825 (adjustable +/- 15 mm)
Transport dimensions (mm)	2 000 x 1 100 x 1 300
Net weight (kg)	95
Gross weight (kg)	240

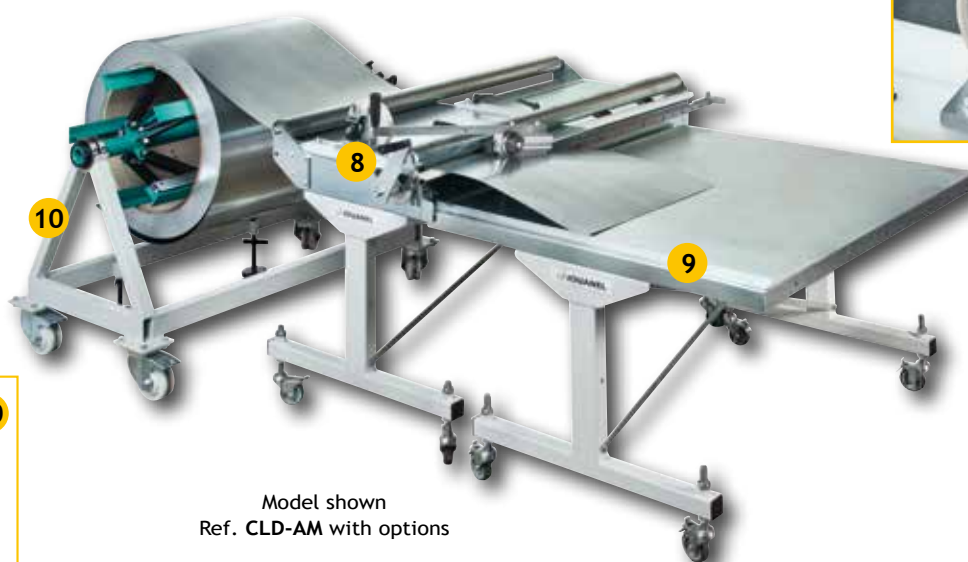

Model shown
Ref. CLD-AM with options



Semi-electric light cutting unit - CLD-AE



● Electric uncoiling, manual cutting, length measurement: CLD-AE

(Machine also exist with slitting, Ref. CLD-AE-REF, consult us)

Standard equipment

Uncoiling:

- Electric uncoiling
- Power supply 220 V, single-phase 0,18 KW
- Maximum speed 9 m/mn
- Electronic length programmer, accuracy +/- 15 mm (1)
- Drive by rubber rollers
- Adjustable entry guides from 250 to 1250 mm on slides and locking handles (2)
- Guiding of the sheet on ball bearings
- Free roller at the entrance to guide the sheet in height (3)
- Entry table with nylon protection to avoid any marking under the metal sheet

Cutting:

- Sheet clamping beam by rubber roller with reverse-lock device of the coil
- Manual cutting by roller shear (4)
- Guiding on ground rail and ball pad
- Ground blades made of tempered steel 58 HRC

Handling/shifting:

- 4 caster wheels diameter 70 mm on ball bearings with brake (5)

● Options

- Exit table with socket adaptor to connect several tables (6)
Ref. CLD-TAB-1M
Length 1 000 x width 1 250 x height 740 mm
(adjustment +/- 15 mm) maximum load of exit table: 250 kg
- Portable decoiler widths 500 to 1250 mm (maximum load 500 kg)
Ref. DVM500
- Decoiler width 1 000 mm (maximum load 1 200 kg) Ref. DVS1000
- Decoiler width 1 250 mm (maximum load 1 000 kg) (7) Ref. DVS1250



Model shown
CLD-AE



Features	CLD-AE
Maximum cutting capacity	
Soft steel (mm)	0,7
Zinc, Copper, 1050-H44 aluminum (mm)	0,8
Stainless steel (mm)	0,5
Uncoiling	
Minimum width of the coil (mm)	250
Maximum width of the coil (mm)	1 250
Dimensions	
Operating dimensions (mm)	1 800 x 800 x 1 110
Sheet overhead clearance (mm)	825 (adjustable +/- 15 mm)
Transport dimensions (mm)	2 000 x 1 100 x 1 300
Net weight (kg)	140
Gross weight (kg)	210



Electronic length programmer

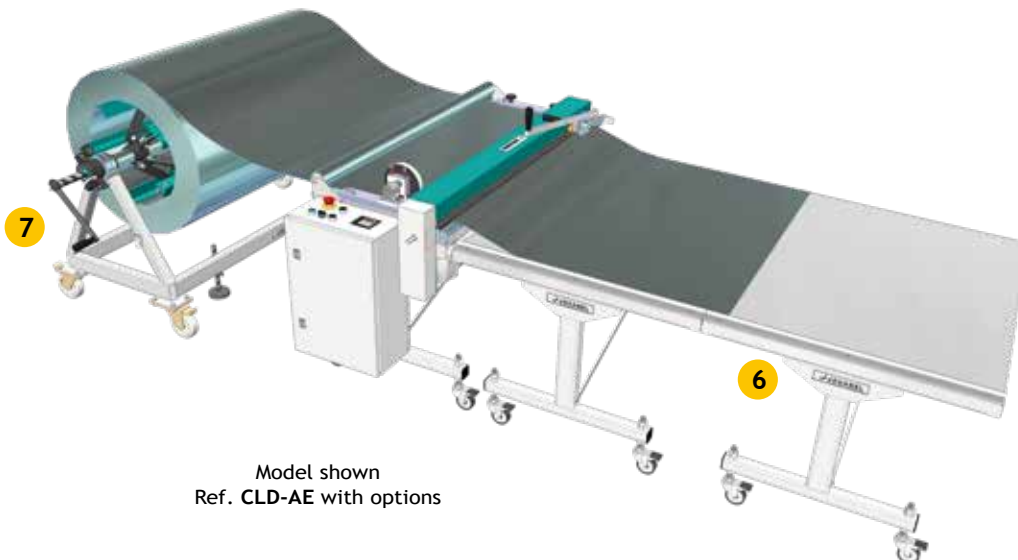

Model shown
Ref. CLD-AE with options



● Electric uncoiling, electric cutting, numerical control: CLD-AE-CTE

(Machine also exist with slitting, Ref. CLD-AE-CTE-REF, consult us)

Standard equipment

Uncoiling:

- Electric uncoiling
- Power supply 220 V, single-phase 0,18 KW
- Automatic variable speed drive for smooth starting-up and stop
- Maximum speed 12 m/mn
- Drive by rubber rollers
- Adjustable entry guides from 250 to 1250 mm on slides and locking handles (1)
- Guiding of the sheet on ball bearings
- Free roller at the entrance to guide the sheet in height (2)
- Entry table with nylon protection to avoid any marking under the metal sheet
- Length measuring wheel

Electric cutting:

- Sheet clamping beam by rubber roller with reverse-lock device of the coil
- Electric cutting by roller shear (3)
- Guiding on ground rail and ball pad
- Ground blades made of tempered steel 58 HRC

Handling/shifting:

- 4 caster wheels diameter 70 mm on ball bearings with brake (4)

Numerical control:

- Possible programming of several quantities and several lengths
- Automatic cycle making the machine work without an operator
- Manual cycle to work on an ad hoc basis
- High accuracy of length cut: +/- 2 mm over 2M
- Use of the machine protected by a password
- Manual or automatic speed adjustment
- Colour touch screen 7" (5)



Model shown
CLD-AE-CTE

Control console
with touch screen

Features	CLD-AE-CTE
Maximum cutting capacity	
Soft steel (mm)	0,7
Zinc, Copper, 1050-H44 aluminum (mm)	0,8
Stainless steel (mm)	0,5
Uncoiling	
Minimum width of the coil (mm)	250
Maximum width of the coil (mm)	1 250
Dimensions	
Operating dimensions (mm)	1 800 x 800 x 1 110
Sheet overhead clearance (mm)	825 (adjustable +/- 15 mm)
Transport dimensions (mm)	2 000 x 1 100 x 1 200
Net weight (kg)	190
Gross weight (kg)	260

● Options

- Exit table with socket adaptor to connect several tables (6)
Ref. **CLD-TAB-1M**
Length 1 000 x width 1 250 x height 740 mm
(adjustment +/- 15 mm) maximum load of exit table: 250 kg
- Portable decoiler widths 500 to 1250 mm
(maximum load 500 kg) Ref. **DVM500**
- Decoiler width 1 000 mm (maximum load 1 200 kg)
Ref. **DVS1000**
- Decoiler width 1 250 mm (maximum load 1 000 kg) (7)
- Ref. **DVS1250**

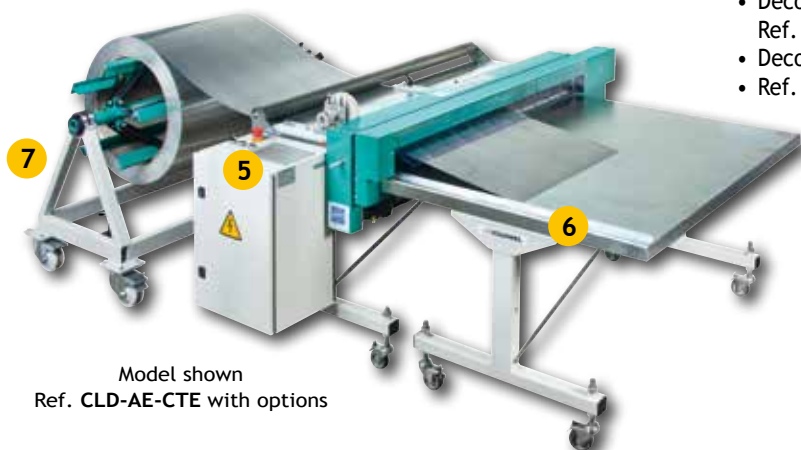

Model shown
Ref. CLD-AE-CTE with options



The expertise of a manufacturer!

JOUANEL Industrie includes, for several years now, a R&D department specialized in the manufacturing of specific machinery to work thin metal sheets for its industrial clients. Drawing on its skills in the manufacturing of machine-tools, JOUANEL Industrie will suggest the right solution perfectly matching your manufacturing process.

A custom-made machine complying with your needs

We design and manufacture your machine for you and with you, in compliance with your specifications and your own colors. Our highly-experienced R&D department, as well as our knowledge in mechanics, hydraulics, automatism and numerical controls are our assets when we design machines with the latest technological innovations developed by Jouanel.

● Examples of achievement



Other cutting units

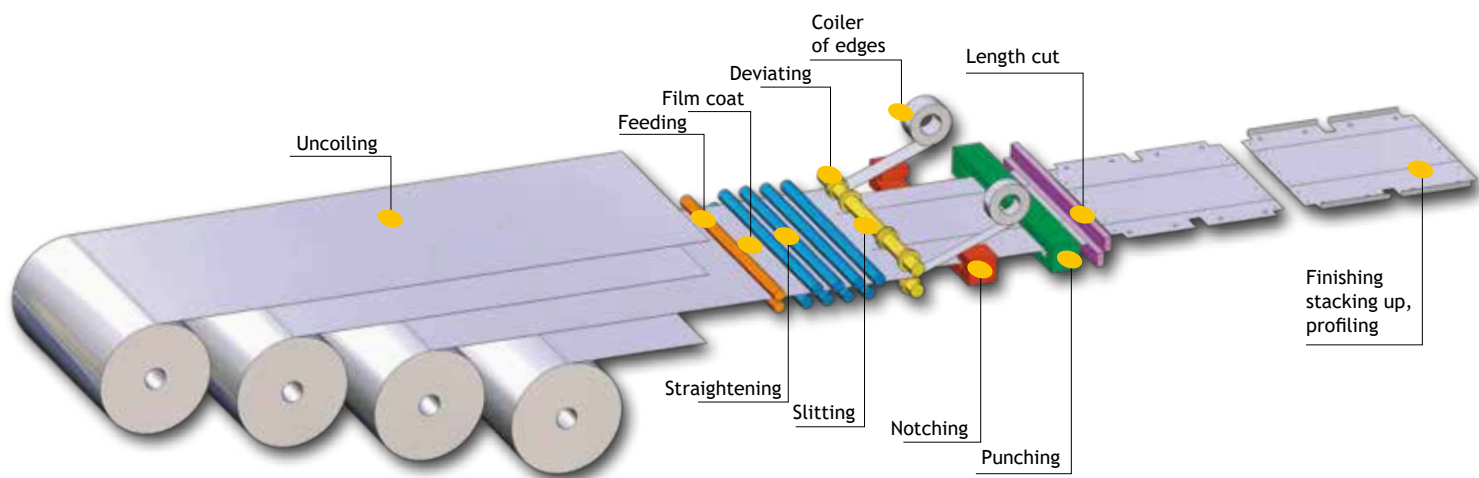

Open side decoiler



Laser control of the loop



Pressure arm



Coil loading carriage

Miscellaneous equipment

Flat bar folding machine - PFP

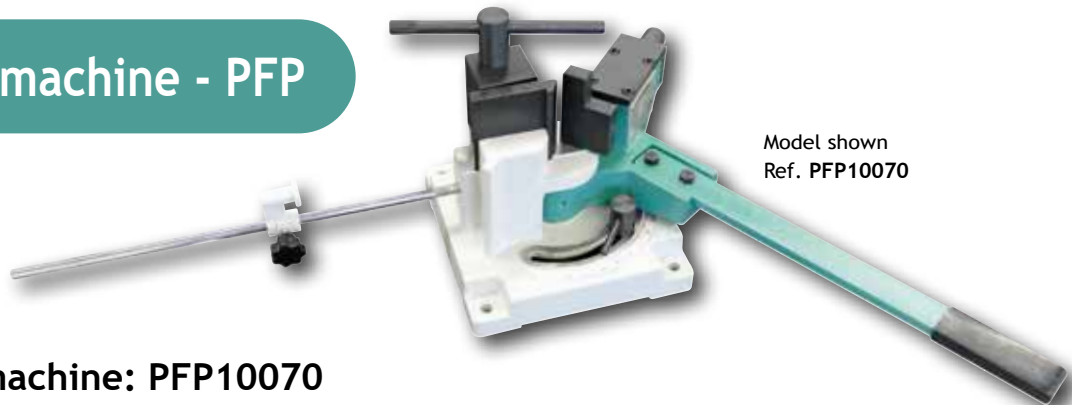

Model shown
Ref. PFP10070

• Flat bar folding machine: PFP10070

- Sturdy and reliable folding machine with steel jaws. The vice is standard equipped with an operating device by eccentric for a quick and easy clamping

Maximum capacity cold-rolled steel (mm)	Maximum capacity copper (mm)	Dimensions (mm)	Weight (kg)
■ 100 x 7	■ 100 x 10	330 x 330 x 350	35

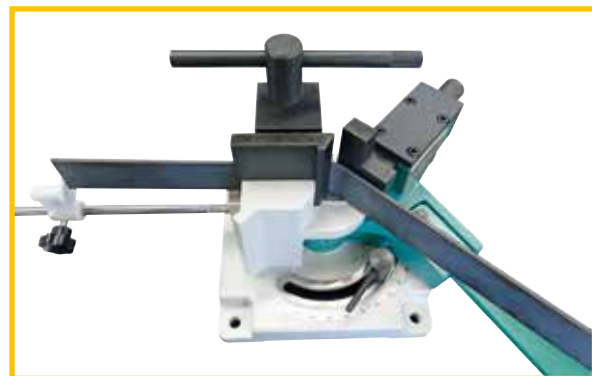

Hand corner notcher - ENC

• Hand corner notcher 90°: ENC-150-15

Strong and reliable, the hand corner notcher for work bench with fixed angle is a machine allowing an easy and fast right angle cut.

- Cutting angle 90°
- Adjustable graduated gauge
- Capacity steel S235JR: 1,5 mm
- Maximum notching: 150 mm x 150 mm
- Dimensions: 610 mm x 530 mm x 600 mm
- Weight: 95 kg
- For hydraulic version fixed angle 90° or variable 200x200x4 mm (please contact us)



Model shown
Ref. ENC-150-15

Miscellaneous equipment

Shears for metal sheet - CLP





- Shears for metal sheet, flat iron, round iron, square iron, angle steel and T-shape (acc. to model)



Safety: tension spring on the upper blade



Different possibilities of cuts on Ref. CLP10C

Features	CLP1C	CLP2C	CLP4C	CLP6C	CLP7C	CLP10C
Length of lower blades (mm)	125	150	200	250	300	175
Cutting capacity* when reworking on the first 1/4 of blade (mm)	3	3	4	4	4	6
Cutting capacity* over the whole length (mm)	2	2,5	3	3	2	5
 (mm)	60 x 3	60 x 3	80 x 4	80 x 4	100 x 4	70 x 6
 (mm)	8	8	10	10	10	15
 (mm)	-	-	-	-	-	15
 (mm)	-	-	-	-	-	50 x 5
 (mm)	-	-	-	-	-	30 x 30 x 4
Weight (kg)	10	11,5	18	23	28	95
Motion transfer	by rod	by rod	by rod	by rod	by rod	by rack

* steel S235JR



Model shown Ref. CLP10C supplied with lever

Light manual roofing machines (portable)

Manual arch-folding machine for beads - CMB-ET

This light roofing accessory is designed to manually arch zinc, copper or alu strips which have a 13 to 18 mm Ø bead.

Once the part has been bent acc. to the desired radius, it will perfectly fit dormers and bent roof borders for a quality finish.

A convex or concave bend is made in several passes, by moving the part back-and-forth in the arch-folding device. The obtained radius results from the progressive increase in pressure of the two bending rollers on the part, thanks to the adjusting wheel.

The rollers in high density nylon make a regular bend without marking the material.

- Arch-folding diameter (min.): 1000 mm
- Bending capacity: zinc, copper and alu (min.-max): 0.5 - 0.8 mm
- Rollers in high density nylon
- 1 set of grooved rollers Ø 19 mm
- 1 set of pinch roller
- Fixing system for vice or workbench included 
- Dimensions: 200 x 200 x 170 mm
- Weight (kg): 2,8

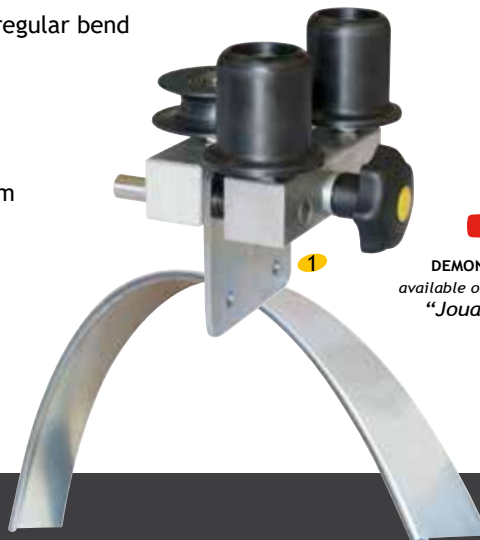

 YouTube

DEMONSTRATION VIDEO available on YouTube® / Channel "Jouanel Industrie"



Light manual roofing machines (portable)

Hand edge rollers and accessories

No friction, no marking!

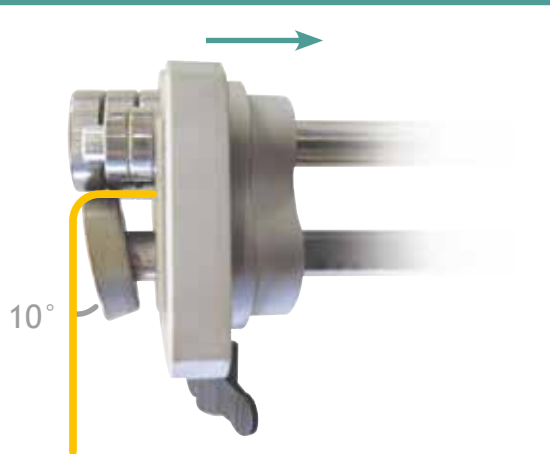

The shape of the « folder » roller will enable a fold up to 100° in order to balance the resilience of the material and get a real seam at 90° with no marking of the material.



Hand edge rollers: very practical for a real pro!

Easy to handle and light, the hand edge roller makes neat and regular seams and counter-seams, whatever the wished length. They are equipped with treated steel rollers and stainless steel rolls that guarantee a long lifetime of the tool as well as a stable and accurate guidance.

Available with single and double column, equipped with 2 or 4 rolls, the Jouanel hand edge rollers have all technical advantages of the market edge rollers.

Once the height of the seam is defined with the graduated column, it just to slide the edge roller against the metal sheet, by successive to-and fro movements and by inclining gradually until you get the desired angle.

• Single column hand edge roller with 2 guide rolls: PLIMSC2

Standard equipment

- For straight or roll-bent metal sheets
- Single-piece body made of aluminum, machined and anodized
- Columns, rolls and shafts in stainless steel
- Folder roller made of hardened steel, inclined at 10°
- To fold up to 100° in order to compensate the elastic return of material
- 2 guide rolls
- Graduations in mm on flat surface
- Double locking of edge height by butterfly handle
- Removable handle for use with maximum edge height
- PVC black handle
- Fabric storage pocket



Ref. PLIMSC2-200



Features	PLIMSC2-050	PLIMSC2-100	PLIMSC2-200	PLIMSC2-350
Capacity zinc and alu (mm)	1	1	1	1
Capacity copper (mm)	0,8	0,8	0,8	0,8
Capacity steel (mm)	0,7	0,7	0,7	0,7
Capacity stainless steel (mm)	0,5	0,5	0,5	0,5
Edge height (mm)	5 to 50	5 to 100	5 to 200	5 to 350
Net weight (g)	1010	1165	1470	1925

Options

- Transport case with protective foams for hand edge rollers single column from 50 to 200mm

Light manual roofing machines (portable)

• Single column hand edge roller with 4 guide rolls: PLIMSC4



DEMONSTRATION VIDEO available on YouTube®
Channel "Jouanel Industrie"

Standard equipment

- For straight or roll-bent metal sheets
- Single-piece body made of aluminum, machined and anodized
- Columns, rolls and shafts in stainless steel
- Folder roller made of hardened steel, inclined at 10°
- To fold up to 100° in order to compensate the elastic return of material
- 4 guide rolls
- Graduations in mm on flat surface
- Double locking of edge height by butterfly handle
- Removable handle for use with maximum edge height
- PVC black handle
- Fabric storage pocket

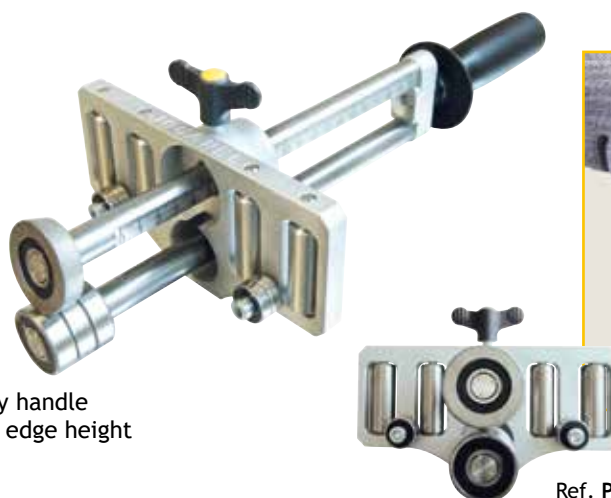

Ref. PLIMSC4-200



Features	PLIMSC4-050	PLIMSC4-100	PLIMSC4-200	PLIMSC4-350
Capacity zinc and alu (mm)	1	1	1	1
Capacity copper (mm)	0,8	0,8	0,8	0,8
Capacity steel (mm)	0,7	0,7	0,7	0,7
Capacity stainless steel (mm)	0,5	0,5	0,5	0,5
Edge height (mm)	5 to 50	5 to 100	5 to 200	5 to 350
Net weight (g)	1210	1360	1665	2120

Options

- Transport case with protective foams for hand edge rollers single column from 50 to 200mm

• Double column hand edge roller with 3 guide rolls: PLIMDC3

Standard equipment

- To fold over large lengths
- Single-piece body made of aluminum, machined and anodized
- Columns, rolls and shafts in stainless steel
- 2 folder rollers made of hardened steel, inclined at 10°
- To fold up to 100° in order to compensate the elastic return of material
- 3 guide rolls
- Graduations in mm on flat surface
- Double locking of edge height by 2 butterfly handles
- Removable handle for use with maximum edge height
- PVC black handle
- Fabric storage pocket

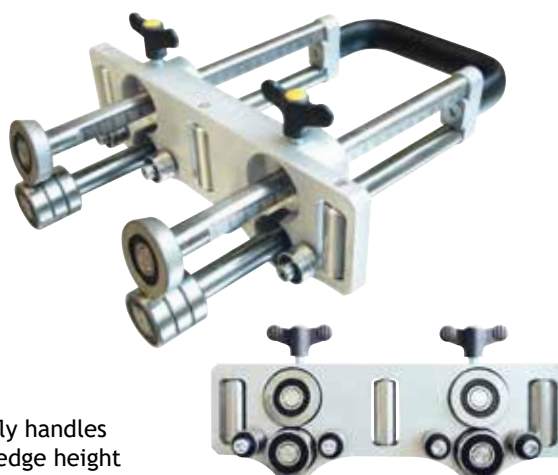

Ref. PLIMDC3



Features	PLIMDC3-200	PLIMDC3-350
Capacity zinc and alu (mm)	1	1
Capacity copper (mm)	0,8	0,8
Capacity steel (mm)	0,7	0,7
Capacity stainless steel (mm)	0,5	0,5
Edge height (mm)	5 to 200	5 to 350
Net weight (g)	3075	3990

Option

- Holding accessory for double-columned hand edge rollers
Ref. PLIMDC-FIX



Light manual roofing machines (portable)

• Single disk hand edge roller: PLIMSD1-040

Hand edge rollers with single disk, 1 guide roll enabling to make clamps at 180° on some edges from 8 to 40 mm. Very easy to handle and compact, this disk roller will complete your equipment.

Standard equipment

- Single-piece body made of aluminum, machined and anodized
- No adjustment to be made
- To make hems at 180° from a seam at 90° easily
- 1 stainless steel roll
- 1 folder disk made of treated steel diameter 100 mm
- PVC black handle
- Fabric storage pocket

Features	PLIMSD1-040
Capacity zinc and alu (mm)	1
Capacity copper (mm)	0,8
Capacity steel (mm)	0,7
Capacity stainless steel (mm)	0,5
Edge height (mm)	8 to 40
Net weight (g)	630

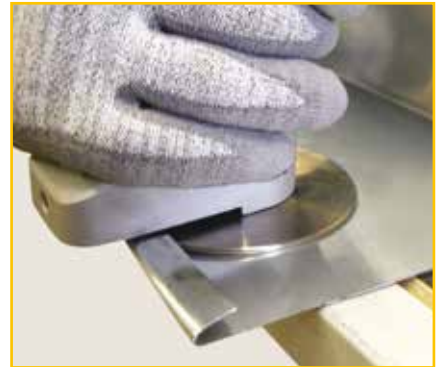

Options

- Transport case with protective foams for single disk hand edge roller

• Tool to close hems at 180°



DEMONSTRATION VIDEO available on YouTube® Channel "Jouanel Industrie"

Very quick to use over the large lengths

From a seam at 135°, the tool OFP-180 enables you, with rapidity and comfort, a plating at 180°, with one pass thanks to its 4 sets of rollers. The last roller is adjustable for a perfect setting acc. to the thickness and the material. For this operation the sheet must be strictly held on the bench.

Standard equipment

- Regular folding on the whole length in one pass
- Gain in time
- Capacity of folding 0,8 mm steel
- 4 sets of rollers
- Upper roller adjustable in position and in depth
- 2 adjusting wheels
- 2 holding handles

Features	OFP-180
Capacity steel (mm)	0,8
Net weight (g)	1800



« Parisian » type folding machine PAL

Easily transportable to the building sites

• « Parisian » type PAL2040 1

- Light and sturdy design made of aluminum: 30kg
- Adaptable on trestles
- Rigid clamping beam equipped with 4 « piano » hinges for a better quality of fold
- Shaping of standard folds and seams in Ø 13 mm
- 2 cranks

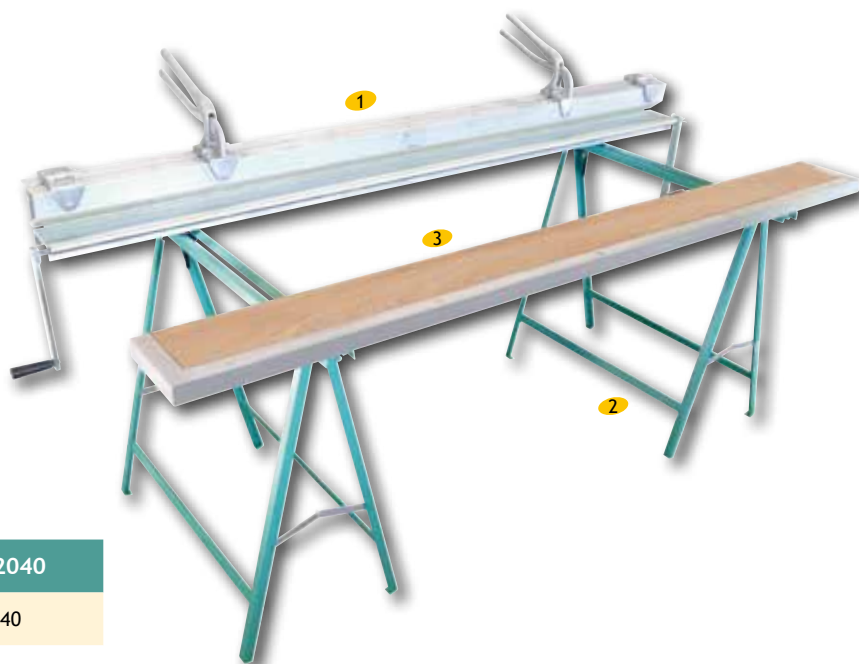

Features	PAL2040
Useful folding length (mm)	2040
Capacity zinc (mm)	0,65
Folding depth over 2m (mm)	100
No depth limit on 1m (between handles)	-
Passage between handles (mm)	1 070
Dimensions (mm)	2 200 x 420 x 500
Net weight (kg)	30
Passage between handles (mm)	Ø 13



• Options

• Metal trestles Ref. TRET-METAL 2

Designed for the fixing of the folding machine PAL2040 and of the edging board

- Foldable feet
- Width: 900 mm
- Height: 750 mm
- Weight: 16 kg



• Edging board Ref. PB2040 3

Edging board, made of exotic rot-proof wood

- Galvanized steel angles on 3 sides
- Length 2 040 mm x width 190 mm
- Weight : 15 kg



Pipe flaring tool EVA



DEMONSTRATION VIDEO
available on YouTube® / Channel
"Jouanel Industrie"

• Pipe flaring tool: EVA

The downpipe flaring tool, model EVA from Jouanel Industrie, enables you to enlarge very easily electro-welded downpipes with diameters of 80 mm or 100 mm, in order to fit them together according to your needs .

Useable in a workshop or on a building site, its cranked crank-driven hub device is very efficient and ensures a perfectly managed flaring in depth, regularity and quality.



Model shown
Ref. EVA80

Set to the choice:

- Set with base **1** and hub **2** Ø 80 mm Ref. EVA80
- Set with base and hub Ø 100 mm Ref. EVA100
- Set with base and hubs Ø 80 and Ø 100 mm Ref. EVA80-100

• Options

- Hub Ø 80 mm Ref. EVAS-D80
- Hub Ø 100 mm Ref. EVAS-D100

1

Model shown
Ref. EVA80 with base
and hub Ø 80 mm



Model shown
Ref. EVA80
with pipe to flare

Example of achievement:
pipes fit together thanks to the flaring tool Ref. EVA

Features	EVA80	EVA100	EVA80-100
Maximum flaring depth (mm)	100	100	100
Capacity Zinc / Copper (mm)	0,8	0,8	0,8
Hub's net weight with crank (Kg)	4,2	5,4	4,2 + 5,4
Base's net weight (Kg)	13,6	13,6	13,6
Base's dimensions l x P x H (mm)	160 x 250 x 460	160 x 250 x 460	160 x 250 x 460
Gross weight of the set (Kg)	24,6	25,8	30,2

NB: not suitable for seamed pipes and tin welded truncated pipes

Slate-cutter - CA600

The strongest slate cutter
in its class!

Convenient, efficient, strong

The slate-cutter CA600 is the essential tool to shape slates at will on constructions sites.

Its strengthened disc, mounted on steel guides and ball bearing, ensures an excellent cutting regularity and effortless handling.

Its large sized cutting plate and its quickly adjustable square gauges will enable the most diverse cuts with great productivity.

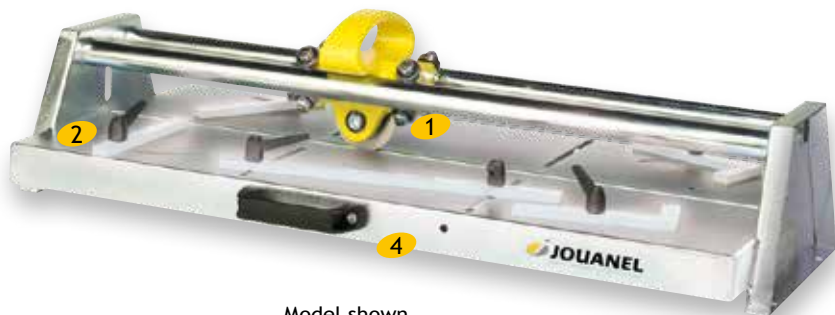

Model shown
Ref. CA600

- Slate and fiber-cement cutting
- Strengthened cutting disc for thick slates up to 6 mm (removable and changeable disc)
- Guiding of the cutting carriage on 8 bearings (1)
- Long table for slates up to 600 mm
- Square gauges with quick adjustment system (2) facilitating:
 - Slate positioning
 - Hold during the cut / while cutting
 - Series cut
- 2 gauges with grooved graduations every 5 mm
- Table and guide in galvanized steel treated against corrosion
- Buffers for shock absorption buffers at end position
- Hanging up on lintel and safe fixing by brads
- Locking system of the carriage for transportation (3)
- Wide handling handles - 2 positions (4)
- Made in France by Jouanel Industrie

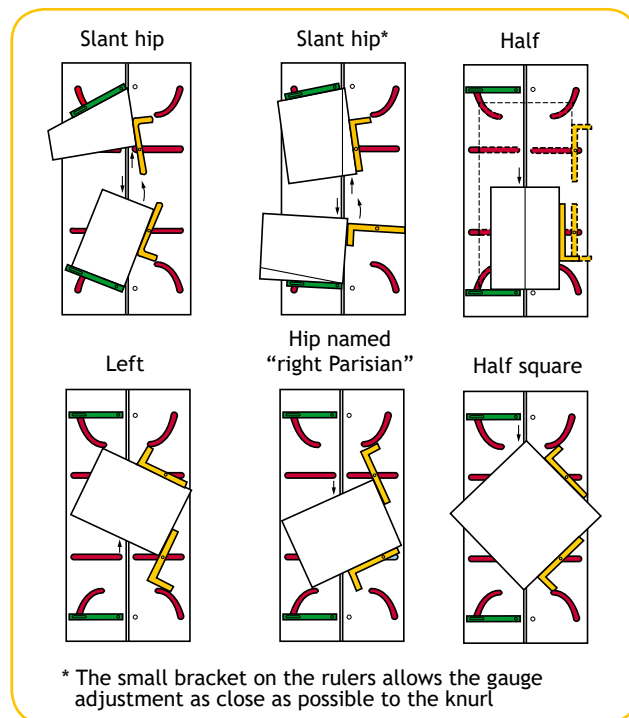

Features	CA600
Overall dimensions (mm)	935 x 420 x 250
Plate length (mm)	885
Plate width (mm)	420
No of bearings	8
No of square gauges	5
Max. cutting thickness (mm)	6
Gross weight (kg)	19,2



A know-how recognized by our customers

The company JOUANEL Industrie, located in Sainte Maure-de-Touraine in Indre-et-Loire, designs, manufactures and markets since 1948, machine-tools dedicated to craftsmen and industrialists processing metal sheets within the different applications areas of building metal envelope, insulation and air duct manufacturing.

Our know-how of more than 70 years in the field of folding, shearing and roll forming has assured the very good reputation of our firm to the roofers and zinc workers. Jouanel Industrie thus became a leading player in this business against its national competitors, all of them importers.

Application areas of our machines

- Roofing
- Cladding-Facade
- Metal carpentry
- Metal frameworks
- Ironworks-Sheet metal works
- Insulation
- Air duct manufacturing
- Maintenance workshops
- Trade school education



Our products

With more than 72 references manual, electric, hydraulic our machines, with or without CNC, Jouanel Industrie covers the key elements of the market needs in processing zinc, copper, steel, prelacquered or aluminum in coils or sheets. We thus offer all the equipment solutions which will ease the work of the operators by significantly improving the workshops' productivity.



Unlike our challengers, our strength lies in our ability to develop very quickly our machines to meet the customers' requirements. With four to five new models per year and many technical innovations brought onto the existing models along the year, inaction and immobility have no room at Jouanel's.

Besides our standard products, we have cultivated over the years the ability to design and provide «special» machines, thanks to the reactivity of our R&D department and the great flexibility of our production processes. With internal aptitudes in all fields linked to the design and the fabrication of modern and efficient machine-tools (design, machining, mechanics, automatism, hydraulics, CNC...), Jouanel Industrie assists its customers in their specific equipment projects.



Technical assistance SAT & SAV

At JOUANEL Industrie, we stay with you after the sale to:

- ⊕ Schedule the commissioning of your machine
- ⊕ Perform the contractual interventions
- ⊕ Provide spare parts
- ⊕ Provide technical documentation
- ⊕ Operate a Hotline for mechanical repairing
- ⊕ Do remote assistance on the CNC

Our departments can be reached from Monday to Friday from 8:00 am to 5:00 pm

- ⊕ Technical Assistance Department: (+33) 2 47 65 47 65
- ⊕ After-sales department: (+33) 2 47 65 16 49
- ⊕ Hotline CNC, automatism, software: (+33) 2 47 65 16 46



index

A	
Additional equipment for PCA, PCX, PBS, PVS, PZX, PVX	15-17
Asymmetrical roll-bending machines CACDS, SDS, ROL, RPL	62-64
C	
Clamping beam with guide rail TCZ.....	30
Compact cutting units MLC.....	65
D	
Decoilers DVD, DVS, DVM	60-61
E	
Electric BAGPRO and manual beading machines BAGMP	44-45
Electric arch-folding machine RCBPRO.....	59
Electric guillotine shears CGS, CGI.....	35-41
Electric roll-forming machines for standing seam PROBAC	50-56
Electric seamers SER	58
Electric slitting machine RFD	59
Electric universal folding machines PTL, PTS.....	20-25
Extra long folding machines PGL	26-27
F	
Flat bar folding machine PFP	72
H	
Hand corner notcher ENC.....	72
Hand edge rollers and accessories PLIM.....	74-76
Hydraulic guillotine shears CHS	42-43
L	
Light cutting units CLD	66-69
Light seamer for standing seam - 1st and 2nd fold - SRLT12	57
M	
Manual arch-folding machine for beads CMB-ET	73
Manual building site folding machines PCL and PCA	4-5
Manual folding machines PCX.....	6-7
Manual guillotine shears CGM.....	31-34
Manual lever-operated shears CL	30
Manual workshop folding machines PVS.....	14
Manual workshop folding machines PVX	9
Manual workshop folding machines with segmented clamping beam PVXT	10
Manual workshop folding machines PZX.....	8
Manual workshop folding machines and electric clamping PBS	14
P	
« Parisian » type folding machine PAL.....	77
Pipe flaring tool EVA	78
Press brakes PPS	28-29
R	
Roller table TRX.....	61
Roll-forming machines for cleat roofing tray PBC650	49
S	
Segmented folding machines HS.....	18-19
Semi-electric workshop folding machines PVX PE	11
Semi-electric workshop folding machines with segmented clamping beam PVX TPE	12-13
Shears for metal sheet CLP	73
Slate-cutter CA600	79
Special roll-forming machines for roofing accessories	48
Swaging machines SB with sets of rolls SBMOL	46-47

Printed
10/2019



30 rue des Saulniers • 37800 Sainte-Maure-de-Touraine
FRANCE • FR15331327072
Tél. : +33 2 47 65 40 67 • Fax : +33 2 47 65 51 61
e-mail : info@jouanel.com



www.jouanel.com

Your distributor:

