

SMART CB19 CONTROL BOX

SWING GATE OPENERS

24V DC MOTOR
FOR RESIDENTIAL
USER MANUAL

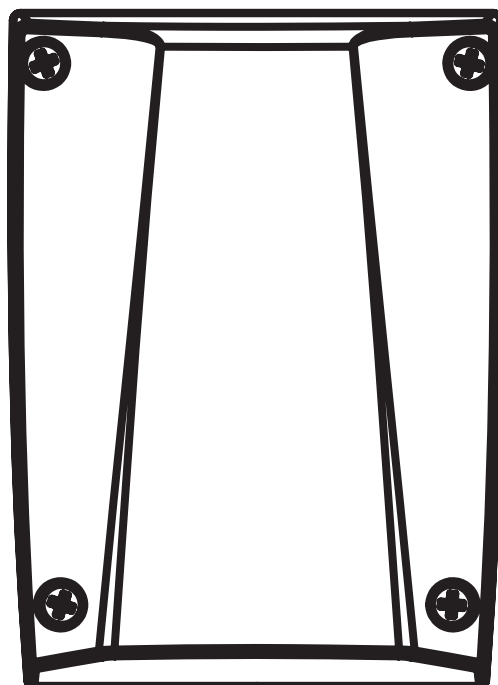

Reuse
Reduce
Recycle



Index

1). Control Box Installation	2
2). Wiring Connection	2
2.1 Motor Connection	3
2.1.1 Motor Only	3
2.1.2 Motor With Limit Switch	3
2.1.3 Motor With Hall Sensor	3
2.2 Back-up Batteries	4
2.3 Accessories	5
2.3.1 Photocells	5
2.3.2 Green Box	6
3). Get Started	7
3.1 Step 1: Remote Memorizing	7
3.1.1 Memorizing	7
3.1.2 Erasing	7
3.2 Step 2: System Learning	8
3.3 Testing	8
4). Gate Operation Logic	9
5). Safety For Gate Operation	9
6). LED Indication	9
6.1 LED Lighting	9
6.2 Function of the LED display	9
7). Parameter Modification	10
7.1 Parameter Learning	10
7.2 Parameter	10
7.3 Photocell Logic	12
8). Trouble Shooting	13
9). Technical Specification	14

1). Control Box Installation

1. Decide the installation position of control box first, it is suggested to be installed near the gate and should be protected from possible damage. Be aware of the motor cable length before deciding the installation position.
2. Remove the cover by unscrewing the four screws on the cover. See **Figure A**.
3. Use a screwdriver to puncture the holes beneath the bottom of the control box. See **Figure B**.
4. Secure it on the wall **Figure C**.

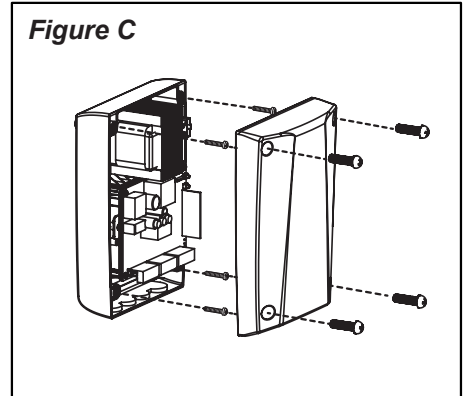
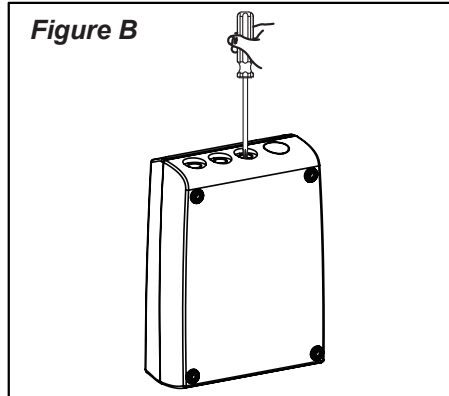
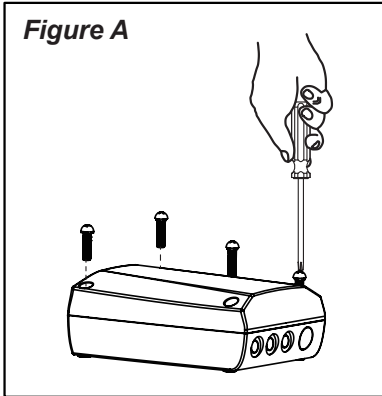

2). Wiring Connection

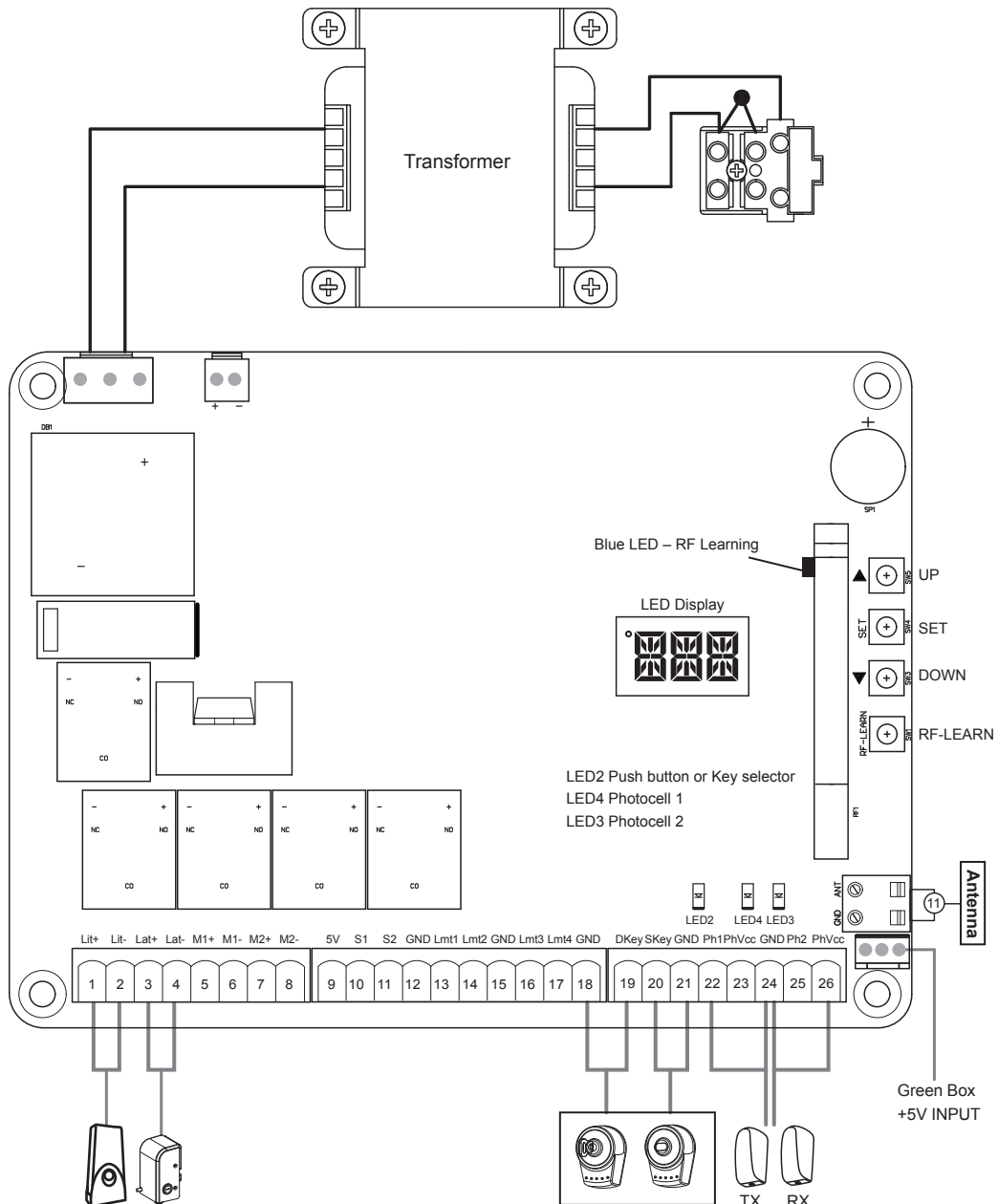

2.1.1 Motor Only

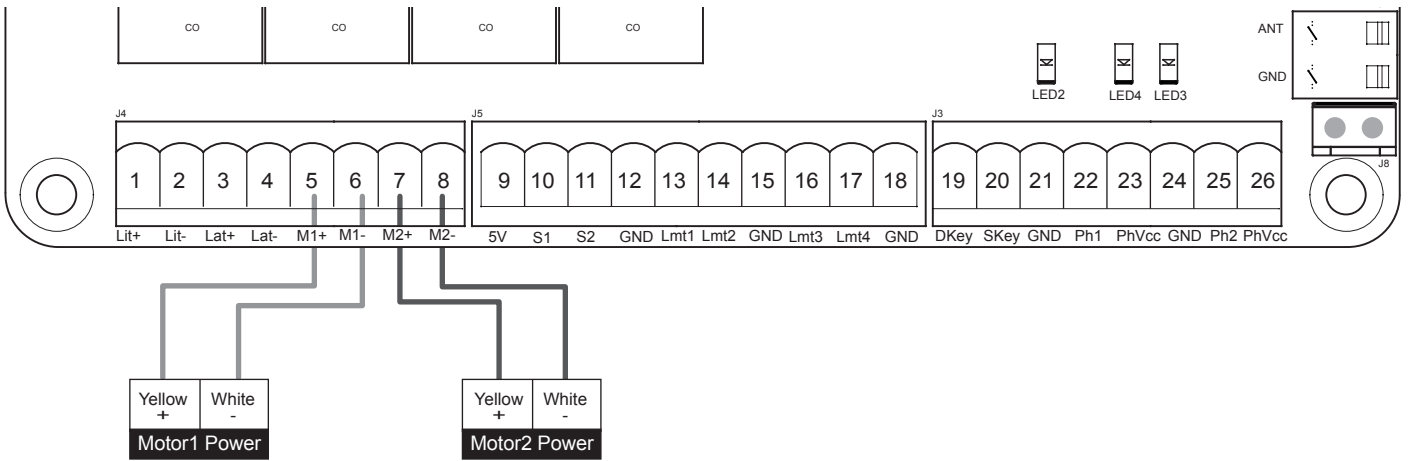

2.1.2 Motor With Limit Switch

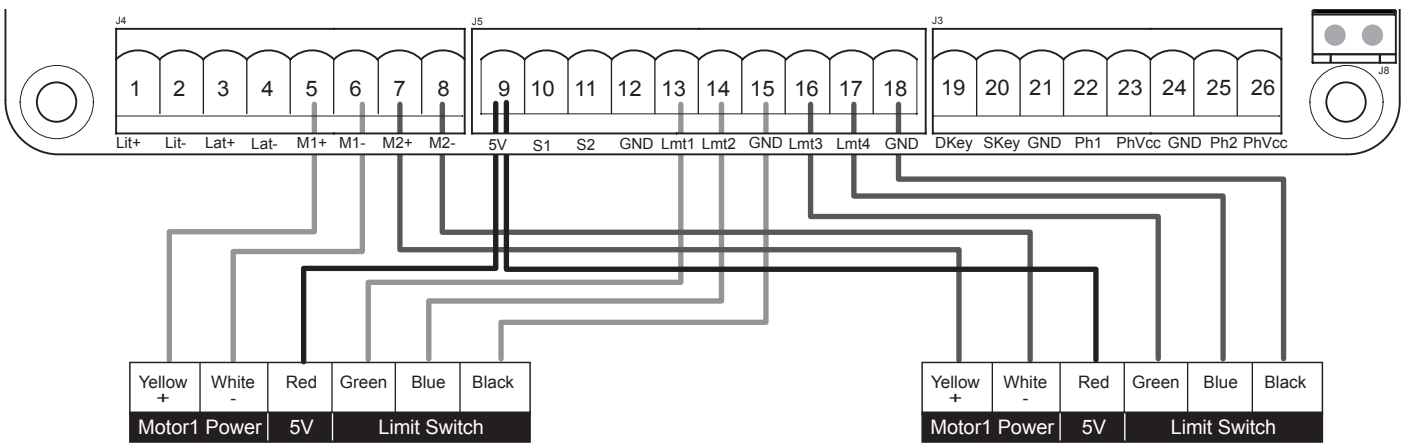

2.1.3 Motor With Hall Sensor

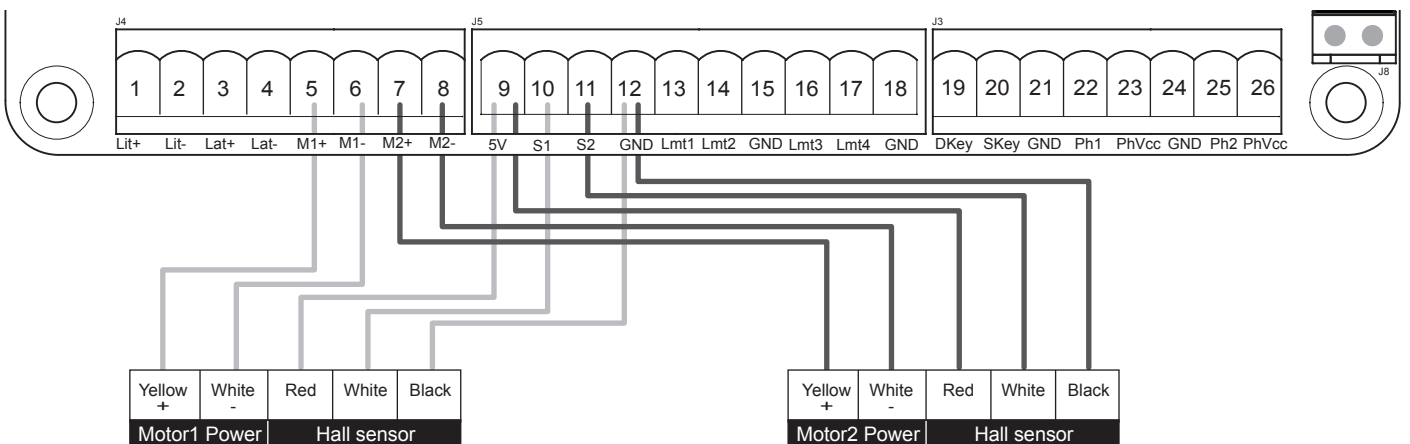

2.2 Back-up Batteries

Battery Power: The battery white connector must be fitted the correct way round (positive red to +positive) or you will short circuit the control board. There are 2 x 12v batteries fitted under the control board. They are connected together in series to make 24vDC via a black cable with a yellow fuse with positive of one battery to negative of second battery. The remaining positive and negative terminals go to the control board as per the photo above

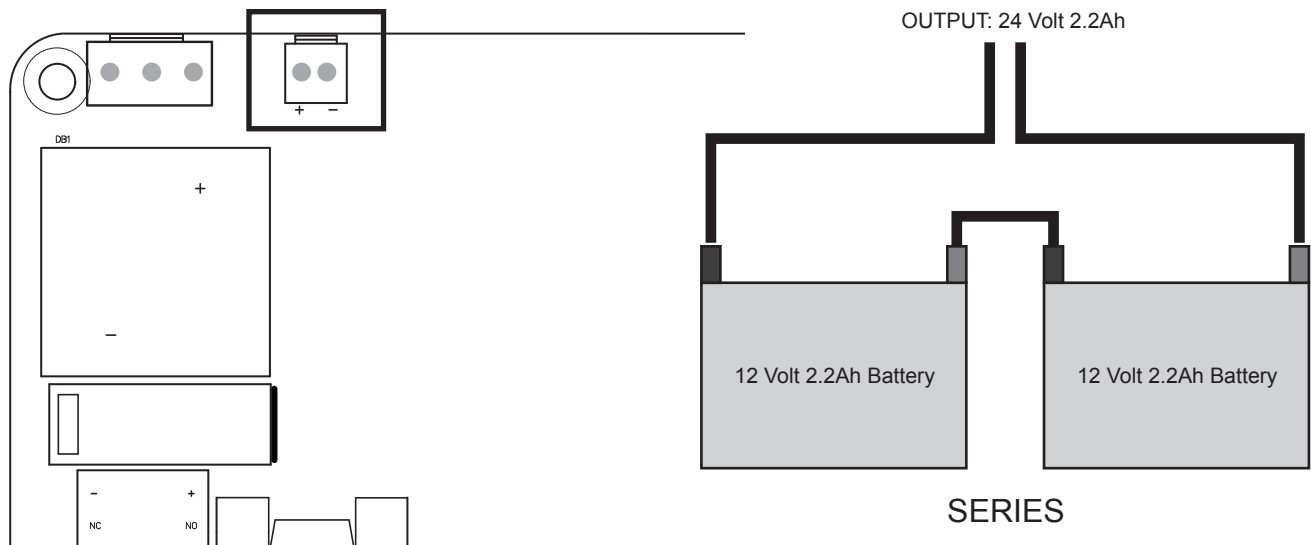

2.3 Accessories

2.3.1 Photocells

The safety photocells are security devices for control automatic gates. Consist of one transmitter and one receiver based in waterproof covers; it is triggered while breaking the path of the beams.

SPECIFICATION:

Detection Method	Through Beam
Sensing Range	25M
Input Voltage	AC/DC 12~24V
Response Time	100MS
Emitting Element	IR LED
Operation Indicator	Red LED(RX): ON(When Beam is Broken), Green(TX):ON
Dimensions	96*45*43mm
Output Method	Relay Output
Current Consumption Max	TX: 35MA/Rx: 38MA (When beam aligned properly); TX: 35MA/ Rx: 20MA (When beam is broken)
Water Proof	IP54

Figure 1(5)

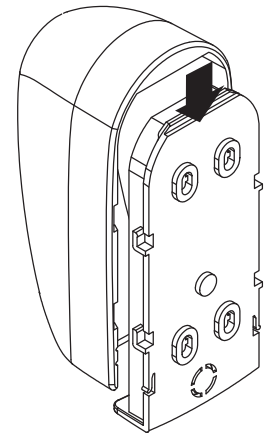

INSTALLATION:

Wire Connection of Photocells

TX: Connect terminals 1 and 2 on the transmitter with the terminals GND and PhVcc on the PC190 PCB.

RX: Connect terminals 1,2 and 4 on the receiver with the terminals GND, PhVcc, and Ph1/Ph2 on the PC190 PCB. And use an extra wire to connect terminals 2 and 5 on the receiver as a bridge.

Figure 1(6)

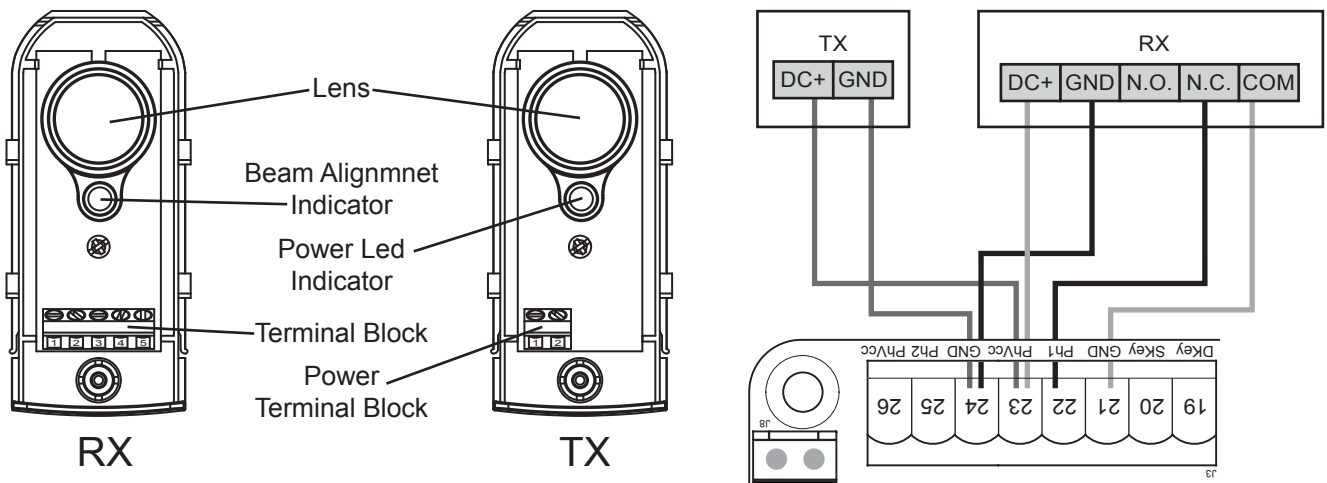
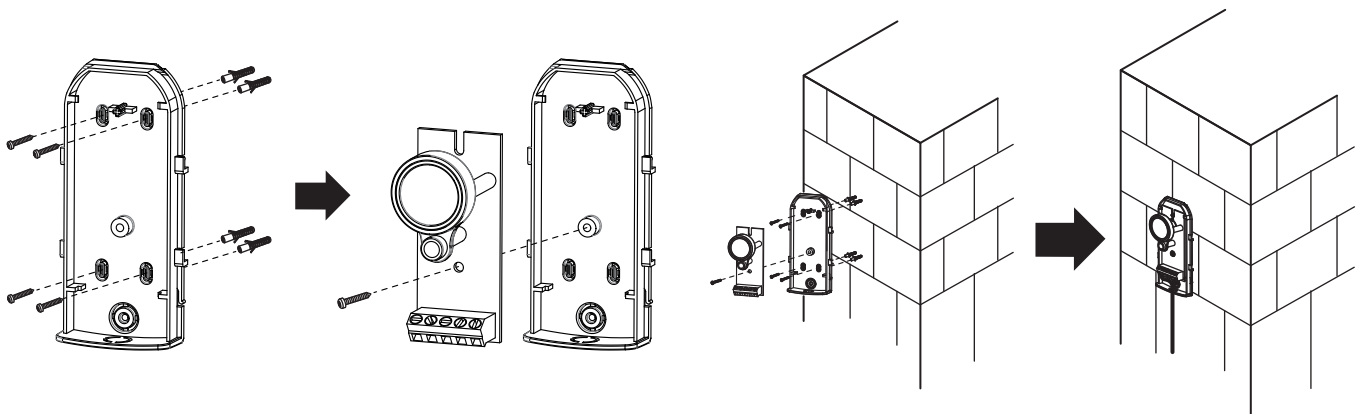
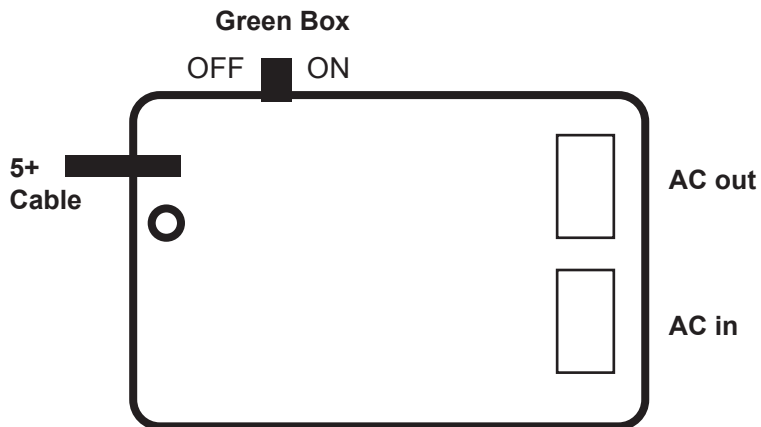

Figure 1(7)



2.3.2 Green Box

Green Box is for purpose when gate opener is in standby mode to allow it enter the power saving mode.



Installation manner:

AC IN: connect the electricity

AC OUT: connect the power of gate opener, and connect the transformer

5V CABLE: connect 3 pins white socket of control board

Please make sure the switch of Green Box is off before proceeding the system learning and installation of device. Wait for the system learning and installation of device to be completed, power on the Green Box

Gate opener will enter power saving mode without receiving any instruction in 1 min, and red LED light on Green Box will be activated. Gate opener start the operation, red LED light and power saving mode will turn off.

CAUTION:

In case of loop or installation of photocell which need power consumption anytime, please do not install Green Box.

3). Get Started

Note:

(A) Transmitter memorizing must be done first before system learning.

(B) CHECKING THE Gate MOVEMENTS

- 1) Release the gearmotor with the release key and move the gate to the middle so that it is free to move in both opening and closing directions; then lock the gearmotor.
- 2) Perform the gate opening and closing several times and make sure the gates touches the limit switch at least 2~3 cm before the mechanical stop.

3.1 Step 1: Remote Memorizing

3.1.1 Memorizing

(A) Transmitter Memorizing: Press and hold the “RF-LEARN” button the PCB for 1 second and when the blue LED on the RF board will be “ON”. Then press button A on the remote to memorize. The blue will be stay on for 8 second, within the 8 seconds you can multi-memorize new remotes by press the button A.

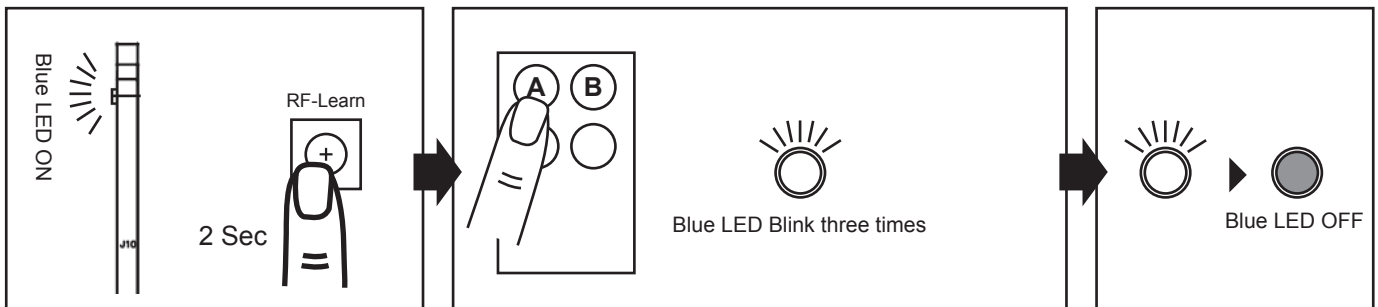

(B) Memorizing the remote after motor setup and installation have been completed without opening the control box and reaching the control panel: Press and hold the button A and B together for 8 seconds on the memorized remote, then press the button A on the new remote to memorize to the control. You can install a flashing light or open up the Buzzer FF-1 function on for indication.

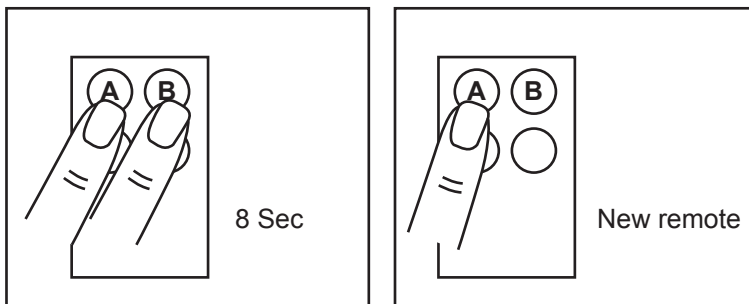

3.1.2 Erasing

Transmitter Memory Erasing: Press and hold the “RF-LEARN” button on the PCB for 10 seconds until blue LED off.

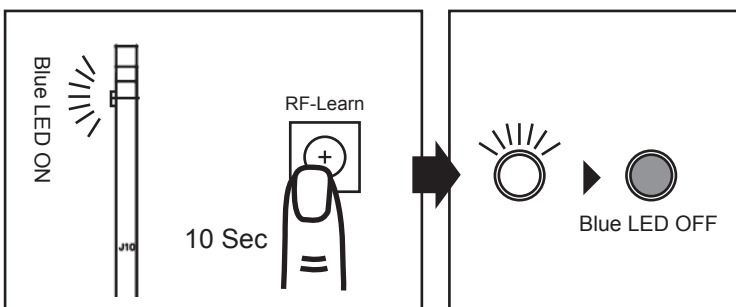

Note: One radio receiver can be memorized with 200 pcs of transmitter.

3.2 Step 2: System Learning

Step1:

Connect the master motor wires to M1 terminals and the slave motor wires to M2 terminals correctly. If only one gate is installed, the motor wires have to be connected to M1 terminals.

Note: Please check the parameter setting of “FK”(Dual/Single) before going into system learning.

Step2:

Press and hold the “UP+SET” button on the PCB for 5 seconds. The LED display will show “LEA” and process the system learning automatically, do not interrupt this procedure by pressing the remote or stop the gate, once completed the LED display will show “D-G” for dual gate or “S-G” for single gate according to the installation as complete of the system learn procedure.



In system learning mode, the gates will proceed with the following procedures.

A. Dual Gate:

- (1) Slave Gate Close → (2) Master Gate Close → (3) Master Gate Open →
 (4) Slave Gate Open → (5) Slave Gate Close → (6) Master Gate Close

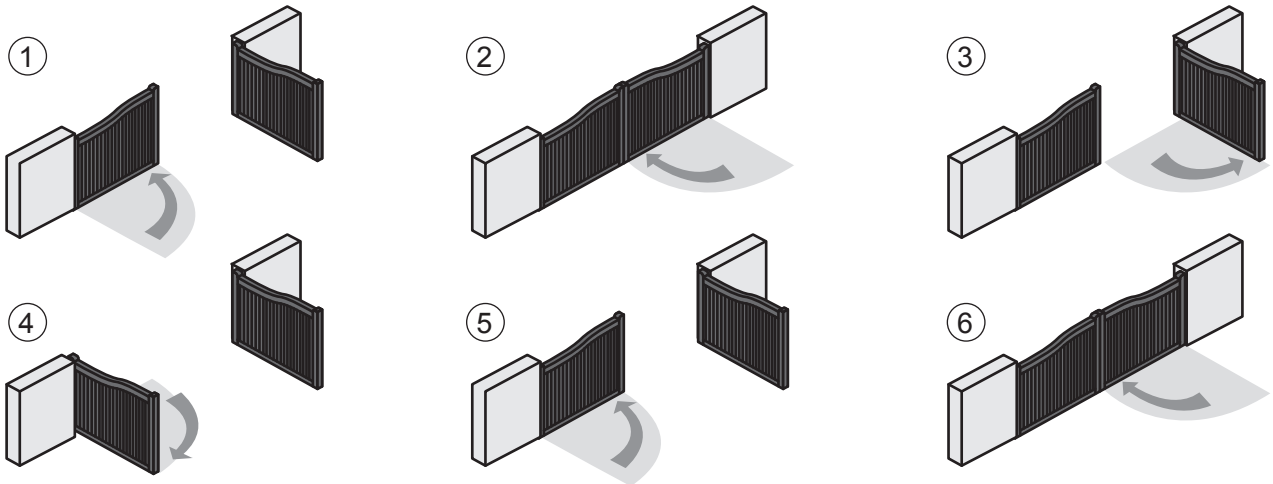

B. Single Mode :

- (1) Master Gate Close → (2) Master Gate Open → (3) Master Gate Close

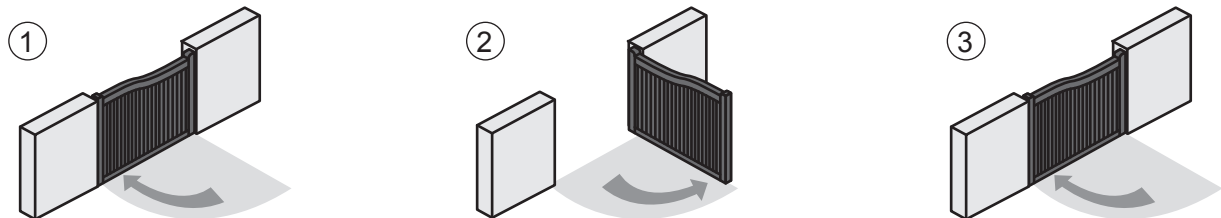

3.3 Testing

Press the button “A” for fully open, the “B” button for Pedestrian.
 (Partial opening)

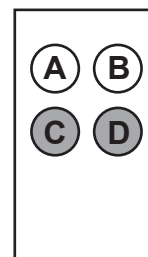

4). Gate Operation Logic

- (A) In gate-opening phase: The gates stop if the transmitter/push button/key selector is activated, and close when the transmitter/push button/key selector is reactivated.
- (B) In gate-closing phase: The gates stop if the transmitter/push button/key selector is activated, and open when the transmitter/push button/key selector is reactivated.

5). Safety For Gate Operation

- In gate-opening phase: For safety purpose, the gates stop if encountering obstacles.
- In gate-closing phase: For safety purpose, the gates reverse for 2 sec if encountering obstacles.

6). LED Indication

6.1 LED Lighting

Blue LED System Learning: Blue LED in receiver board blinks two times when learning is completed.

LED2 RF : Key selector, or the push button is activated, LED2 will be on.

LED4 Ph1 : LED4 will be on when Ph1 are triggered.

LED3 Ph2 : LED3 will be on when Ph2 are triggered.

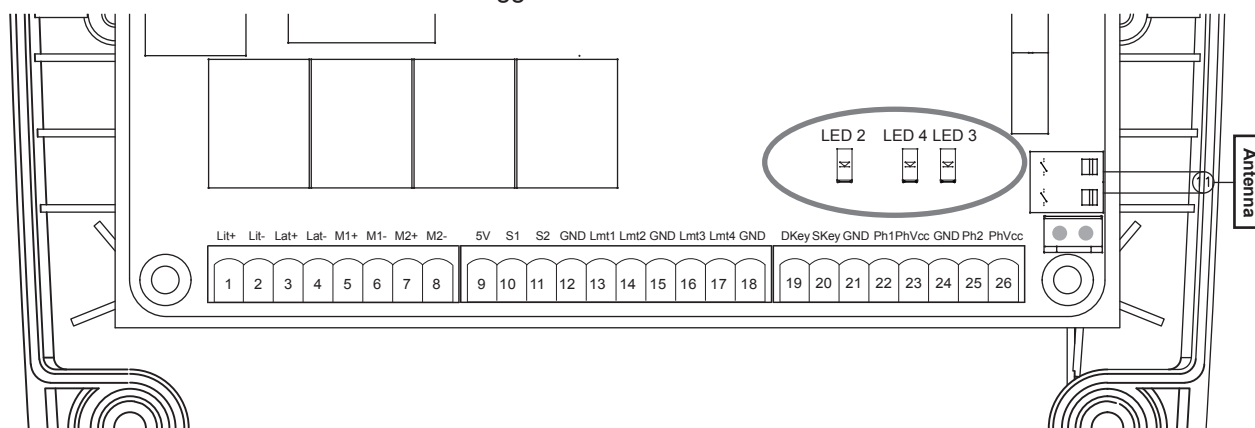

6.2 Function of the LED display

LED Display	Programmable Functions
	[LEA] means motor into the system learning mode, do not do not interrupt during this procedure
	[D-G] means motor completed the learning procedure for dual gate installation
	[S-G] means motor completed the learning procedure for single gate installation
	The memory of the system is all deleted/cleaned by press and hold the UP + SET+ DOWN button together for 5s and the panel will be back to default settings
	The motor is operating to open direction

LED Display	Programmable Functions
	The motor is stopped
	The motor is operating to close direction
	LED display shows "S01" means the panel did not detected the M1+/M1 and M2+/M2 both been connected before the system learning procedure, check for 2 motors' wire connection, for dual gate system
	LED display shows "S02" means the panel did not detected the M1+/M1 but detected M2+/M2 been connected, notice the installer to check the motor wire connection, if this is single gate system, motor wire should connect to M1+/M1 not on M2+/M2
	LED display show "S03" means same button on the remote has been identified for more than 2 functions

7). Parameter Modification

7.1 Parameter Learning

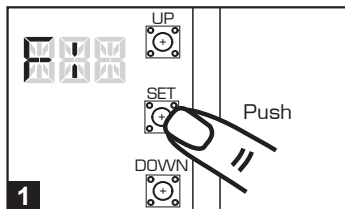

Press "SET" for 3 seconds to get into the program setting display from F1.

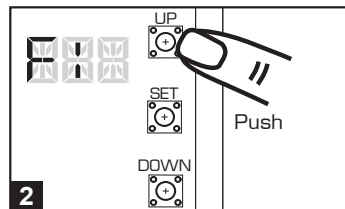

Press "UP" or "DOWN" to change setting item from F1 to FK .

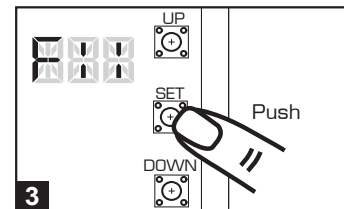

Press "SET" button again to get into the sub-settings

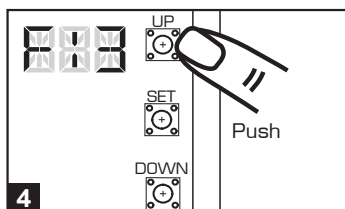

Press "UP" or "DOWN" to change Push from F1-1 to F1-3.

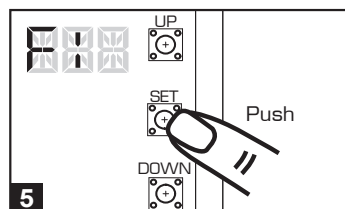

Press "SET" button again to confirm.

7.2 Parameter

Adding motor speed and over-current setting can be adjustable on OPEN/CLOSE

LED Display	Definition	Parameter	Table	Description
F1	Motor Type	F1-1 F1-2 F1-3	Motor only Motor with Limit Switch Motor with Hall Sensor	1. The factory setting is "F1-1"
F2	Over current setting for opening (For F1 setting is F1-1 Motor only / F1-2 Motor with Limit Switch)	F2-1 F2-2 F2-3 F2-4	2A 3A 4A 5A	1. For F1 setting is F1-1 Motor only / F1-2 Motor with Limit Switch 2. The factory setting is "F2-2"
	Over current setting for opening (Only for F1-3 motor with Hall Sensor)	-	0.5 – 4.0 A	1. For F1 setting is F1-3 Motor with Hall Sensor 2. Please refer to Note on page 11 for more instruction
F3	Over current setting for closing (For F1 setting is F1-1 Motor only / F1-2 Motor with Limit Switch)	F3-1 F3-2 F3-3 F3-4	2A 3A 4A 5A	1. For F1 setting is F1-1 Motor only / F1-2 Motor with Limit Switch 2. The factory setting is "F3-2"
	Over current setting for closing (Only for F1-3 motor with Hall Sensor)	-	0.5 – 4.0 A	1. For F1 setting is F1-3 Motor with Hall Sensor 2. Please refer to Note on page 11 for more instruction
F4	Motor speed for opening	F4-1 F4-2 F4-3	100% Full speed 80% Full speed 60% Full speed	1. The factory setting is "F4-2".
F5	Motor speed for closing	F5-1 F5-2 F5-3	100% Full speed 80% Full speed 60% Full speed	1. The factory setting is "F5-2".
F6	Deceleration speed for opening/closing	F6-1 F6-2	70% Full speed 50% Full speed	1. The factory setting is "F6-2".
F7	Open delay of dual gate operation adjustment	F7-0 F7-1 F7-2 F7-3 F7-4 F7-5 F7-6 F7-7 F7-8 F7-9	0 sec 2 sec 3 sec 4 sec 5 sec 6 sec 7 sec 8 sec 9 sec 10 sec	1. The factory setting is "F7-1".

LED Display	Definition	Parameter	Table	Description
F8	Close delay of dual gate operation adjustment	F8-0 F8-1 F8-2 F8-3 F8-4 F8-5 F8-6 F8-7 F8-8 F8-9	0 sec 2 sec 3 sec 4 sec 5 sec 6 sec 7 sec 8 sec 9 sec 10 sec	1. The factory setting is "F8-1".
F9	Auto-Close time adjustment	F9-0 F9-1 F9-2 F9-3 F9-4 F9-5 F9-6 F9-7 F9-8	OFF 3 sec 10 sec 20 sec 40 sec 60 sec 120 sec 180 sec 300 sec	1. Auto-close mode activates when the gates move to the end position or stopped manually. If the transmitter, push button, or the key selector is activated before the auto-close counting, the gate will close immediately. 2. The factory setting is "F9-0".
FA	Photocell function mode	FA-1 FA-2 FA-3 FA-4	Mode 1 Mode 2 Mode 3 Mode 4	1. Please see 7.3 photocell adjustment for photocell logic 2. The factory setting is "FA-1".
FB	Pedestrian Mode function (Partial opening)	FB-0 FB-1	Function OFF Function ON	1. When function on and push B key in the transmitter, one gate will open partially. 2. The factory setting is "FB-1".
FC	Pre-Flashing function	FC-0 FC-1	Function OFF Function ON	1. When function ON, the light will flash for 3 seconds before the gate operates. If set OFF, the flash light will operate with motor at the same time. 2. The factory setting is "FC-0".
FD	Photocell 1 function	FD-0 FD-1	Function OFF Function ON	1. The factory setting is "FD-0".
FE	Photocell 2 function	FE-0 FE-1	Function OFF Function ON	1. The factory setting is "FE-0".
FF	Buzzer function	FF-0 FF-1	Function OFF Function ON	1. The factory setting is "FF-1".
FG	Latch release	FG-0 FG-1	Release OFF Release ON	1. If the function ON, the motor will be reversed for 0.25 sec. to release the tension. 2. The factory setting is "FG-1".
FH	Open-Stop-Close-Stop function key	FH-1 FH-2 FH-3 FH-4	A Key B Key C Key D Key	1. The factory setting is "FH-1". 2. FH/FI/FJ can not select the same button
FI	Pedestrian Mode function key (Partial opening)	FI-0 FI-1 FI-2 FI-3 FI-4	Function OFF A Key B Key C Key D Key	1. The factory setting is "FI-2". 2. FH/FI/FJ can not select the same button
FJ	Manually turn ON / OFF Auto-Close time function key	FJ-0 FJ-1 FJ-2 FJ-3 FJ-4	Function OFF A Key B Key C Key D Key	1. The factory setting is "FJ-0" 2. FH/FI/FJ function can not be the same button 3. The manually turn ON / OFF Auto-Close time function key works only when the gate stops or on the open/close limit position.
FK	Dual/Sing Gate	FK-1 FK-2	Single gate Dual gate	1. The factory setting is "FK-2".

Note(F2/3 over-current setting in Hall sensor mode):

Only in "F1-3" Hall sensor mode, the PCB will record all the current value in learning mode. Please adjust over current value by setting F3 function after learning mode.

The recorded current values will increase according to the value shown on LED display as over current value.

The value can be adjusted by pressing button UP and DOWN. The maximum value is 40(4.0A) and the minimum value is 05(0.5A).
LED display example:



Indicate 1.0 ampere: all of the recorded values will increase 1 ampere as over current value.



Indicate 2.8 ampere: all of the recorded values will increase 2.8 ampere as over current value.



Indicate 0.6 ampere: all of the recorded values will increase 0.6 ampere as over current value.

7.3 Photocell Logic

FA-1 Photocell OPEN/CLOSE (Standard set up)

Position of Gate	When safety devices are activated	
Type of Safety Device	PH1 Photocell-CLOSE	PH2 Photocell-OPEN
FULLY CLOSED	No effect	Open not allowed
FULLY OPENED	Reload automatic closing time	No effect
STOP DURING MOVING	Reload automatic closing time	Open not allowed
CLOSING	Open	No effect
OPENING	No effect	Close

FA-2 Safety Edge

Position of Gate	When safety devices are activated	
Type of Safety Device	PH1 Photocell-CLOSE	PH2 Safety Edge
FULLY CLOSED	No effect	Open not allowed
FULLY OPENED	Reload automatic closing time	
STOP DURING MOVING	Reload automatic closing time	OPEN/CLOSE not allowed
CLOSING	Open	Reverse to open for 2 seconds
OPENING	No effect	Reverse to close for 2 seconds

FA-3 Open Only Device (Vehicle detector)

Position of Gate	When safety devices are activated	
Type of Safety Device	PH1 Photocell-CLOSE	PH2 Opening Device
FULLY CLOSED	No effect	Open
FULLY OPENED	Reload automatic closing time	
STOP DURING MOVING	Reload automatic closing time	Open
CLOSING	Open	Open
OPENING	No effect	No effect

FA-4 Double photocell set up

Position of Gate	When safety devices are activated	
Type of Safety Device	PH1 Photocell-CLOSE	PH2 Photocell-OPEN/CLOSE
FULLY CLOSED	No effect	Open not allowed
FULLY OPENED	Open for 2 seconds, when auto closing is ON	Close not allowed
STOP DURING MOVING	Close not allowed	Open not allowed
CLOSING	Open	No effect
OPENING	No effect	Stop

8) .Trouble Shooting

Issue:	Solution:	Parts to look at:
No power on the board.	<ul style="list-style-type: none"> - Power to the transformer is on and the connector block from the AC power lead to the transformer and to the control board is wired correctly. - At the control board check the transformer white connector blocks are correctly plugged into board and the battery connector if equipped. - Check fuses are both working. * 15amp for stand-alone transformer. - Check there is 24vac into and out of the Control box fuse. - The batteries are connected to the control board and read higher than 24vdc if equipped. - Try removing optional extras such as beams and probes to see if they are draining the power. And reset the control panel to default and testing the motor operation 	<ul style="list-style-type: none"> - Fuse - Transformer power - Loose wires - Incorrect wire contact at connector blocks - Short circuit in wiring between transformer and board - Battery
A single arm activation isn't working.	<ul style="list-style-type: none"> - Check function setting are set correctly for single arm. FK-1 single gate mode. FB-1 Pedestrian mode to be ON. Using button B on the remote to operate the single gate. - Make sure the arm is connected to motor 1 and not motor 2. - Your remote is programmed in. - You have done a systems learn. - There is adequate power going to the board. 	<ul style="list-style-type: none"> - Motor connection - Function setting for single mode
Remotes or wireless keypad not working.	<ul style="list-style-type: none"> - Re-program remotes by pressing the RF learn button until a blue light next to it comes on. Press the remote ONCE and it should flicker. Now wait until the light goes off and try again. - You can program in several remotes or devices at a time however all signals need to be sent before the blue light goes off again. - Push the button fairly solid and hold it in for a whole second. The blue light should flicker. - When programming remotes press the top left button ONLY. The rest of the buttons will program themselves in with it. Use the function FH & FI to command the remote. - If the blue light is on continuously without pressing the RF learn button it means the receiver is faulty and needs to be replaced. - The blue light will still flash when a remote that has not been programmed in is used. It will however not activate. - Reset the keypad. Do this by flicking off the front cover with a small screw driver. Undo the 2 nuts, turn over and repeat until left with the control board on the casing. Undo the 3 screws in the corner. Turn over the circuit board and there is a button there. Hold it until you hear a beep. Try keypad again and reassemble. 	<ul style="list-style-type: none"> - RF Learn button on control board
Lights on the board but arm(s) not moving.	<ul style="list-style-type: none"> - Check that the battery is 24V+. - Make sure your connections aren't loose. - The power input is feeding in 24V+. - The gate is free from any obstructions. - The arm is locked into place (A good way to test this is if you can move the gate freely, then it won't work via the motors). - Ensure a systems learn has been done from start to finish. - You have correctly wired the wires from the rams to the control box. 	<ul style="list-style-type: none"> - The gate - Power sources - Arm wires.
Blue light stays on permanently	<ul style="list-style-type: none"> - Ensure you have waited the full 10 seconds. - Try depowering and repowering the board. - If it still keeps glowing please call or email us. Receiver may need replacement. 	
Gates remain open after systems learn/one arm stays open and the other one closed.	<ul style="list-style-type: none"> - Ensure you have matched the + and - of each ram to the equivalent + and – motor symbols on the board. - Change the polarity connection of the positive(+) with the negative(-) of the motor if the gate both stay open instead of close after the system learning - Clear any obstructions to the gates. - Make sure that the arms are going no further than 100 degrees. - The function setting should be set for a double swing and not a single. - Check the LED display during the system learning showing the motor current, once the reading is too high check the installation or the gate condition . - Ensure the motors are locked in. - Increase the power amp settings by function setting F2 for open and F3 for close direction (mentioned above). 	
Gates not fully opening or closing	<ul style="list-style-type: none"> - Ensure there is nothing obstructing the gate or the arms. - If the gate is a bigger or heavier gate change the power settings using the F2 for open and F3 for close direction. You should not have to use the maximum power setting. This is intended for a 500kg double swing gate (or 250kg single). - Re-do the systems learn. 	
One gate opens part of the way/not at all.	<ul style="list-style-type: none"> - Make sure you are pressing the top left hand button. The other buttons do have their individual functions. - Check the FB function for pedestrian mode, set to FB-0 if you require the single gate to be fully open instead of partial open - Both arms are wired onto the control board correctly. They should be identical. I.E. black, red. Black, red. 	
Remote/ keypad range is less than 20M	<ul style="list-style-type: none"> - Make sure the antenna is attached and screwed in on the control board. - Make sure there is nothing obstructing the antenna such as the power cable or motor cables. 	

9). Technical Specification

Main power supply	230Vac/110Vac, 50Hz/60Hz
Back-up battery	2pcs of batteries for emergency operation, 1.2A each
Receiver board	433.92MHz; 200 transmitters memory
Installation	Wall mounted vertically
Operating Temperature	-20°C~+50°C
Dimension	275mm * 195mm * 102mm



24V power supply
for great safety



Solid material apply
with lasting usage



Manual release device
with easy use and
highly protection



Worm gear application
give silence operation



Easy installation
and user friendly
interface