

BOXER SERIES SLIDING GATE OPENER

USER MANUAL

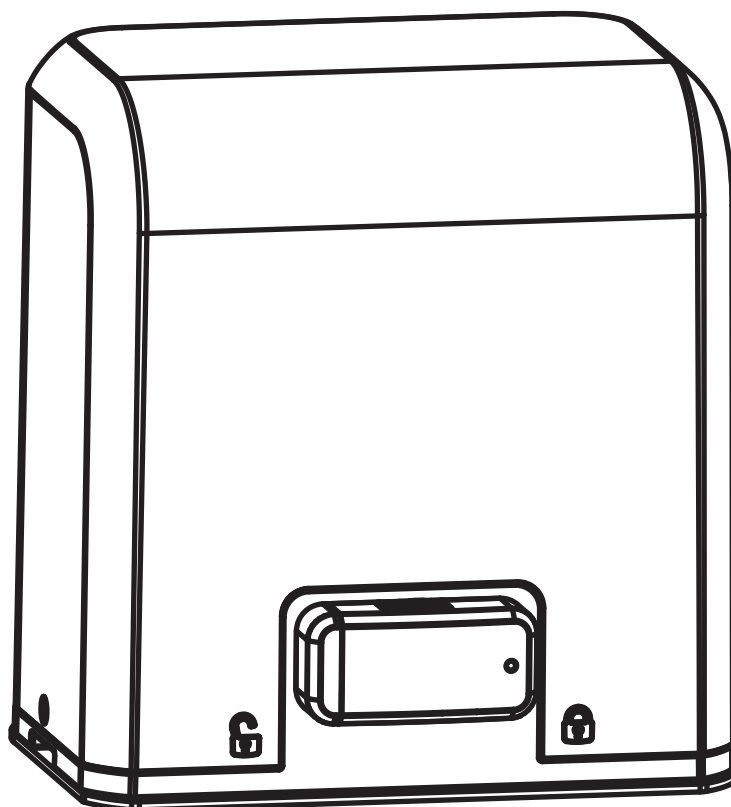

Reuse
Reduce
Recycle



INDEX

1. GENER SAFETY PRECUATION _____	P.2
2. INSTALLATION _____	P.3
2.1 STANDARD INSTALLATION DEMONSTARTION	P.3
2.2 DESCRIPTION OF DEVICE	P.3
2.3 DIMENSION OF DEVICE	P.4
2.4 INSTALLATION OF GEAR MOTOR AND GEAR RACK	P.4
2.5 CHECKING FOR INSTALLATION	P.5
2.6 EMERGENCY RELEASE	P.5
3. SETUP AND FUNCTION SETTING _____	P.6
3.1 WIRE CONNECTION	P.6
3.2 TRANSMITTER MEMORIZATION	P.7
3.3 SYSTEM LEARNING AND LED DISPLAY	P.7
3.4 PROGRAMMABLE FUNCTION SETTINGS	P.8
3.5 TESTING AND CHECKING	P.9
3.6 SW2/SW6 SETTING	P.10
4. TECHNICAL CHARACTERIESTICS _____	P.10
4.1 TENICAL DATA SHEET OF BOXER SERIES	P.10
4.2 H2 PHOTOCELL DATA SHEET	P.11
4.3 TM3 TRANSMITTER DATA SHEET	P.11
4.4 FL2 FLASHING LIGHT DATA SHEET	P.11
4.5 RB1 EXTERNAL RECEIVER BOX DATA SHEET	P.11
5. ADDITIONAL INFORMATION _____	P.12
5.1 WIRE CONNECTION OF H2 PHOTOCELL (SAFETY BEAM)	P.12
5.2 WIRE CONNECTION AND SETTING OF RB1 EXTERNAL RECIEVER BOX	P.13

1. GENERAL PRECAUTION:

WARNING :

This user manual is only for qualified technicians who is specialized in installations and automations.

- (1) All installations, electrical connections, adjustments and testing must be performed only after reading and understanding of all instructions carefully.
- (2) Before carrying out any installation or maintenance operation, disconnect the electrical power supply by turning off the magneto thermic switch connected upstream and apply the hazard area notice required by applicable regulations
- (3) Make sure the existing structure is up to standard in terms of strength and stability
- (4) When necessary, connect the motorized gate to reliable earth system during electricity connection phase.
- (5) Installation requires qualified personnel with mechanical and electrical skills.
- (6) Keep the automatic controls (remote, push bottom, key selectors...etc) being placed properly and away from children.
- (7) For replace or repair of the motorized system, only original parts must be applied. Any damage caused by inadequate parts and methods will not be claimed to motor manufacturer.
- (8) Never operate the drive if you have any suspect with what it might be faulty or damage to the system.
- (9) The motors are exclusively designed for the gate opening and closing application, any other usage is deemed inappropriate. The manufacture should not be liable for any damage resulting from the improper use. Improper usage should void all warranty, and the user accepts sole responsibility for any risks there by may accrue.
- (10) The system may only be operated in proper working order. Always follow the standard procedures by following the instructions in this installation and operating manual.
- (11) Only command the remote when you have a full view of the gate.

TMT AUTOMATION INC. shall not be liable for any injury, damage, or any claim to any person or property which may result from improper use or installation of this system.

Please keep this installation manual for future reference.

2. INSTALLATION:

2.1 STANDARD INSATLLATION DEMONSTARATION

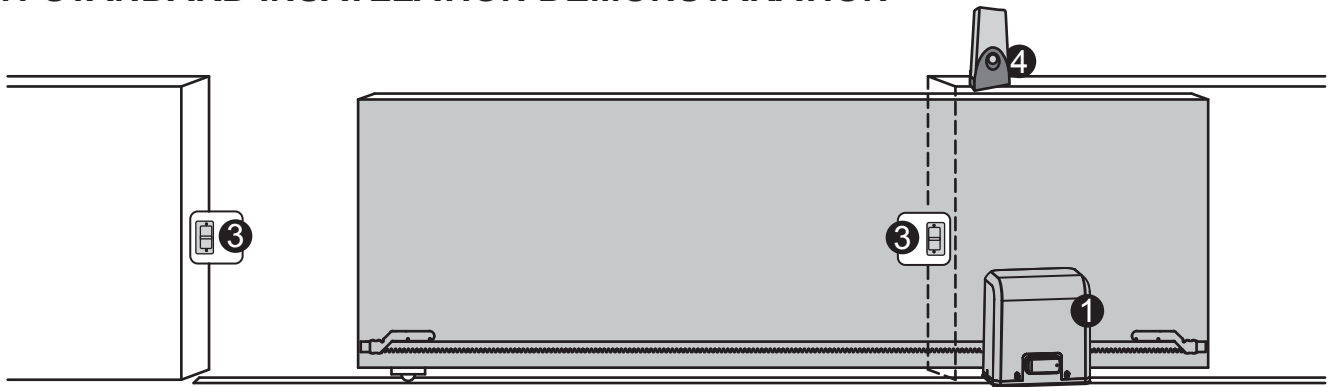

1. 24Vdc Sliding motor
2. Transmitter
3. safety photo Sensor
4. Flashing light

2.2 DESCRIPTION OF DEVICE

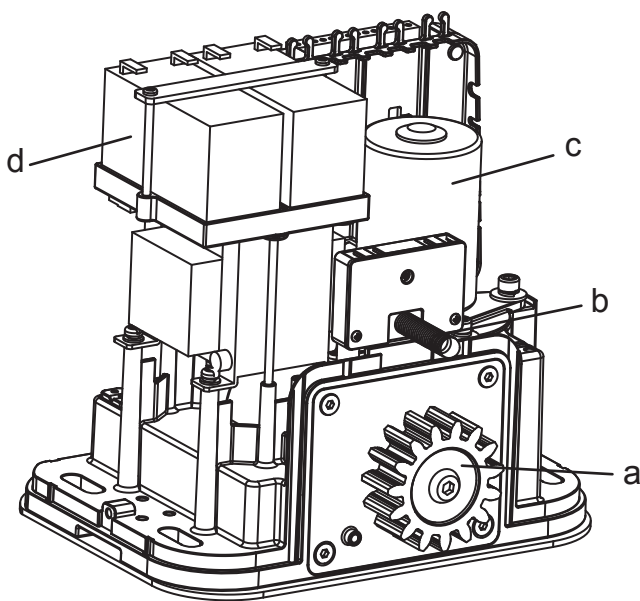

- a. Operation gear
- b. Limit switch device
- c. 24Vdc motor
- d. Back-up batteries

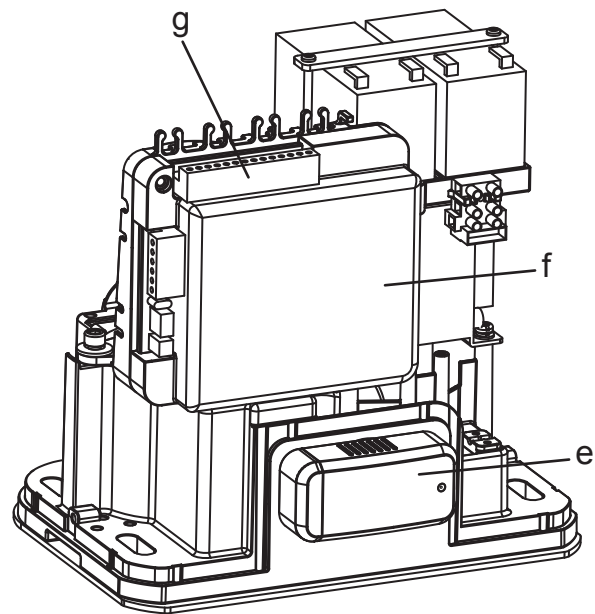

- e. Release device
- f. Control panel
- g. Terminals of devices

2.3 DIMENSION OF DEVICE

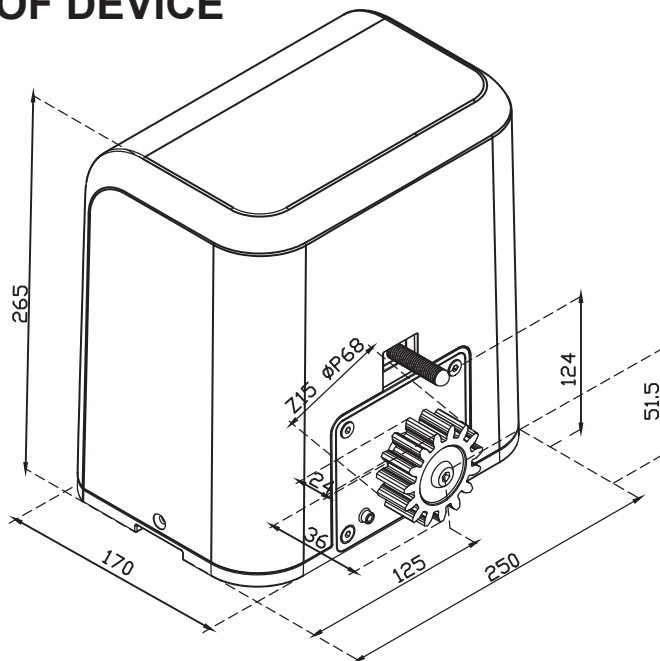

2.4 INSTALLATION OF MOTOR GEAR AND GEAR RACK

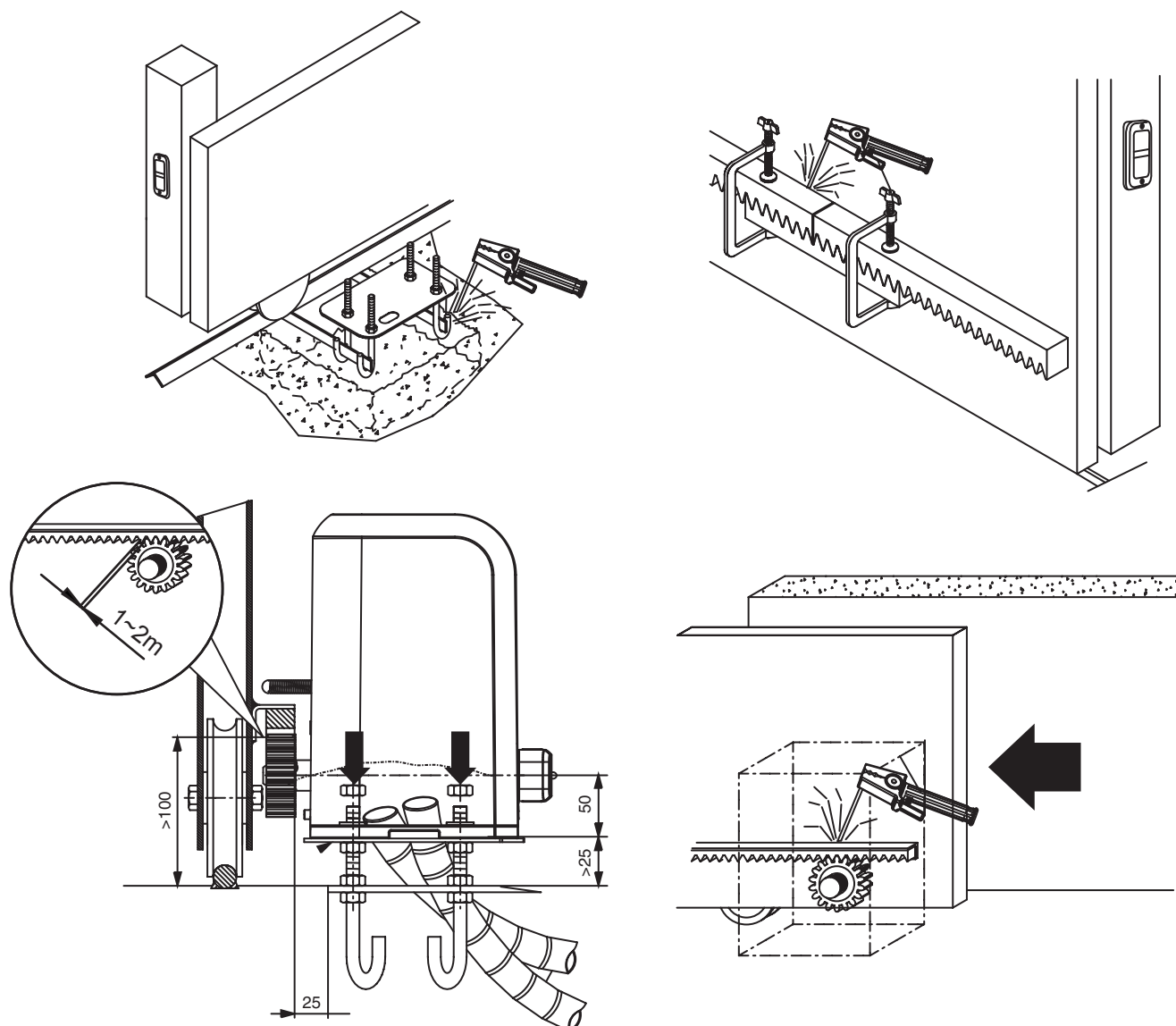

2.5 CHECKING FOR INSTALLATION

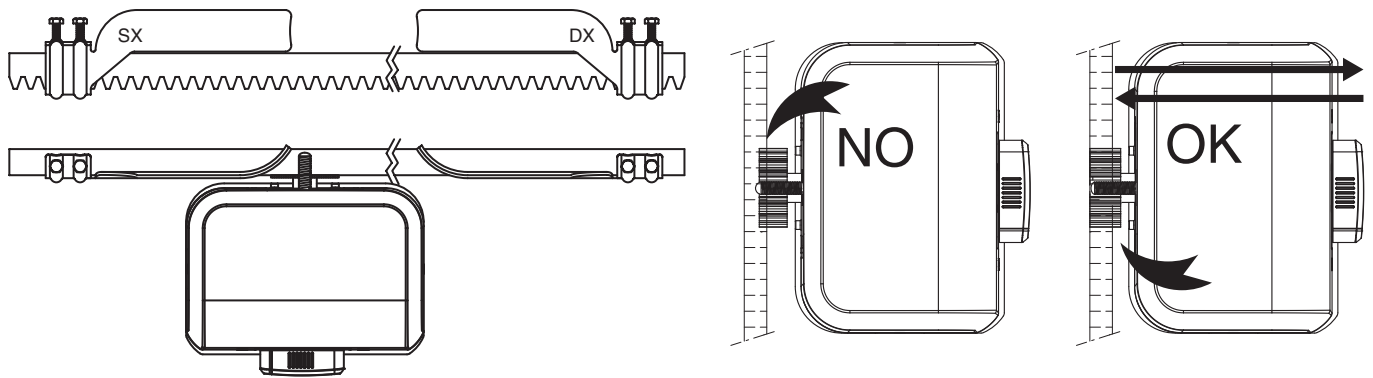

2.6 EMERGENCY RELEASE

In the case of power failure for emergency release of the motor, please follow the procedure as below:

- Step1.** Push the lid of release chamber and move rightward
 - Step2.** Insert the key and turn clockwise to unlock the device
 - Step3.** Turn counter-clockwise of the bar to release the motor
- To restore the automation, simply reverse the above procedure.

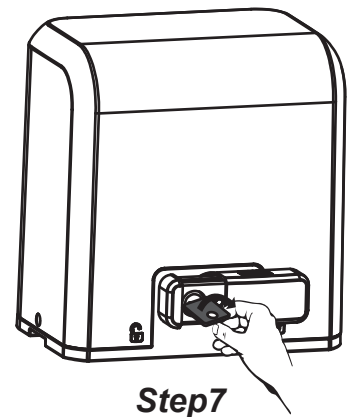
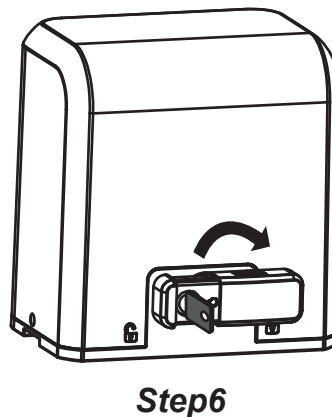
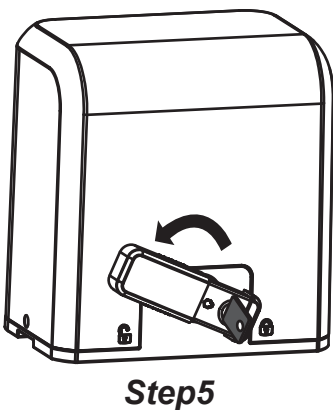
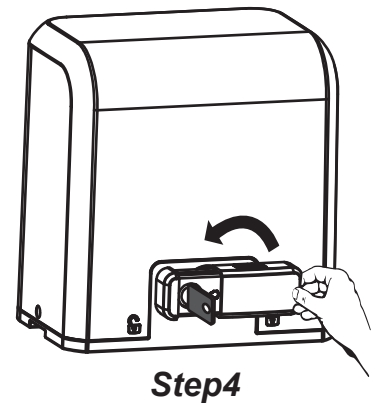
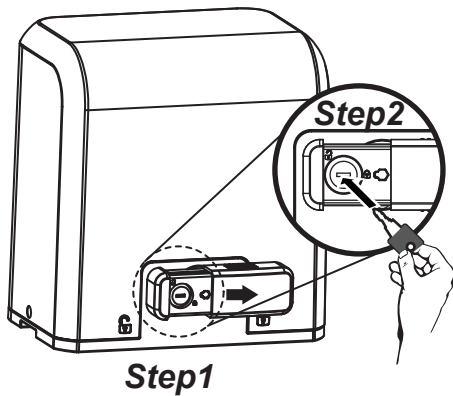
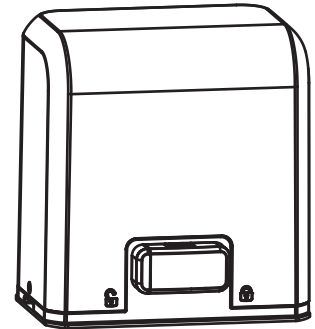

3. SETUP AND FUNCTION SETTING:

3.1. WIRE CONNECTION

If the Led display is in normal performing refer to “4.2.1”, you can control the gate by either transmitters or the button on the board: “UP”-clockwise moving, “SET”- stop and “DOWN”- Counterclockwise moving.

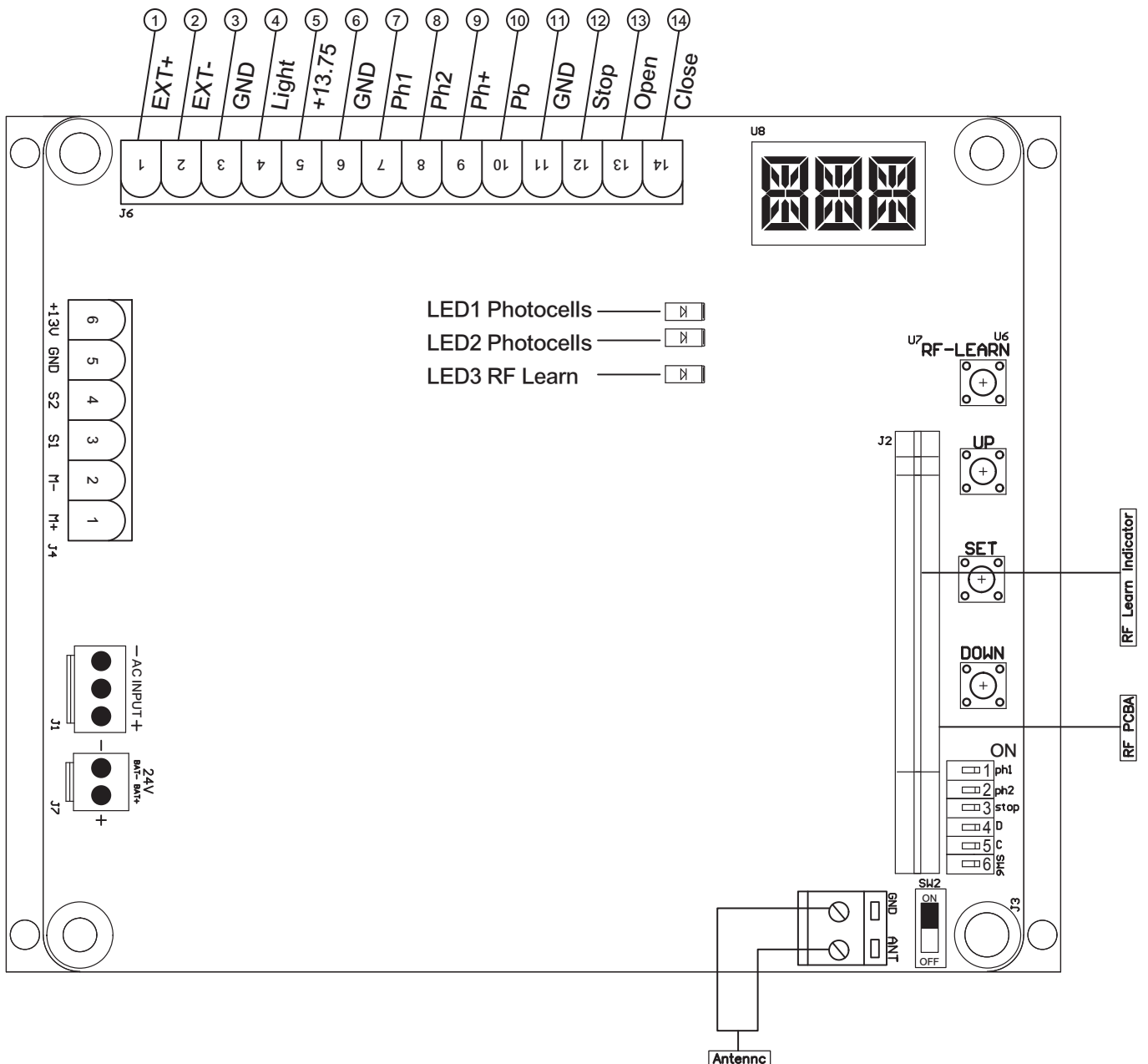
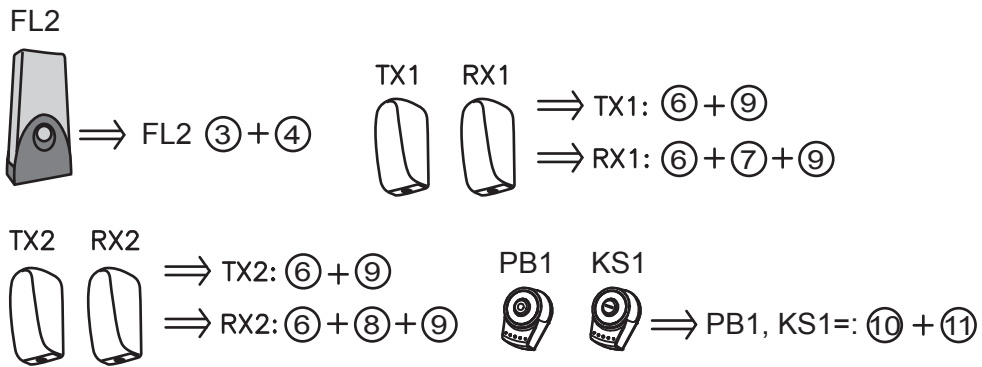

3.2 TRANSMITTER MEMORIZING

Press “RF-learn” button for 2 seconds, and the Blue LED will be on; then press the transmitter (A) button; The Blue LED will blink twice and stay on for 10 seconds then be off. And the remote memorize has completed.

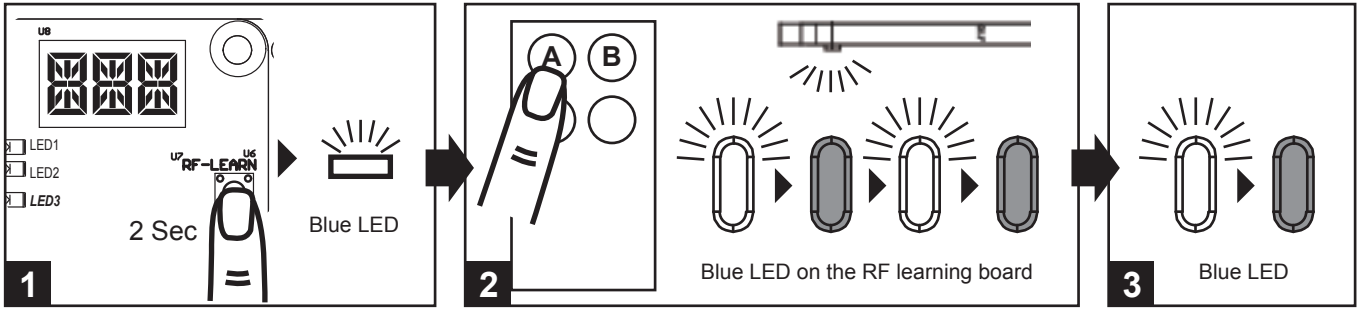

3.3 SYSTEM LEARNING AND LED DISPLAY

! CAUTION: Before proceeding to system learning, the transmitter memorizing process has to be completed.

To complete the system learning, follow the instructions below:

- Step1:** Press “SET”; then press “SET” + “DOWN” for 3 seconds, and the LED display shows “LEA”
- Stop2:** Press button (A) on time, the LED display should shows “ARN”
- Step3:** The gate will goes to Auto-learning, please wait for the learning process to be completed

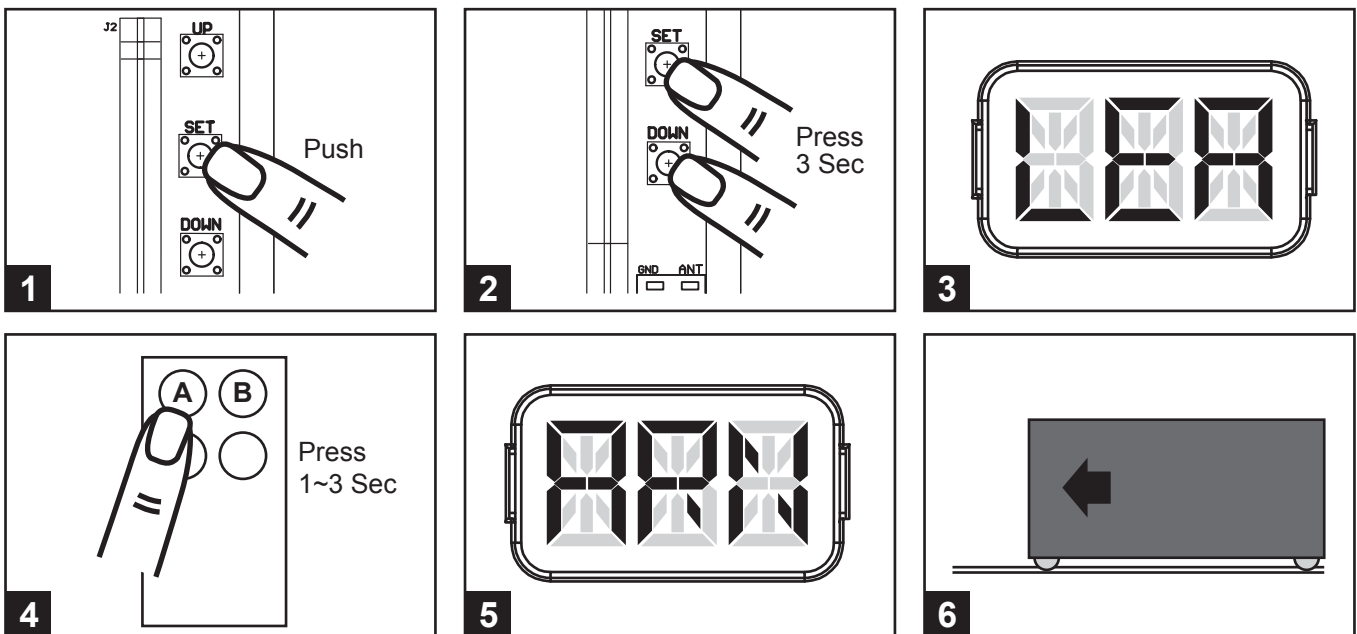

LED Display	Programmable Functions
	“N-L”: The Boxer system learning is not done.
	“RUN”: The Boxer system is in normal operation To program, press SET button for 3 seconds, when the LED display change from RUN to F1, press UP or DOWN to change function settings (F1 to FA). Then press SET to enter the sub function within each group, press UP or Down to select sub functions and press SET for confirmation.
	“LEA”: Enter learning mode and then wait for learning instructions.
	“ARN”: The system learning is in progress. The Auto-learning process of gate moving: “Gate open to the end- stop close to the end- stop.”

3.4 PROGRAMMABLE FUNCTION SETTINGS

LED Display	Definition	Function	Value	Description	
F1	Options of Gate Opening direction	F1-0	Clockwise Opening	1. The function can adjust the direction of gate opening. 2. The factory setting is "F1-1".	
		F1-1	Counterclockwise Opening		
F2	Automatic Closing	F2-0	No automatic closing		1. This function can cause the gate to close automatically after the paused time. 2. The factory setting is "F2-0": No automatic closing .
		F2-1	5 seconds		
		F2-2	15 seconds		
		F2-3	30 seconds		
		F2-4	45 seconds		
		F2-5	60 seconds		
		F2-6	80 seconds		
		F2-7	120 seconds		
		F2-8	180 seconds		
F3	The reactions of the photocells/ safety edge/ loop detector when they detecting obstacles	F3-1	Please refer to page 9, F3 settings		1. The factory setting is "F3-3".
		F3-2			
		F3-3			
F4	Motor Speed		Speed 1	Speed 2	1. The function can adjust the running speed of motor. 2. Speed 1: Motor full speed; Speed 2: Speed during learning mode (of full speed) 3. The factory setting is "F4-4."
		F4-1	50%	50%	
		F4-2	70%	60%	
		F4-3	85%	70%	
		F4-4	100%	80%	
F5	Motor Over Current Setting	F5-1	Light Heavy	1. The function can adjust the running force of motor to be compatible with the gate weight. 2. The factory setting is "F5-4". 3. The motor force value: F5-1: 2A F5-6: 7A F5-2: 3A F5-7: 8A F5-3: 4A F5-8: 10A F5-4: 5A F5-9: 13A F5-5: 6A 4. As over current setting	
		F5-2	Light Heavy		
		F5-3	Light Heavy		
		F5-4	Light Heavy		
		F5-5	Light Heavy		
		F5-6	Light Heavy		
		F5-7	Light Heavy		
		F5-8	Light Heavy		
		F5-9	Light Heavy		
F6	Pedestrian Mode	F6-0	3 seconds		1. The function can adjust the time of opening partially. 2. The factory setting is "F6-1". 3. Press button B on the remote to operate the pedestrian mode.
		F6-1	6 seconds		
		F6-2	9 seconds		
		F6-3	12 seconds		
		F6-4	15 seconds		
		F6-5	18 seconds		
F7	Pre-flashing	F7-0	The flashing light blinks when the gate starts to move.		1. The factory setting is "F7-0".
		F7-1	The flashing light blinks 3 seconds before the gate starts to move.		
F8	Deceleration point programming of total travel distance	F8-1	75%		1. The factory setting is "F8-4".
		F8-2	80%		
		F8-3	85%		
		F8-4	90%		
F9	Deceleration Speed	F9-1	100% System learning speed		1. The factory setting is "F9-4".
		F9-2	80% System learning speed		
		F9-3	50% System learning speed		
		F9-4	30% System learning speed		
FA	Auto - Reverse when object impacted	FA-0	No Auto - reverse		1. The factory setting is "FA-3".
		FA-1	1 second		
		FA-2	3 seconds		
		FA-3	Reverse to the end		

- F3 function settings:

Logic F3-1 The reactions of the photocells when detecting obstacles			
Gate Status	Photocell 2	Photocell 1	Photocell 1 / Photocell 2
Closed	Stop opening	No effect	Stop opening
Open	No effect	Reloads automatic closing time	
Stop during moving	Stop opening	Reloads automatic closing time	
Closing	No effect	Open	Locks and, on release, reverses to open
Opening	Closes the leaf	No effect	Locks and, on release, continues opening

Logic F3-2 The reactions of the safety edge/ photocell when detecting obstacles		
Gate Status	Safety Edge	Photocell 1
Closed	Stop opening	No effect
Open	Reloads automatic closing time	
Stop during moving	Stop opening/ closing	Reloads automatic closing time
Closing	Reverses to open for 2 seconds	Open
Opening	Reverses to close for 2 seconds	No effect

Logic F3-3 The reactions of the loop detector/ photocell when detecting obstacles		
Gate Status	Loop Detector	Photocell 1
Closed	Open	No effect
Open	Reloads automatic closing time	
Stop during moving	Open	Reloads automatic closing time
Closing	Open	Open
Opening	Open	No effect

- The position of safety devices:

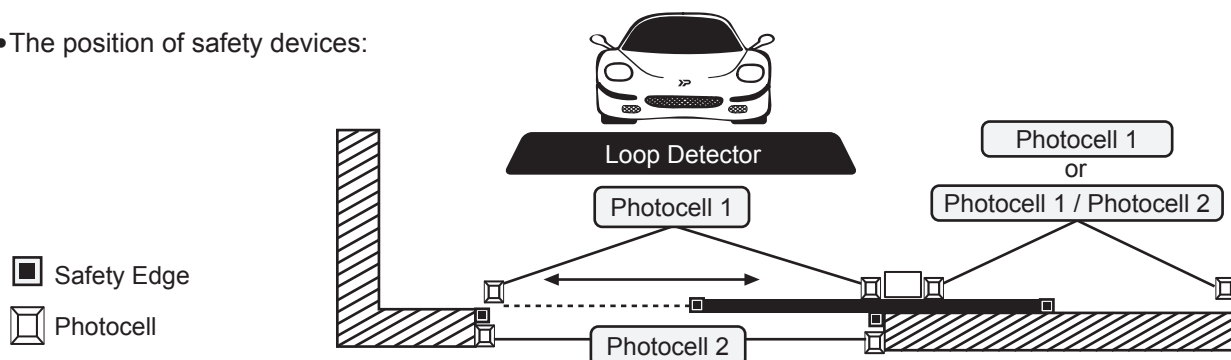

3.5 TESTING AND CHECKING

Make sure the notices included in 1.1 General safety precaution “WARNINGS” has been carefully observed.

- Release the gearmotor with the proper release key.
- Make sure the gate can be moved manually during opening and closing phases with a force of max. 390N (40 kg approx.)
- Lock the gearmotor.
- Using the Key selector switch, push button device or the radio transmitter, test the opening, closing and stopping of the gate and make sure that the gate is in the intended direction.
- Check the devices one by one (photocells, flashing light, key selector, etc.) and confirm the control unit recognizes each device.

3.6 SW2/SW6 SETTING:



	Default	Device	Description	Remark
SW6	1 – ON	Ph1 Photocell-1	Switch to ON if Ph1 is not connected; Otherwise, switch to OFF if Ph1 is connected	1 & 2 must switch to ON , if Ph1 & Ph2 are not connected to any devices
	2 – ON	Ph2 Photocell-2	Switch to ON if Ph2 is not connected; Otherwise, switch to OFF if Ph2 is connected	
	3 – ON	Stop	Switch to ON if “Stop (12)” is not connected; Otherwise, switch to OFF if “Stop” is connected to any device	
	4 – ON	Remote	Setting with SW2	
	5 – ON	Remote	Setting with SW2	
	6 – ON	None	No function	

	Default	Device	Description (coordinate with remote)	Remark
SW2	ON	2/4 Channel Transmitter	ON, Button B is pedestrian mode	With external device: SW6 4 - ON/OFF > Button C - ON/OFF; SW6 5 - ON/OFF > Button D - ON/OFF;
			If connected with external device (EXT+/EXT-; 1/2) , SW6 4-ON; Button C on the remote can operation the device	
			If connected with external device (EXT+/EXT-; 1/2) , SW6 5-ON; Button D on the remote can operation the device	
SW2	OFF	2/4 Channel Transmitter	OFF , Button B can operation the external device (EXT+/EXT-; 1/2)	If using a 2-channel remote and require the Button B to operation the external device , switch the SW2 to OFF
			OFF , SW6 4-ON; Button C is pedestrian mode; Button D no function	
			OFF , SW6 5-ON; Button D is pedestrian mode; Button C no function	

4. TECHNICAL CHARACTERISTICS:

4.1 TECHNICAL DATA SHEET OF BOXER SERIES

Motor	Boxer 500
Gear type	Worm Gear
Peak thrust	5500N
Nominal thrust	5000N
Engine RPM	3800 RPM
Absorbed Power	60W
Power supply	24 Vdc
Nominal input power	3A
Maximum gate weight	500kg
Maximum gate length	6 Meters
Maximum operating current	5.5A for Maximum 10 secs
Operating Temperature	-20°C~+50°C
Dimension LxWxH mm.	250 X 170 X 265
Weight	8 kg
Speed	21.9 cm / sec

4.2 H2 PHOTOCCELL DATA SHEET

Detection type	Through beam
Operating distance	30 meters
Response time	100ms
Input voltage	AC/DC 12~24V
Operating Temperature	-20°C~+60°C
Protection class	IP66
Dimension	59mm * 87mm * 38mm

4.3 TM3 TRANSMITTER DATA SHEET

Application	Radio transmitter
Frequency	433.92Mhz
Coding	Rolling code
Buttons	2, for single-gate or dual-gate operation
Power Supply	3V with one CR2032 button type lithium battery
Operating Temperature	-20°C~+50°C
Dimension	71.5mm * 33mm * 14mm

4.4 FL2 FLASHING LIGHT DATA SHEET

Application	For outdoor use
Installation	Wall mounted vertically
Operating Temperature	-20°C~+50°C
Dimension	85mm * 60.5mm * 40.5mm

4.5 RB1 EXTERNAL RECEIVER BOX DATA SHEET

Power Supply	12V ~ 24V ac/dc
Radio Frequency	433.92Mhz
Max. remote memorized	200pcs
Dimensions	106mm* 53mm* 20mm (L*W*H)
Output terminals	Output 1 & Output 2

5. ADDITIONAL INFORMATINO:

5.1 WIRE CONNECTION OF H2 PHOTOCELL (SAFETY BEAM)

Figure 5(1)

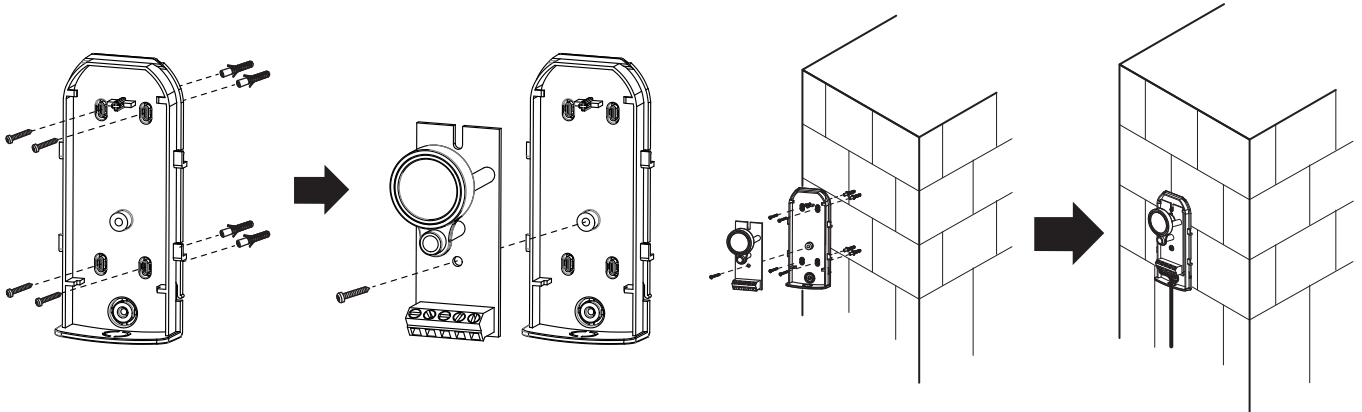

Figure 5(2)

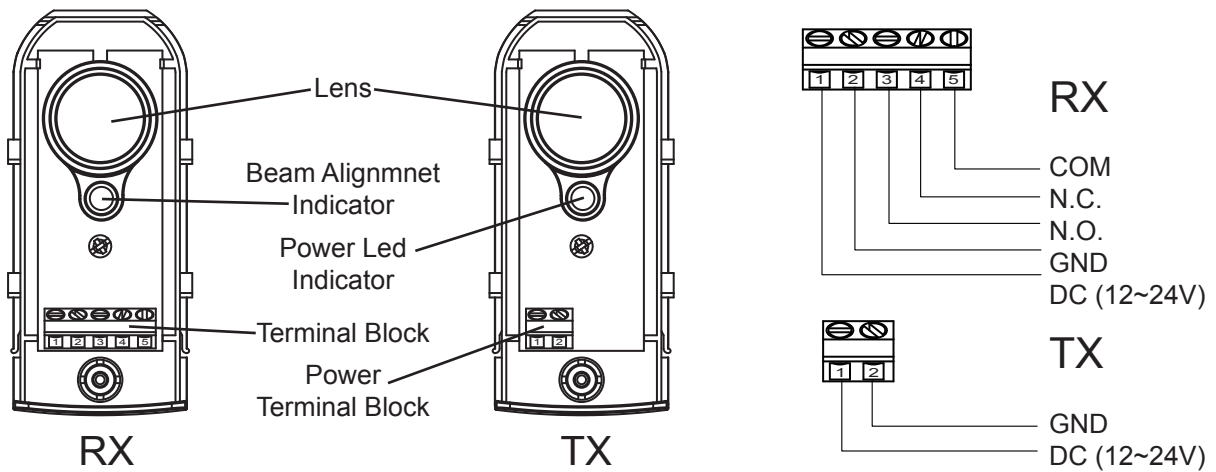
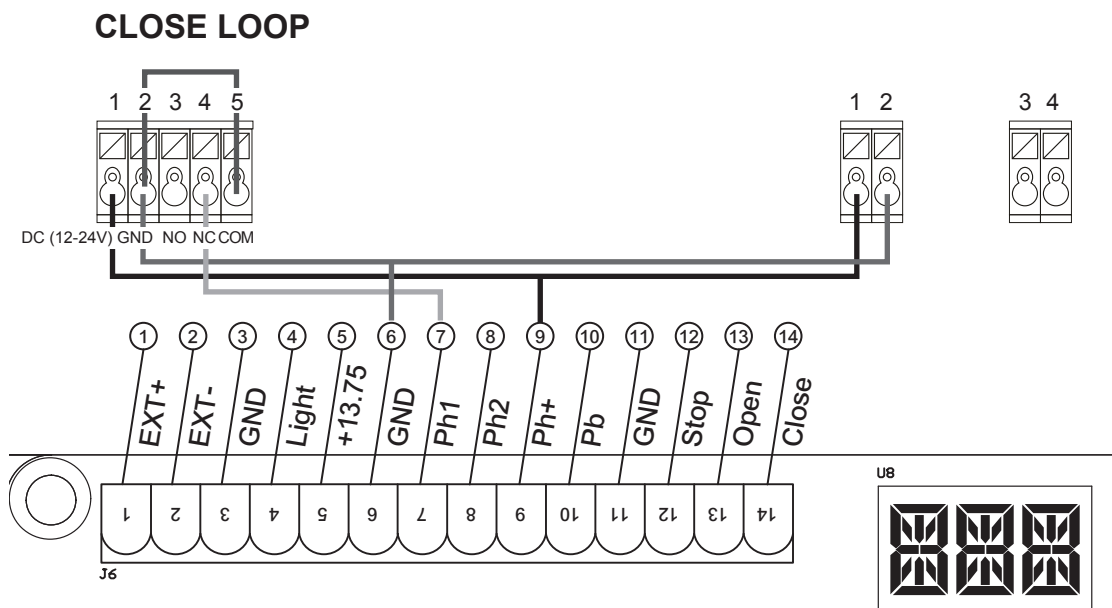
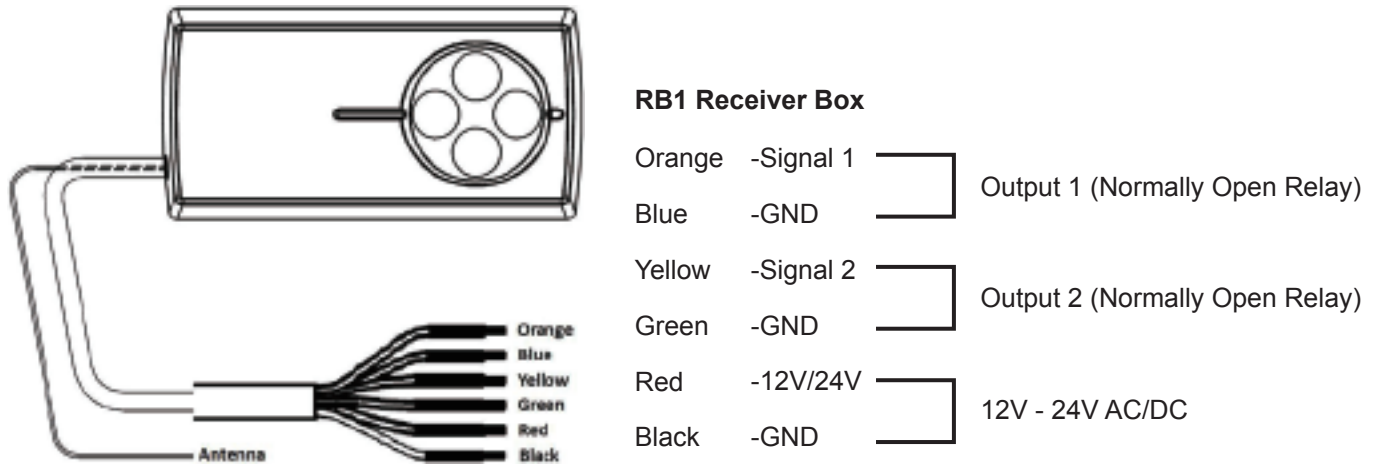

Figure 5(3)



5.2 WIRE CONNECTION AND SETTING OF RB1 EXTERNAL RECIEVER BOX



1. Situation:

In order to use one 4 channel remote to operate with additional device besides the original gate automation system. Install a receiver box to connect with the 2nd device (Such as swing/sliding gate opener) or the 3rd device (Such as garage automation system)

Original gate automation: Using Button A & B (Pedestrian Mode) on the remote to control gate opener

2nd device: Install an external receiver box, connect output 1 to the 2nd device (such as another Boxer Slider, shown as below) use button C on the same remote to control the 2nd device

3rd device: install an external receiver box, connect the output 2 to the 3rd device (such as garage door), use the Button D now to operate.

2. Wire Connection:

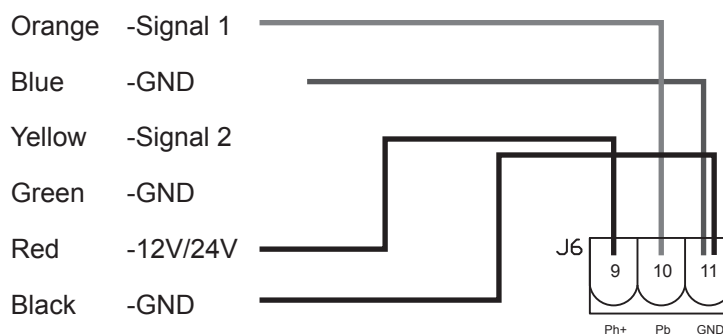

- Orange cable (Signal 1) connect to terminal 10 (Pb) on the control board
- Blue cable (GND) connect to terminal 11 (GND) on the control board
- Red cable (12V/24V ac/dc) connect to terminal 9 (Ph+) on the control board
- Black cable (GND) connect to terminal 11 (GND) on the control board

3. Device Testing & Remote Memorization

RB1 Receiver Box

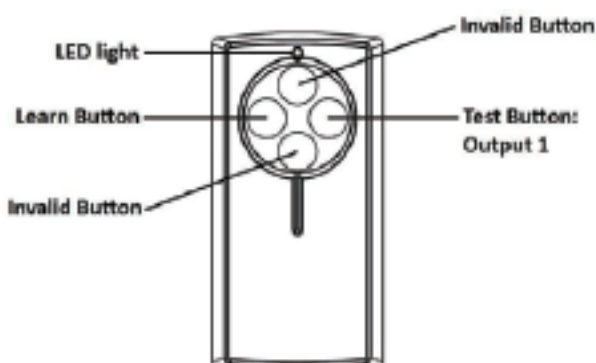

- After connect all necessary cables properly , press Test Button to exam if the output 1 is working, the gate opener should operate.
- If Output 1 is functional, press and hold Learn Button for 1 second, the LED light should be "ON"
* If the LED does not response, please check the cable connection again
- Press and hold Button C on the remote for 1 second after the LED is "ON". The remote completed the memorizing process when LED light turns "OFF"



24V power supply
for great safety



Solid material apply
with lasting usage



Manual release device
with easy use and
highly protection



Worm gear application
give silence operation



Easy installation
and user friendly
interface