

Keypad model 6612 and 7612

EasyGate has pre-programmed your keypad prior to sending with the PIN number 2580 or **2013**. The activation relay is set to **2** second so as to work with most gate openers. This also allows EasyGate to test the unit is working correctly prior to dispatch. You can easily remove this PIN from the system by following the “delete” guide of this manual once you have tested the keypads use. Follow all the installation guidelines fully. Failure may result in damage to the unit and void your warranty. We recommend a protective shroud in outdoor installations with high rain impact. See www.easygate.co.nz for more details. Note: 6612 model do not have the proximity reader.

Installation: The keypad requires 4 wires and can be installed in an outdoor setting using standard 12v Telecom direct burial electrical cable. The keypad is not suitable for hash salt spray environments.

Remove the screw at the bottom of the *backing plate* and **slide up** the front face of the keypad to unlock from the backing plate. The front face has been designed to allow small amounts moisture build-up to exit out the 2 drain holes in the bottom. Do not block these at any time. Keypad **MUST** be positioned vertical. Position the wire cable out of the wall that the keypad will be installed so that it will tread through the *backing plate*.

When installing the *backing plate* you **MUST** seal the back of the *backing plate* with a waterproof sealant to stop water entering the keypad. Place the sealant along the inside top and sides with the bottom left clear. Feed the wiring cable into the center square hole in the backing plate.

Position the *backing plate* (drain holes to the bottom) and secure with 2 x screws. Seal the wiring hole and cable to prevent insects and water entering the rear.

HINT: Never install wiring cable into the unit from a higher position then the exit point at the back plate as this may allow water to track along it and enter the main body.

The tiny screw can be lost if not careful while installing. Place a catch sheet on ground just in case! **Warranty:** 12 month “back to base” from time of purchase. See website for terms and conditions

Warning: Not suitable for hash salt environments.

Wiring instructions:

Only use 12 volt Direct Current (DC) power to this keypad via a fuse of 1 amp to prevent short circuit. On D1 and D2 control boards this is supplied already installed to the battery positive cable. If you are using other control boards then you will need to install the inline fuse to the battery lead or use 12v output terminal that is already fused. Check your control board manual. There are 4 wires to connect at both the keypad and your gate opener control board.

1. Connect wire 1 between +12V (POSITIVE) of the keypad to +12V (POSITIVE) of the gate opener control board
2. Connect wire 2 between -12V (GND) of the keypad to -12V (GND) of the gate opener control board (see note 1 below)
3. Connect wire 3 between COM of the keypad to COM of the gate opener control board that activates an OPEN cycle (see note 2 below)
4. Connect wire 4 between N/O of the keypad to N/O of the gate opener control board that activates an OPEN cycle

NOTE1: There is a white wire loop connected to GND and bell-1 on the keypad. You can connect the 12- negative from the control board to the Bell1 terminal of the other end of the loop on the keypad.

NOTE 2: On the keypad you will find the terminal block with the words “LOCK RELAY”. Connect COM and NO (normally open) from the keypad. This will activate an open cycle. You will need to identify on your gate opener control board a “start” terminal and a common terminal that will activate your gate opener. See your gate opener manual.

Programming your keypad: Before you can start to setup your keypad you must first understand the following terms; Remember the keypad is already pre programmed to test using PIN 2580 or **2013**

Program code: 4-digit master code (factory pre set 1234) allows access into the keypad's operating program system to add, change or delete codes. It can be changed at any time if required but remember to record the new Program Code on this manual.

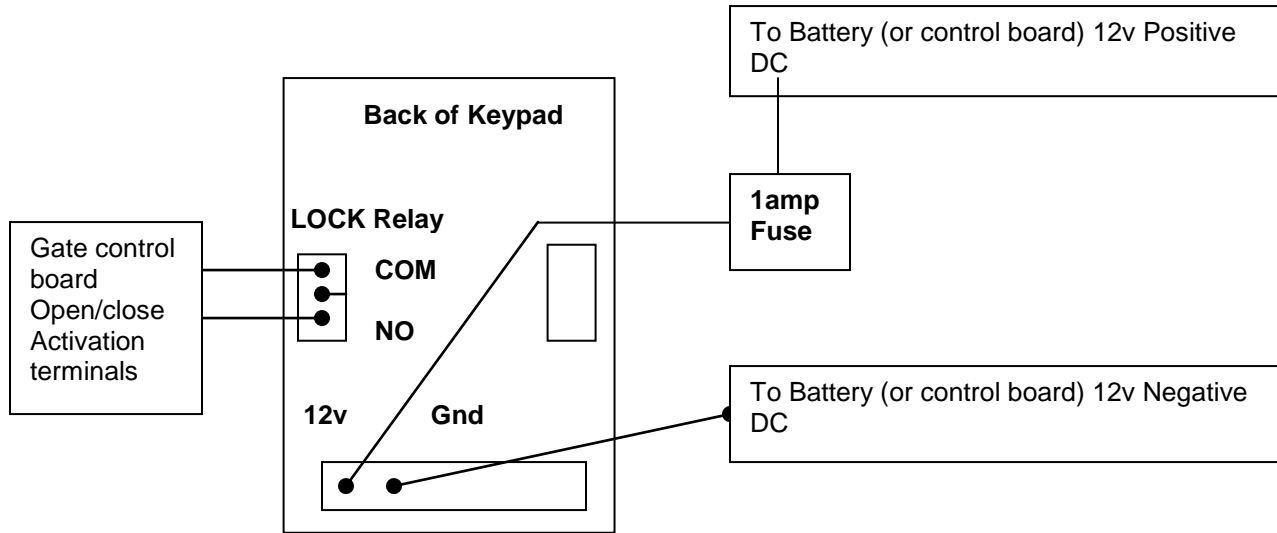

User code: Individual 3-digit number that must be allocated to every PIN code and Proximity card/tag. This will allow you to remove a PIN code without knowing the PIN code or having the proximity card/tag with you....lost proximity cards for example. You must remove a User Code first before changing its original allocated PIN Code.

Menu number: A single number that allocates a program type.

E.g. adding a new PIN Code is key 7 and deleting a PIN code is key 8.

PIN code: *Personal Identification Number* or 4-digit number that will be used by people who have been given the number to gain keypad access to activate the gate opener.

REX Button: Can be a Connection point for an exit button (N.O) to be placed inside the secured area. This means a PIN code is not required.

Hint: *The keypad can have 3 levels of operation Normal User, Secure User and Master User. We recommend you use the Normal User to simplify things!*

We recommend you first setup a simple Check Sheet to track User codes and PIN etc.

Example of a standard *Check Sheet* record as follows;

Step	Program a NEW 4 digit PIN code/card or tag to activate Keypad relay	Left LED	Right LED
1	Power up keypad to standby mode	Green	
2	Press # until the green LED changes to RED		Red
3	Quickly enter program code (1234)		Green
4	Enter Menu number 7		Red
5	Enter a 3-digit user code	Green flash	Red
6	Enter a 4-digit PIN code (or touch tag or card in the right/top corner of keypad)	Green	Red
7	Press # to exit to standby mode again	Green	
8	Test new PIN code	Green	Green

Step	Delete an OLD 4 digit user PIN code/card/tag	Left LED	Right LED
1	Power up keypad to standby mode	Green	
2	Press # until green LED changes to RED		Red
3	Quickly enter program code (1234)		Green
4	Enter Menu number 8	Red	Red
5	Enter a 3-digit user code	Red flash	Red

6	Enter program code (1234) again to confirm deletion	Green	Red
7	Press # to exit to standby mode again	Green	
8	Test deleted code is removed	Green	Red

Keypad Master setup									
Step 1	Power up keypad						Green	-----	
Step 2	Press # until green LED changes to RED						-----	Red	
Step 3	Enter current Program Code quickly (Factory default is 1234)						-----	Green	
Step 4	Decide on what action you want to do by pressing the following:								
	Change Open Code	Change Aux Code	Change Program Code	Change Secure Code	Change Open Delay Time	Enroll new PIN/ card/tag	Delete old PIN card/tag	Change back to factory setting	
	Menu 1	2	3	4	6	7	8	0 (B~)	
Step 5	Enter new 4 digit code				(A*)	Enter 3 digit User code	Enter 3 digit User code	Enter program code	
Step 6						Enter new PIN	Enter program code		
Step 7						Press # to exit setup	Press # to exit setup		

Switching Background Light ON or OFF

Background Light is off by default when new. Make sure the Mode Led is green before starting or it will not work.

- 1) Enter Programming Mode by pressing # until green light goes out (2-3 seconds)
- 2) Press 1234 quickly (programme code)
- 3) Press 6 to enter Menu 6
- 4) Press 2 to enter Auxiliary Control, Sub-Menu
- 5) Press 8 to enter Background Led Control Option
- 6) Press XX to Open/Close Background Led

XX: Close the Background Led for XX = 00. Open Background Led for XX = 01

Relay Output:

(A*) Change the time that the keypad stays active when a PIN is used.

The factory setting is 4 seconds which is ideal for magnetic locks but will be too long for gateopener control board activation. You can increase or decrease the time with a special 4 digit code formula.

There are 2 choices of *relay output* depending on the type of lock system you are connecting to the keypad outputs.

1. "Normally open" or short for NO = 00xx (used for most gate openers)
2. "Normally closed" or short for NC = 10xx (used for magnetic locks etc)

The first 2 digits are set depending on NO or NC but the remaining 2 digits (xx) represent the amount of seconds that you wish to use to keep the keypad active. E.g. If you want to have 2 second active keypad on a NO setup such as a gate opener, then the code would be 00 02.

Note: Almost all gate openers require a shorter active signal of 1-2 seconds:

Step	Change the open delay time that keypad stays active	Left LED	Right LED
1	Power up keypad to standby mode	Green	
2	Press hash until green LED changes to RED		Red
3	Quickly enter program code (1234)		Green
4	Enter Menu number 6		Red
5	Enter 0002 (if this does not work try 0001)		
6	Press hash to exit to standby mode again	Green	
7	Test by placing PIN to activate gateopener	Green	Green

(B-) Return to Factory Default Settings and delete all memory.

WARNING: All codes will return to the default factory settings and so erase the entire memory

NOTE: Make sure the Mode Led is green before starting or it will not work.

- 1) Enter Programming Mode (step 1 and 2)
- 2) Press 0 to enter Menu 0
- 3) Enter Programming Code to confirm

Replacing a lost Program Code

Note: The keypad must be in Normal Mode otherwise this will not work. Make sure that the Mode LED is green before proceeding.

- 1) Remove power
- 2) Press the REX Button
- 3) Apply power to the unit with REX Button pressed
- 4) Release the REX Button
- 5) You now have 15 seconds to program a new Program code into the unit using the initial default code 1-2-3-4, before the controller reverts to the existing code.

Replacing a lost Secure Code

Note: The keypad must be in Secure Mode otherwise this will not work. Make sure that the Mode LED is red before proceeding.

- 1) Remove power from the keypad
- 2) Press the REX Button
- 3) Apply power to the unit with REX button pressed
- 4) Release the REX Button
- 5) You now have 15 seconds to program a new secure code into the unit using the initial default code 3-8-3-8, before the controller reverts to the existing code.

Operations:

- 1)Enter Default Secure Number 3-8-3-8
- 2)Enter # to return to Normal Mode
- 3)Press # for 2 seconds
- 4)Enter Default Program Code 1-2-3-4
- 5)Press 4
- 6)Enter your new secure code

Bell: The connection for a bell will only activate an existing bell and will not power the bell.

For full manual please see product PDF at www.easygate.co.nz

Menu	Description of menu number	Factory setting	New Setting
1	Change open code	2580	
2	Change auxiliary code	0852	
3	Change program code	1234	
4	Change secure code	3838	
6	Change lock strike release time and tamper siren	0002 (2 sec)	
7	Enter new PIN number, define auxiliary input/out puts, enroll proximity cards/tags		
8	Delete PIN number		
9	Code assignment with strike/auxiliary		
0	Return to default factory settings		

Person given PIN code/card	3-digit User code (Between 001-499)	4-digit PIN Code
Factory test code	To change use menu 1	2580
	002	
	003	
	004	
	005	
Pre set sample test code	010	2013